

1974 INTERNATIONAL CONVENTION FOR THE SAFETY OF LIFE AT SEA

Adopted in London, United Kingdom on 1 November 1974

1974 INTERNATIONAL CONVENTION FOR THE SAFETY OF LIFE AT SEA	3
ARTICLE I GENERAL OBLIGATIONS UNDER THE CONVENTION	3
ARTICLE II APPLICATION.....	3
ARTICLE III LAWS, REGULATIONS.....	3
ARTICLE IV CASES OF <i>FORCE MAJEURE</i>	4
ARTICLE V CARRIAGE OF PERSONS IN EMERGENCY.....	4
ARTICLE VI PRIOR TREATIES AND CONVENTIONS.....	4
ARTICLE VII SPECIAL RULES DRAWN UP BY AGREEMENT	5
ARTICLE VIII AMENDMENTS.....	5
ARTICLE IX SIGNATURE, RATIFICATION, ACCEPTANCE, APPROVAL AND ACCESSION	7
ARTICLE X ENTRY INTO FORCE.....	7
ARTICLE XI DENUNCIATION.....	8
ARTICLE XII DEPOSIT AND REGISTRATION.....	8
ARTICLE XIII LANGUAGES.....	8
ANNEX	9
CHAPTER I GENERAL PROVISIONS.....	9
PART A APPLICATION, DEFINITIONS, ETC.....	9
PART B SURVEYS AND CERTIFICATES.....	11
PART C CASUALTIES	15
CHAPTER II-1 CONSTRUCTION SUBDIVISION AND STABILITY, MACHINERY AND ELECTRICAL INSTALLATIONS	16
PART A GENERAL.....	16
PART B SUBDIVISION AND STABILITY.....	18
PART C MACHINERY AND ELECTRICAL INSTALLATIONS.....	42
CHAPTER II-2 CONSTRUCTION - FIRE PROTECTION, FIRE DETECTION AND FIRE EXTINCTION	49
PART A GENERAL.....	49
PART B FIRE SAFETY MEASURES FOR PASSENGER SHIPS CARRYING MORE THAN 36 PASSENGERS	66
PART C FIRE SAFETY MEASURES FOR PASSENGER SHIPS CARRYING NOT MORE THAN 36 PASSENGERS.....	94
PART D FIRE SAFETY MEASURES FOR CARGO SHIPS	102
PART E FIRE SAFETY MEASURES FOR TANKERS	106
PART F SPECIAL FIRE SAFETY MEASURES FOR EXISTING PASSENGER SHIPS.....	114
CHAPTER III LIFE-SAVING APPLIANCES, ETC.	119
PART A GENERAL.....	120
PART B PASSENGER SHIPS ONLY.....	137

PART C CARGO SHIPS ONLY.....	143
CHAPTER IV RADIOTELEGRAPHY AND RADIOTELEPHONY	147
PART A APPLICATION AND DEFINITIONS	147
PART B WATCHES.....	148
PART C TECHNICAL REQUIREMENTS.....	150
PART D RADIO LOGS	161
CHAPTER V SAFETY OF NAVIGATION.....	163
CHAPTER VI CARRIAGE OF GRAIN.....	175
PART A GENERAL PROVISIONS.....	175
PART B CALCULATION OF ASSUMED HEELING MOMENTS	179
PART C GRAIN FITTINGS AND SECURING.....	187
CHAPTER VII CARRIAGE OF DANGEROUS GOODS	196
CHAPTER VIII NUCLEAR SHIPS	200

1974 INTERNATIONAL CONVENTION FOR THE SAFETY OF LIFE AT SEA

Adopted in London, United Kingdom on 1 November 1974

THE CONTRACTING GOVERNMENTS,

BEING DESIROUS of promoting safety of life at sea by establishing in common agreement uniform principles and rules directed thereto,

CONSIDERING that this end may best be achieved by the conclusion of a Convention to replace the International Convention for the Safety of Life at Sea, 1960, taking account of developments since that Convention was concluded,

HAVE AGREED as follows:

ARTICLE I GENERAL OBLIGATIONS UNDER THE CONVENTION

- (a) The Contracting Governments undertake to give effect to the provisions of the present Convention and the Annex thereto, which shall constitute an integral part of the present Convention. Every reference to the present Convention constitutes at the same time a reference to the Annex.
- (b) The Contracting Governments undertake to promulgate all laws, decrees, orders and regulations and to take all other steps which may be necessary to give the present Convention full and complete effect, so as to ensure that, from the point of view of safety of life, a ship is fit for the service for which it is intended.

ARTICLE II APPLICATION

The present Convention shall apply to ships entitled to fly the flag of States the Governments of which are Contracting Governments.

ARTICLE III LAWS, REGULATIONS

The Contracting Governments undertake to communicate to and deposit with the Secretary-General of the Inter-Governmental Maritime Consultative Organization (hereinafter referred to as "the Organization"):

- (a) a list of non-governmental agencies which are authorized to act in their behalf in the administration of measures for safety of life at sea for circulation to the Contracting Governments for the information of their officers;

- (b) the text of laws, decrees, orders and regulations which shall have been promulgated on the various matters within the scope of the present Convention;
- (c) a sufficient number of specimens of their Certificates issued under the provisions of the present Convention for circulation to the Contracting Governments for the information of their officers.

ARTICLE IV

CASES OF *FORCE MAJEURE*

- (a) A ship, which is not subject to the provisions of the present Convention at the time of its departure on any voyage, shall not become subject to the provisions of the present Convention on account of any deviation from its intended voyage due to stress of weather or any other cause of *force majeure*.
- (b) Persons who are on board a ship by reason of *force majeure* or in consequence of the obligation laid upon the master to carry shipwrecked or other persons shall not be taken into account for the purpose of ascertaining the application to a ship of any provisions of the present Convention.

ARTICLE V

CARRIAGE OF PERSONS IN EMERGENCY

- (a) For the purpose of evacuating persons in order to avoid a threat to the security of their lives a Contracting Government may permit the carriage of a larger number of persons in its ships than is otherwise permissible under the present Convention.
- (b) Such permission shall not deprive other Contracting Governments of any right of control under the present Convention over such ships which come within their ports.
- (c) Notice of any such permission, together with a statement of the circumstances, shall be sent to the Secretary-General of the Organization by the Contracting Government granting such permission.

ARTICLE VI

PRIOR TREATIES AND CONVENTIONS

- (a) As between the Contracting Governments, the present Convention replaces and abrogates the International Convention for the Safety of Life at Sea which was signed in London on 17 June 1960.
- (b) All other treaties, conventions and arrangements relating to safety of life at sea, or matters appertaining thereto, at present in force between Governments parties to the present Convention shall continue to have full and complete effect during the terms thereof as regards:
 - (i) ships to which the present Convention does not apply;
 - (ii) ships to which the present Convention applies, in respect of matters for which it has not expressly provided.
- (c) To the extent, however, that such treaties, conventions or arrangements conflict with the provisions of the present Convention, the provisions of the present Convention shall prevail.

- (d) All matters which are not expressly provided for in the present Convention remain subject to the legislation of the Contracting Governments.

ARTICLE VII

SPECIAL RULES DRAWN UP BY AGREEMENT

When in accordance with the present Convention special rules are drawn up by agreement between all or some of the Contracting Governments, such rules shall be communicated to the Secretary-General of the Organization for circulation to all Contracting Governments.

ARTICLE VIII

AMENDMENTS

- (a) The present Convention may be amended by either of the procedures specified in the following paragraphs.
- (b) Amendments after consideration within the Organization:
- (i) Any amendment proposed by a Contracting Government shall be submitted to the Secretary-General of the Organization, who shall then circulate it to all Members of the Organization and all Contracting Governments at least six months prior to its consideration.
 - (ii) Any amendment proposed and circulated as above shall be referred to the Maritime Safety Committee of the Organization for consideration.
 - (iii) Contracting Governments of States, whether or not Members of the Organization, shall be entitled to participate in the proceedings of the Maritime Safety Committee for the consideration and adoption of amendments.
 - (iv) Amendments shall be adopted by a two-thirds majority of the Contracting Governments present and voting in the Maritime Safety Committee expanded as provided for in sub-paragraph (iii) of this paragraph (hereinafter referred to as "the expanded Maritime Safety Committee") on condition that at least one-third of the Contracting Governments shall be present at the time of voting.
 - (v) Amendments adopted in accordance with sub-paragraph (iv) of this paragraph shall be communicated by the Secretary-General of the Organization to all Contracting Governments for acceptance.
 - (vi) (1) An amendment to an Article of the Convention or to Chapter I of the Annex shall be deemed to have been accepted on the date on which it is accepted by two-thirds of the Contracting Governments.
 - (2) An amendment to the Annex other than Chapter I shall be deemed to have been accepted:
 - (aa) at the end of two years from the date on which it is communicated to Contracting Governments for acceptance; or
 - (bb) at the end of a different period, which shall not be less than one year, if so determined at the time of its adoption by a two-thirds majority of the Contracting Governments present and voting in the expanded Maritime Safety Committee.

However, if within the specified period either more than one-third of Contracting Governments, or Contracting Governments the combined merchant fleets of which constitute not less than fifty per cent of the gross tonnage of the world's merchant fleet, notify the Secretary-General of the Organization that they object to the amendment, it shall be deemed not to have been accepted.

(vii) (1) An amendment to an Article of the Convention or to Chapter I of the Annex shall enter into force with respect to those Contracting Governments which have accepted it, six months after the date on which it is deemed to have been accepted, and with respect to each Contracting Government which accepts it after that date, six months after the date of that Contracting Government's acceptance.

(2) An amendment to the Annex other than Chapter I shall enter into force with respect to all Contracting Governments, except those which have objected to the amendment under sub-paragraph (vi)(2) of this paragraph and which have not withdrawn such objections, six months after the date on which it is deemed to have been accepted. However, before the date set for entry into force, any Contracting Government may give notice to the Secretary-General of the Organization that it exempts itself from giving effect to that amendment for a period not longer than one year from the date of its entry into force, or for such longer period as may be determined by a two-thirds majority of the Contracting Governments present and voting in the expanded Maritime Safety Committee at the time of the adoption of the amendment.

(c) Amendment by a Conference:

(i) Upon the request of a Contracting Government concurred in by at least one-third of the Contracting Governments, the Organization shall convene a Conference of Contracting Governments to consider amendments to the present Convention.

(ii) Every amendment adopted by such a Conference by a two-thirds majority of the Contracting Governments present and voting shall be communicated by the Secretary-General of the Organization to all Contracting Governments for acceptance.

(iii) Unless the Conference decides otherwise, the amendment shall be deemed to have been accepted and shall enter into force in accordance with the procedures specified in sub-paragraphs (b)(vi) and (b)(vii) respectively of this Article, provided that references in these paragraphs to the expanded Maritime Safety Committee shall be taken to mean references to the Conference.

(d) (i) A Contracting Government which has accepted an amendment to the Annex which has entered into force shall not be obliged to extend the benefit of the present Convention in respect of the certificates issued to a ship entitled to fly the flag of a State the Government of which, pursuant to the provisions of sub-paragraph (b)(vi)(2) of this Article, has objected to the amendment and has not withdrawn such an objection, but only to the extent that such certificates relate to matters covered by the amendment in question.

(ii) A Contracting Government which has accepted an amendment to the Annex which has entered into force shall extend the benefit of the present Convention in respect of the certificates issued to a ship entitled to fly the flag of a State the Government of which, pursuant to the provisions of sub-paragraph (b)(vii)(2) of this Article, has notified the Secretary-General of the Organization that it exempts itself from giving effect to the amendment.

- (e) Unless expressly provided otherwise, any amendment to the present Convention made under this Article, which relates to the structure of a ship, shall apply only to ships the keels of which are laid or which are at a similar stage of construction, on or after the date on which the amendment enters into force.
- (f) Any declaration of acceptance of, or objection to, an amendment or any notice given under subparagraph (b)(vii)(2) of this Article shall be submitted in writing to the Secretary-General of the Organization, who shall inform all Contracting Governments of any such submission and the date of its receipt.
- (g) The Secretary-General of the Organization shall inform all Contracting Governments of any amendments which enter into force under this Article, together with the date on which each such amendment enters into force.

ARTICLE IX

SIGNATURE, RATIFICATION, ACCEPTANCE, APPROVAL AND ACCESSION

- (a) The present Convention shall remain open for signature at the Headquarters of the Organization from 1 November 1974 until 1 July 1975 and shall thereafter remain open for accession. States may become parties to the present Convention by:
 - (i) signature without reservation as to ratification, acceptance or approval; or
 - (ii) signature subject to ratification, acceptance or approval, followed by ratification, acceptance or approval; or
 - (iii) accession.
- (b) Ratification, acceptance, approval or accession shall be effected by the deposit of an instrument to that effect with the Secretary-General of the Organization.
- (c) The Secretary-General of the Organization shall inform the Governments of all States which have signed the present Convention or acceded to it of any signature or of the deposit of any instrument of ratification, acceptance, approval or accession and the date of its deposit.

ARTICLE X

ENTRY INTO FORCE

- (a) The present Convention shall enter into force twelve months after the date on which not less than twenty-five States, the combined merchant fleets of which constitute not less than fifty per cent of the gross tonnage of the world's merchant shipping, have become parties to it in accordance with Article IX.
- (b) Any instrument of ratification, acceptance, approval or accession deposited after the date on which the present Convention enters into force shall take effect three months after the date of deposit.
- (c) After the date on which an amendment to the present Convention is deemed to have been accepted under Article VIII, any instrument of ratification, acceptance, approval or accession deposited shall apply to the Convention as amended.

ARTICLE XI DENUNCIATION

- (a) The present Convention may be denounced by any Contracting Government at any time after the expiry of five years from the date on which the Convention enters into force for that Government.
- (b) Denunciation shall be effected by the deposit of an instrument of denunciation with the Secretary-General of the Organization who shall notify all the other Contracting Governments of any instrument of denunciation received and of the date of its receipt as well as the date on which such denunciation takes effect.
- (c) A denunciation shall take effect one year, or such longer period as may be specified in the instrument of denunciation, after its receipt by the Secretary-General of the Organization.

ARTICLE XII DEPOSIT AND REGISTRATION

- (a) The present Convention shall be deposited with the Secretary-General of the Organization who shall transmit certified true copies thereof to the Governments of all States which have signed the present Convention or acceded to it.
- (b) As soon as the present Convention enters into force, the text shall be transmitted by the Secretary-General of the Organization to the Secretary-General of the United Nations for registration and publication, in accordance with Article 102 of the Charter of the United Nations.

ARTICLE XIII LANGUAGES

The present Convention is established in a single copy in the Chinese, English, French, Russian and Spanish languages, each text being equally authentic. Official translations in the Arabic, German and Italian languages shall be prepared and deposited with the signed original.

IN WITNESS WHEREOF the undersigned, being duly authorized by their respective Governments for that purpose, have signed the present Convention.

DONE at London this first day of November one thousand nine hundred and seventy-four.

[Signatures not reproduced here.]

ANNEX

CHAPTER I

GENERAL PROVISIONS

PART A

APPLICATION, DEFINITIONS, ETC.

Regulation 1. Application

- (a) Unless expressly provided otherwise, the present Regulations apply only to ships engaged on international voyages.
- (b) The classes of ships to which each Chapter applies are more precisely defined, and the extent of the application is shown, in each Chapter.

Regulation 2. Definitions

For the purpose of the present Regulations, unless expressly provided otherwise:

- (a) "Regulations" means the Regulations contained in the Annex to the present Convention.
- (b) "Administration" means the Government of the State whose flag the ship is entitled to fly.
- (c) "Approved" means approved by the Administration.
- (d) "International voyage" means a voyage from a country to which the present Convention applies to a port outside such country, or conversely.
- (e) A passenger is every person other than:
 - (i) the master and the members of the crew or other persons employed or engaged in any capacity on board a ship on the business of that ship; and
 - (ii) a child under one year of age.
- (f) A passenger ship is a ship which carries more than twelve passengers.
- (g) A cargo ship is any ship which is not a passenger ship.
- (h) A tanker is a cargo ship constructed or adapted for the carriage in bulk of liquid cargoes of an inflammable¹ nature.
- (i) A fishing vessel is a vessel used for catching fish, whales, seals, walrus or other living resources of the sea.
- (j) A nuclear ship is a ship provided with a nuclear power plant.
- (k) "New ship" means a ship the keel of which is laid or which is at a similar stage of construction on or after the date of coming into force of the present Convention.

¹ "Inflammable" has the same meaning as "flammable".

(l) "Existing ship" means a ship which is not a new ship.

(m) A mile is 1,852 metres or 6,080 feet.

Regulation 3. Exceptions

(a) The present Regulations, unless expressly provided otherwise, do not apply to:

- (i) Ships of war and troopships.
- (ii) Cargo ships of less than 500 tons gross tonnage.
- (iii) Ships not propelled by mechanical means.
- (iv) Wooden ships of primitive build.
- (v) Pleasure yachts not engaged in trade.
- (vi) Fishing vessels

(b) Except as expressly provided in Chapter V, nothing herein shall apply to ships solely navigating the Great Lakes of North America and the River St. Lawrence as far east as a straight line drawn from Cap des Rosiers to West Point, Anticosti Island and, on the north side of Anticosti Island, the 63rd Meridian.

Regulation 4. Exemptions

(a) A ship which is not normally engaged on international voyages but which, in exceptional circumstances, is required to undertake a single international voyage may be exempted by the Administration from any of the requirements of the present Regulations provided that it complies with safety requirements which are adequate in the opinion of the Administration for the voyage which is to be undertaken by the ship.

(b) The Administration may exempt any ship which embodies features of a novel kind from any of the provisions of Chapters II-1, II-2, III and IV of these Regulations the application of which might seriously impede research into the development of such features and their incorporation in ships engaged on international voyages. Any such ship shall, however, comply with safety requirements which, in the opinion of that Administration, are adequate for the service for which it is intended and are such as to ensure the overall safety of the ship and which are acceptable to the Governments of the States to be visited by the ship. The Administration which allows any such exemption shall communicate to the Organization particulars of same and the reasons therefor which the Organization shall circulate to the Contracting Governments for their information.

Regulation 5. Equivalents

(a) Where the present Regulations require that a particular fitting, material, appliance or apparatus, or type thereof, shall be fitted or carried in a ship, or that any particular provision shall be made, the Administration may allow any other fitting, material, appliance or apparatus, or type thereof, to be fitted or carried, or any other provision to be made in that ship, if it is satisfied by trial thereof or otherwise that such fitting, material, appliance or apparatus, or type thereof, or provision, is at least as effective as that required by the present Regulations.

- (b) Any Administration which so allows, in substitution, a fitting, material, appliance or apparatus, or type thereof, or provision, shall communicate to the Organization particulars thereof together with a report on any trials made and the Organization shall circulate such particulars to other Contracting Governments for the information of their officers.

PART B SURVEYS AND CERTIFICATES

Regulation 6. Inspection and Survey

The inspection and survey of ships, so far as regards the enforcement of the provisions of the present Regulations and the granting of exemptions therefrom, shall be carried out by officers of the State whose flag the ship is entitled to fly, provided that the Government of each State may entrust the inspection and survey either to surveyors nominated for the purpose or to organizations recognized by it. In every case the Government concerned fully guarantees the completeness and efficiency of the inspection and survey.

Regulation 7. Surveys of Passenger Ships

- (a) A passenger ship shall be subjected to the surveys specified below:
- (i) A survey before the ship is put in service.
 - (ii) A periodical survey once every twelve months.
 - (iii) Additional surveys, as occasion arises.
- (b) The surveys referred to above shall be carried out as follows:
- (i) The survey before the ship is put in service shall include a complete inspection of its structure, machinery and equipment, including the outside of the ship's bottom and the inside and outside of the boilers. This survey shall be such as to ensure that the arrangements, material, and scantlings of the structure, boilers and other pressure vessels and their appurtenances, main and auxiliary machinery, electrical installation, radio installation, radiotelegraph installations in motor lifeboats, portable radio apparatus for survival craft, life-saving appliances, fire protection, fire detecting and extinguishing appliances, radar, echo-sounding device, gyro-compass, pilot ladders, mechanical pilot hoists and other equipment, fully comply with the requirements of the present Convention, and of the laws, decrees, orders and regulations promulgated as a result thereof by the Administration for ships of the service for which it is intended. The survey shall also be such as to ensure that the workmanship of all parts of the ship and its equipment is in all respects satisfactory, and that the ship is provided with the lights, shapes, means of making sound signals and distress signals as required by the provisions of the present Convention and the International Regulations for Preventing Collisions at Sea in force.
 - (ii) The periodical survey shall include an inspection of the structure, boilers and other pressure vessels, machinery and equipment, including the outside of the ship's bottom. The survey shall be such as to ensure that the ship, as regards the structure, boilers and other pressure vessels and their appurtenances, main and auxiliary machinery, electrical installation, radio installation, radiotelegraph installations in motor lifeboats, portable radio apparatus for survival craft, life-saving appliances, fire protection, fire detection and extinguishing appliances, radar, echo-sounding device, gyro-compass, pilot ladders, mechanical pilot hoists and other equipment, is in satisfactory condition and fit for the service for which it is

intended, and that it complies with the requirements of the present Convention, and of the laws, decrees, orders and regulations promulgated as a result thereof by the Administration. The lights, shapes and means of making sound signals and the distress signals carried by the ship shall also be subject to the above-mentioned survey for the purpose of ensuring that they comply with the requirements of the present Convention and of the International Regulations for Preventing Collisions at Sea in force.

- (iii) A survey either general or partial, according to the circumstances, shall be made every time an accident occurs or a defect is discovered which affects the safety of the ship or the efficiency or completeness of its life-saving appliances or other equipment, or whenever any important repairs or renewals are made. The survey shall be such as to ensure that the necessary repairs or renewals have been effectively made, that the material and workmanship of such repairs or renewals are in all respects satisfactory, and that the ship complies in all respects with the provisions of the present Convention and of the International Regulations for Preventing Collisions at Sea in force, and of the laws, decrees, orders and regulations promulgated as a result thereof by the Administration.
- (c) (i) The laws, decrees, orders and regulations referred to in paragraph (b) of this Regulation shall be in all respects such as to ensure that, from the point of view of safety of life, the ship is fit for the service for which it is intended.
- (ii) They shall among other things prescribe the requirements to be observed as to the initial and subsequent hydraulic or other acceptable alternative tests to which the main and auxiliary boilers, connexions, steam pipes, high pressure receivers, and fuel tanks for internal combustion engines are to be submitted including the test procedures to be followed and the intervals between two consecutive tests.

Regulation 8. Surveys of Life-saving Appliances and Other Equipment of Cargo Ships

The life-saving appliances, except a radiotelegraph installation in a motor lifeboat or a portable radio apparatus for survival craft, the echo-sounding device, the gyro-compass, and the fire-extinguishing appliances of cargo ships to which Chapters II-1, II-2, III and V apply shall be subject to initial and subsequent surveys as provided for passenger ships in Regulation 7 of this Chapter with the substitution of 24 months for 12 months in sub-paragraph (a)(ii) of that Regulation. The fire control plans in new ships and the pilot ladders, mechanical pilot hoists, lights, shapes and means of making sound signals carried by new and existing ships shall be included in the surveys for the purpose of ensuring that they comply fully with the requirements of the present Convention and, where applicable, the International Regulations for Preventing Collisions at Sea in force.

Regulation 9. Surveys of Radio and Radar Installations of Cargo Ships

The radio and radar installations of cargo ships to which Chapters IV and V apply and any radiotelegraph installation in a motor lifeboat or portable radio apparatus for survival craft which is carried in compliance with the requirements of Chapter III shall be subject to initial and subsequent surveys as provided for passenger ships in Regulation 7 of this Chapter.

Regulation 10. Surveys of Hull, Machinery and Equipment of Cargo Ships

The hull, machinery and equipment (other than items in respect of which Cargo Ship Safety Equipment Certificates, Cargo Ship Safety Radiotelegraphy Certificates or Cargo Ship Safety Radiotelephony Certificates are issued) of a cargo ship shall be surveyed on completion and thereafter in such manner and at such intervals as the Administration may consider necessary in order to ensure that their condition is in all respects satisfactory. The survey shall be such as to ensure that the arrangements,

material, and scantlings of the structure, boilers and other pressure vessels and their appurtenances, main and auxiliary machinery, electrical installations and other equipment are in all respects satisfactory for the service for which the ship is intended.

Regulation 11. Maintenance of Conditions After Survey

After any survey of the ship under Regulations 7, 8, 9 or 10 of this Chapter has been completed, no change shall be made in the structural arrangements, machinery, equipment, etc. covered by the survey, without the sanction of the Administration.

Regulation 12. Issue of Certificates

- (a) (i) A certificate called a Passenger Ship Safety Certificate shall be issued after inspection and survey to a passenger ship which complies with the requirements of Chapters II-1, II-2, III and IV and any other relevant requirements of the present Regulations.
 - (ii) A certificate called a Cargo Ship Safety Construction Certificate shall be issued after survey to a cargo ship which satisfies the requirements for cargo ships on survey set out in Regulation 10 of this Chapter and complies with the applicable requirements of Chapters II-1 and II-2 other than those relating to fire-extinguishing appliances and fire control plans.
 - (iii) A certificate called a Cargo Ship Safety Equipment Certificate shall be issued after inspection to a cargo ship which complies with the relevant requirements of Chapters II-1, II-2 and III and any other relevant requirements of the present Regulations.
 - (iv) A certificate called a Cargo Ship Safety Radiotelegraphy Certificate shall be issued after inspection to a cargo ship, fitted with a radio-telegraph installation, which complies with the requirements of Chapter IV and any other relevant requirements of the present Regulations.
 - (v) A certificate called a Cargo Ship Safety Radiotelephony Certificate shall be issued after inspection to a cargo ship, fitted with a radio-telephone installation, which complies with the requirements of Chapter IV and any other relevant requirements of the present Regulations.
 - (vi) When an exemption is granted to a ship under and in accordance with the provisions of the present Regulations, a certificate called an Exemption Certificate shall be issued in addition to the certificates prescribed in this paragraph.
 - (vii) Passenger Ship Safety Certificates, Cargo Ship Safety Construction Certificates, Cargo Ship Safety Equipment Certificates, Cargo Ship Safety Radiotelegraphy Certificates, Cargo Ship Safety Radiotelephony Certificates and Exemption Certificates shall be issued either by the Administration or by any person or organization duly authorized by it. In every case, that Administration assumes full responsibility for the Certificate.
- (b) Notwithstanding any other provision of the present Convention any certificate issued under, and in accordance with, the provisions of the International Convention for the Safety of Life at Sea, 1960, which is current when the present Convention comes into force in respect of the Administration by which the certificate is issued, shall remain valid until it expires under the terms of Regulation 14 of Chapter I of that Convention.
- (c) A Contracting Government shall not issue certificates under, and in accordance with, the provisions of the International Convention for the Safety of Life at Sea, 1960, 1948 or 1929, after the date on which acceptance of the present Convention by the Government takes effect.

Regulation 13. Issue of Certificate by Another Government

A Contracting Government may, at the request of the Administration, cause a ship to be surveyed and, if satisfied that the requirements of the present Regulations are complied with, shall issue certificates to the ship in accordance with the present Regulations. Any certificate so issued must contain a statement to the effect that it has been issued at the request of the Government of the State whose flag the ship is or will be entitled to fly, and it shall have the same force and receive the same recognition as a certificate issued under Regulation 12 of this Chapter.

Regulation 14. Duration of Certificates

- (a) Certificates other than Cargo Ship Safety Construction Certificates, Cargo Ship Safety Equipment Certificates and Exemption Certificates shall be issued for a period of not more than 12 months. Cargo Ship Safety Equipment Certificates shall be issued for a period of not more than 24 months. Exemption Certificates shall not be valid for longer than the period of the certificates to which they refer.
- (b) If a survey takes place within two months before the end of the period for which a Cargo Ship Safety Radiotelegraphy Certificate or a Cargo Ship Safety Radiotelephony Certificate issued in respect of cargo ships of 300 tons gross tonnage and upwards, but less than 500 tons gross tonnage, was originally issued, that certificate may be withdrawn, and a new certificate may be issued which shall expire 12 months after the end of the said period.
- (c) If a ship at the time when its certificate expires is not in a port of the State whose flag it is entitled to fly, the certificate may be extended by the Administration, but such extension shall be granted only for the purpose of allowing the ship to complete its voyage to the State whose flag it is entitled to fly or in which it is to be surveyed, and then only in cases where it appears proper and reasonable so to do.
- (d) No certificate shall be thus extended for a longer period than five months, and a ship to which such extension is granted shall not, on its arrival in the State whose flag it is entitled to fly or the port in which it is to be surveyed, be entitled by virtue of such extension to leave that port or State without having obtained a new certificate.
- (e) A certificate which has not been extended under the foregoing provisions of this Regulation may be extended by the Administration for a period of grace of up to one month from the date of expiry stated on it.

Regulation 15. Form of Certificates

- (a) All certificates shall be drawn up in the official language or languages of the country by which they are issued.
- (b) The form of the certificates shall be that of the models given in the Appendix to the present Regulations. The arrangement of the printed part of the model certificates shall be exactly reproduced in the certificates issued, or in certified copies thereof, and the particulars inserted in the certificates issued, or in certified copies thereof, shall be in Roman characters and Arabic figures.

Regulation 16. Posting Up of Certificates

All certificates or certified copies thereof issued under the present Regulations shall be posted up in a prominent and accessible place in the ship.

Regulation 17. Acceptance of Certificates

Certificates issued under the authority of a Contracting Government shall be accepted by the other Contracting Governments for all purposes covered by the present Convention. They shall be regarded by the other Contracting Governments as having the same force as certificates issued by them.

Regulation 18. Qualification of Certificates

- (a) If in the course of a particular voyage a ship has on board a number of persons less than the total number stated in the Passenger Ship Safety Certificate and is in consequence, in accordance with the provisions of the present Regulations, free to carry a small number of lifeboats and other life-saving appliances than that stated in the Certificate, an annex may be issued by the Government, person or organization referred to in Regulation 12 or 13 of this Chapter.
- (b) This annex shall state that in the circumstances there is no infringement of the provisions of the present Regulations. It shall be annexed to the Certificate and shall be substituted for it in so far as the life-saving appliances are concerned. It shall be valid only for the particular voyage for which it is issued.

Regulation 19. Control

Every ship holding a certificate issued under Regulation 12 or Regulation 13 of this Chapter is subject in the ports of the other Contracting Governments to control by officers duly authorized by such Governments in so far as this control is directed towards verifying that there is on board a valid certificate. Such certificate shall be accepted unless there are clear grounds for believing that the condition of the ship or of its equipment does not correspond substantially with the particulars of that certificate. In that case, the officer carrying out the control shall take such steps as will ensure that the ship shall not sail until it can proceed to sea without danger to the passengers or the crew. In the event of this control giving rise to intervention of any kind, the officer carrying out the control shall inform the Consul of the State whose flag the ship is entitled to fly in writing forthwith of all the circumstances in which intervention was deemed to be necessary, and the facts shall be reported to the Organization.

Regulation 20. Privileges

The privileges of the present Convention may not be claimed in favour of any ship unless it holds appropriate valid certificates.

PART C CASUALTIES

Regulation 21. Casualties

- (a) Each Administration undertakes to conduct an investigation of any casualty occurring to any of its ships subject to the provisions of the present Convention when it judges that such an investigation may assist in determining what changes in the present Regulations might be desirable.
- (b) Each Contracting Government undertakes to supply the Organization with pertinent information concerning the findings of such investigations. No reports or recommendations of the Organization based upon such information shall disclose the identity or nationality of the ships concerned or in any manner fix or imply responsibility upon any ship or person.

CHAPTER II-1

CONSTRUCTION SUBDIVISION AND STABILITY, MACHINERY AND ELECTRICAL INSTALLATIONS

PART A GENERAL

Regulation 1. Application

- (a) (i) Unless expressly provided otherwise, this Chapter applies to new ships.
- (ii) Existing passenger ships and cargo ships shall comply with the following:
- (1) for ships the keels of which were laid or which were at a similar stage of construction on or after the date of coming into force of the International Convention for the Safety of Life at Sea, 1960, the Administration shall ensure that the requirements which were applied under Chapter II of that Convention to new ships as defined in that Chapter are complied with;
 - (2) for ships the keels of which were laid or which were at a similar stage of construction on or after the date of coming into force of the International Convention for the Safety of Life at Sea, 1948, but before the date of coming into force of the International Convention for the Safety of Life at Sea, 1960, the Administration shall ensure that the requirements which were applied under Chapter II of the 1948 Convention to new ships as defined in that Chapter are complied with;
 - (3) for ships the keels of which were laid or which were at a similar stage of construction before the date of coming into force of the International Convention for the Safety of Life at Sea, 1948, the Administration shall ensure that the requirements which were applied under Chapter II of that Convention to existing ships as defined in that Chapter are complied with;
 - (4) as regards the requirements of Chapter II-1 of the present Convention which are not contained in Chapter II of the 1960 and 1948 Conventions, the Administration shall decide which of these requirements shall be applied to existing ships as defined in the present Convention.
- (iii) A ship which undergoes repairs, alterations, modifications and outfitting related thereto shall continue to comply with at least the requirements previously applicable to the ship. An existing ship in such a case shall not, as a rule, comply to a lesser extent with the requirements for a new ship than it did before. Repairs, alterations and modifications of a major character and outfitting related thereto should meet the requirements for a new ship in so far as the Administration deems reasonable and practicable.
- (b) For the purpose of this Chapter:
- (i) A new passenger ship is a passenger ship the keel of which is laid or which is at a similar stage of construction on or after the date of coming into force of the present Convention, or a cargo ship which is converted to a passenger ship on or after that date, all other passenger ships being described as existing passenger ships.

- (ii) A new cargo ship is a cargo ship the keel of which is laid or which is at a similar stage of construction on or after the date of coming into force of the present Convention.
- (c) The Administration may, if it considers that the sheltered nature and conditions of the voyage are such as to render the application of any specific requirements of this Chapter unreasonable or unnecessary, exempt from those requirements individual ships or classes of ships belonging to its country which, in the course of their voyage, do not proceed more than 20 miles from the nearest land.
- (d) In the case of a passenger ship which is permitted under paragraph (c) of Regulation 27 of Chapter III to carry a number of persons on board in excess of the lifeboat capacity provided, it shall comply with the special standards of subdivision set out in paragraph (e) of Regulation 5 of this Chapter, and the associated special provisions regarding permeability in paragraph (d) of Regulation 4 of this Chapter, unless the Administration is satisfied that, having regard to the nature and conditions of the voyage, compliance with the other provisions of the Regulations of this Chapter and Chapter II-2 of the present Convention is sufficient.
- (e) In the case of passenger ships which are employed in special trades for the carriage of large numbers of special trade passengers, such as the pilgrim trade, the Administration, if satisfied that it is impracticable to enforce compliance with the requirements of this Chapter, may exempt such ships, when they belong to its country, from those requirements, provided that they comply fully with the provisions of:
 - (i) the Rules annexed to the Special Trade Passenger Ships Agreement, 1971, and
 - (ii) the Rules annexed to the Protocol on Space Requirements for Special Trade Passenger Ships, 1973, when it enters into force.

Regulation 2. Definitions

For the purpose of this Chapter, unless expressly provided otherwise:

- (a) (i) A subdivision load line is a water-line used in determining the subdivision of the ship.
 - (ii) The deepest subdivision load line is the water-line which corresponds to the greatest draught permitted by the subdivision requirements which are applicable.
- (b) The length of the ship is the length measured between perpendiculars taken at the extremities of the deepest subdivision load line.
- (c) The breadth of the ship is the extreme width from outside of frame to outside of frame at or below the deepest subdivision load line.
- (d) The draught is the vertical distance from the moulded base line amidships to the subdivision load line in question.
- (e) The bulkhead deck is the uppermost deck up to which the transverse watertight bulkheads are carried.
- (f) The margin line is a line drawn at least 76 millimetres (3 inches) below the upper surface of the bulkhead deck at side.
- (g) The permeability of a space is the percentage of that space which can be occupied by water.

The volume of a space which extends above the margin line shall be measured only to the height of that line.

- (h) The machinery space is to be taken as extending from the moulded base line to the margin line and between the extreme main transverse watertight bulkheads bounding the spaces containing the main and auxiliary propelling machinery, boilers serving the needs of propulsion, and all permanent coal bunkers.

In the case of unusual arrangements, the Administration may define the limits of the machinery spaces.

- (i) Passenger spaces are those which are provided for the accommodation and use of passengers, excluding baggage, store, provision and mail rooms.

For the purposes of Regulations 4 and 5 of this Chapter, spaces provided below the margin line for the accommodation and use of the crew shall be regarded as passenger spaces.

- (j) In all cases volumes and areas shall be calculated to moulded lines.

PART B SUBDIVISION AND STABILITY²

(Part B applies to passenger ships only, except that Regulation 19 also applies to cargo ships.)

Regulation 3. Floodable Length

- (a) The floodable length at any point of the length of a ship shall be determined by a method of calculation which takes into consideration the form, draught and other characteristics of the ship in question.
- (b) In a ship with a continuous bulkhead deck, the floodable length at a given point is the maximum portion of the length of the ship, having its centre at the point in question, which can be flooded under the definite assumptions set forth in Regulation 4 of this Chapter without the ship being submerged beyond the margin line.
- (c) (i) In the case of a ship not having a continuous bulkhead deck, the floodable length at any point may be determined to an assumed continuous margin line which at no point is less than 76 millimetres (3 inches) below the top of the deck (at side) to which the bulkheads concerned and the shell are carried watertight.
- (ii) Where a portion of an assumed margin line is appreciably below the deck to which bulkheads are carried, the Administration may permit a limited relaxation in the watertightness of those portions of the bulkheads which are above the margin line and immediately under the higher deck.

Regulation 4. Permeability

- (a) The definite assumptions referred to in Regulation 3 of this Chapter relate to the permeabilities of the spaces below the margin line.

² Instead of the requirements in this Part, the Regulations on Subdivision and Stability of Passenger Ships as an Equivalent to Part B of Chapter II of the International Convention for the Safety of Life at Sea, 1960, adopted by the Organization by Resolution A.265 (VIII), may be used, if applied, in their entirety.

In determining the floodable length, a uniform average permeability shall be used throughout the whole length of each of the following portions of the ship below the margin line:

- (i) the machinery space as defined in Regulation 2 of this Chapter;
 - (ii) the portion forward of the machinery space; and
 - (iii) the portion abaft the machinery space.
- (b) (i) The uniform average permeability throughout the machinery space shall be determined from the formula -

$$85 + 10 \left(\frac{a - c}{v} \right)$$

where:

a = volume of the passenger spaces, as defined in Regulation 2 of this Chapter, which are situated below the margin line within the limits of the machinery space;

c = volume of between deck spaces below the margin line within the limits of the machinery space which are appropriated to cargo, coal or stores;

v = whole volume of the machinery space below the margin line.

- (ii) Where it is shown to the satisfaction of the Administration that the average permeability calculated value may be used. For the purpose of such calculation, the permeabilities of passenger spaces, as defined in Regulation 2 of this Chapter, shall be taken as 95, that of all cargo, coal and store spaces as 60, and that of double bottom, oil fuel and other tanks at such values as may be approved in each case.
- (c) Except as provided in paragraph (d) of this Regulation, the uniform average permeability throughout the portion of the ship before (or abaft) the machinery space shall be determined from the formula –

$$63 + 35 \frac{a}{v}$$

where:

a = volume of the passenger spaces, as defined in Regulation 2 of this Chapter, which are situated below the margin line, before (or abaft) the machinery space, and

v = whole volume of the portion of the ship below the margin line before (or abaft) the machinery space.

- (d) In the case of a ship which is permitted under paragraph (c) of Regulation 27 of Chapter III to carry a number of persons on board in excess of the lifeboat capacity provided, and is required under paragraph (d) of Regulation 1 of this Chapter to comply with special provisions, the uniform average permeability throughout the portion of the ship before (or abaft) the machinery space shall be determined from the formula –

$$95 - 35 \frac{b}{v}$$

where:

b = the volume of the spaces below the margin line and above the tops of floors, inner bottom, or peak tanks, as the case may be, which are appropriated to and used as cargo spaces, coal or oil fuel bunkers, store-rooms, baggage and mail rooms, chain lockers and fresh water tanks, before (or abaft) the machinery space; and

v = whole volume of the portion of the ship below the margin line before (or abaft) the machinery space.

In the case of ships engaged on services where the cargo holds are not generally occupied by any substantial quantities of cargo, no part of the cargo spaces is to be included in calculating "b".

- (e) In the case of unusual arrangements the Administration may allow, or require, a detailed calculation of average permeability for the portions before or abaft the machinery space. For the purpose of such calculation, the permeability of passenger spaces as defined in Regulation 2 of this Chapter shall be taken as 95, that of spaces containing machinery as 85, that of all cargo, coal and store spaces as 60, and that of double bottom, oil fuel and other tanks at such value as may be approved in each case.
- (f) Where a between deck compartment between two watertight transverse bulkheads contains any passenger or crew space, the whole of that compartment, less any space completely enclosed within permanent steel bulkheads and appropriated to other purposes, shall be regarded as passenger space. Where, however, the passenger or crew space in question is completely enclosed within permanent steel bulkheads, only the space so enclosed need be considered as passenger space.

Regulation 5. Permissible Length of Compartments

- (a) Ships shall be as effectively subdivided as is possible having regard to the nature of the service for which they are intended. The degree of subdivision shall vary with the length of the ship and with the service, in such manner that the highest degree of subdivision corresponds with the ships of greatest length, primarily engaged in the carriage of passengers.
- (b) *Factor of subdivision.* The maximum permissible length of a compartment having its centre at any point in the ship's length is obtained from the floodable length by multiplying the latter by an appropriate factor called the factor of subdivision.

The factor of subdivision shall depend on the length of the ship, and for a given length shall vary according to the nature of the service for which the ship is intended. It shall decrease in a regular and continuous manner:

- (i) as the length of the ship increases, and
- (ii) from a factor A, applicable to ships primarily engaged in the carriage of cargo, to a factor B, applicable to ships primarily engaged in the carriage of passengers.

The variations of the factors A and B shall be expressed by the following formulae (I) and (II) where L is the length of the ship as defined in Regulation 2 of this Chapter:

L in metres:

$$A = \frac{58.2}{L-60} + .18 \quad (L = 131 \text{ and upwards}) \quad (\text{I})$$

L in feet:

$$A = \frac{190}{L-198} + .18 \quad (L = 430 \text{ and upwards})$$

L in metres:

$$B = \frac{30.3}{L-42} + .18 \quad (L = 79 \text{ and upwards}) \quad (\text{II})$$

L in feet:

$$B = \frac{100}{L-138} + .18 \quad (L = 260 \text{ and upwards})$$

- (c) *Criterion of service.* For a ship of given length the appropriate factor of subdivision shall be determined by the Criterion of Service Numeral (hereinafter called the Criterion Numeral) as given by the following formulae (III) and (IV) where:

C_s = the Criterion Numeral;

L = length of the ship, as defined in Regulation 2 of this Chapter;

M = the volume of the machinery space, as defined in Regulation 2 of this Chapter; with the addition thereto of the volume of any permanent oil fuel bunkers which may be situated above the inner bottom and before or abaft the machinery space;

P = the whole volume of the passenger spaces below the margin line, as defined in Regulation 2 of this Chapter;

V = the whole volume of the ship below the margin line; $P_1 = KN$ where:

$P_1 = KN$ where:

N = number of passengers for which the ship is to be certified, and

K has the following values:

	<i>Value of K</i>
Length in metres and volumes in cubic feet	0.56L
Length in feet and volumes in cubic feet6L

Where the value of KN is greater than the sum of P and the whole volume of the actual passenger spaces above the margin line, the figure to be taken as P_1 is that sum or two-thirds KN, whichever is the greater.

When P_1 is greater than P -

$$C_s = 72 \frac{M+2P_1}{V+P_1-P} \quad (\text{III})$$

and in other cases -

$$C_s = 72 \frac{M+2P}{V} \quad (\text{IV})$$

For ships not having a continuous bulkhead deck the volumes are to be taken up to the actual margin lines used in determining the floodable lengths.

(d) *Rules for subdivision of ships other than those covered by paragraph (e) of this Regulation*

- (i) The subdivision abaft the forepeak of ships 131 metres (430 feet) in length and upwards having a criterion numeral of 23 or less shall be governed by the factor A given by formula (I); of those having a criterion numeral of 123 or more by the factor B given by formula (II); and of those having a criterion numeral between 23 and 123 by the factor F obtained by linear interpolation between the factors A and B, using the formula:

$$F = A - \frac{(A-B)(C_s-23)}{100} \quad (\text{V})$$

Nevertheless, where the criterion numeral is equal to 45 or more and simultaneously the computed factor of subdivision as given by formula (V) is .65 or less, but more than .50, the subdivision abaft the forepeak shall be governed by the factor .50.

Where the factor F is less than .40 and it is shown to the satisfaction of the Administration to be impracticable to comply with the factor F in a machinery compartment of the ship, the subdivision of such compartment may be governed by an increased factor, which, however, shall not exceed .40.

- (ii) The subdivision abaft the forepeak of ships less than 131 metres (430 feet) but not less than 79 metres (260 feet) in length having a criterion numeral equal to S, where:

$$S = \frac{3,574-25L}{13} \text{ (L in metres)} = \frac{9,382-20L}{34} \text{ (L in feet)}$$

shall be governed by the factor unity; of those having a criterion numeral of 123 or more by the factor B given by the formula (II); of those having a criterion numeral between S and 123 by the factor F obtained by linear interpolation between unity and the factor B using the formula:

$$F = 1 - \frac{(1-B)(C_s-S)}{123-S} \quad (\text{VI})$$

- (iii) The subdivision abaft the forepeak of ships less than 131 metres (430 feet) but not less than 79 metres (260 feet) in length and having a criterion numeral less than S, and of all ships less than 79 metres (260 feet) in length shall be governed by the factor unity, unless, in either case, it is shown to the satisfaction of the Administration to be impracticable to comply with this factor in any part of the ship, in which case the Administration may allow such relaxation as may appear to be justified, having regard to all the circumstances.

- (iv) The provisions of sub-paragraph (iii) of this paragraph shall apply also to ships of whatever length, which are to be certified to carry a number of passengers exceeding 12 but not exceeding -

$$\frac{L^2}{650} \text{ (in metres)} = \frac{L^2}{7,000} \text{ (in feet), or 50, whichever is the less.}$$

(e) *Special standards of subdivision for ships which are permitted under paragraph (c) of Regulation 27 of Chapter III to carry a number of persons on board in excess of the lifeboat capacity provided and are required under paragraph (d) of Regulation 1 of this Chapter to comply with special provisions.*

- (i) (1) In the case of ships primarily engaged in the carriage of passengers, the subdivision abaft the forepeak shall be governed by a factor of .50 or by the factor determined according to paragraphs (c) and (d) of this Regulation, if less than .50.

(2) In the case of such ships less than 91.5 metres (300 feet) in length, if the Administration is satisfied that compliance with such factor would be impracticable in a compartment, it may allow the length of that compartment to be governed by a higher factor provided the factor used is the lowest that is practicable and reasonable in the circumstances.

- (ii) Where, in the case of any ship whether less than 91.5 metres (300 feet) or not, the necessity of carrying appreciable quantities of cargo makes it impracticable to require the subdivision abaft the forepeak to be governed by a factor not exceeding .50, the standard of subdivision to be applied shall be determined in accordance with the following sub-paragraphs (1) to (5), subject to the condition that where the Administration is satisfied that insistence on strict compliance in any respect would be unreasonable, it may allow such alternative arrangement of the watertight bulkheads as appears to be justified on merits and will not diminish the general effectiveness of the subdivision.

(1) The provisions of paragraph (c) of this Regulation relating to the criterion numeral shall apply with the exception that in calculating the value of P_1 for berthed passengers K is to have the value defined in paragraph (c) of this Regulation, or 3.55 cubic metres (125 cubic feet), whichever is the greater, and for unberthed passengers K is to have the value 3.55 cubic metres (125 cubic feet).

(2) The factor B in paragraph (b) of this Regulation shall be replaced by the factor BB determined by the following formula:

L in metres:

$$BB = \frac{17.6}{L - 33} + .20 \quad (L = 55 \text{ and upwards})$$

L in feet:

$$BB = \frac{57.6}{L - 108} + .20 \quad (L = 180 \text{ and upwards})$$

- (3) The subdivision abaft the forepeak of ships 131 metres (430 feet) in length and upwards having a criterion numeral of 23 or less shall be governed by the factor A given by formula (I) in paragraph (b) of this Regulation; of those having a criterion numeral of 123 or more by the factor BB given by the formula in sub-paragraph (ii)(2) of this paragraph; and of those having a criterion numeral between 23 and 123 by the factor F obtained by linear interpolation between the factors A and BB, using the formula:

$$F = A - \frac{(A - BB)(C_s - 23)}{100}$$

except that if the factor F so obtained is less than .50 the factor to be used shall be either .50 or the factor calculated according to the provisions of sub-paragraph (d)(i) of this Regulation, whichever is the smaller.

- (4) The subdivision abaft the forepeak of ships less than 131 metres (430 feet) but not less than 55 metres (180 feet) in length having a criterion numeral equal to S_1 where:

$$S_1 = \frac{3,712 - 25L}{19} \text{ (L in metres)}$$

$$S_1 = \frac{1,950 - 4L}{10} \text{ (L in feet)}$$

shall be governed by the factor unity; of those having a criterion numeral of 123 or more by the factor BB given by the formula in sub-paragraph (ii)(2) of this paragraph; of those having a criterion numeral between S_1 and 123 by the factor F obtained by linear interpolation between unity and the factor BB using the formula:

$$F = 1 - \frac{(1 - BB)(C_s - S_1)}{123 - S_1}$$

except that in either of the two latter cases if the factor so obtained is less than .50 the subdivision may be governed by a factor not exceeding .50.

- (5) The subdivision abaft the forepeak of ships less than 131 metres (430 feet) but not less than 55 metres (180 feet) in length and having a criterion numeral less than S_1 and of all ships less than 55 metres (180 feet) in length shall be governed by the factor unity, unless it is shown to the satisfaction of the Administration to be impracticable to comply with this factor in particular compartments, in which event the Administration may allow such relaxations in respect of those compartments as appear to be justified, having regard to all the circumstances, provided that the aftermost compartment and as many as possible of the forward compartments (between the forepeak and the after end of the machinery space) shall be kept within the floodable length.

Regulation 6. Special Rules Concerning Subdivision

- (a) Where in a portion or portions of a ship the watertight bulkheads are carried to a higher deck than in the remainder of the ship and it is desired to take advantage of this higher extension of the bulkheads in calculating the floodable length, separate margin lines may be used for each such portion of the ship provided that:

- (i) the sides of the ship are extended throughout the ship's length to the deck corresponding to the upper margin line and all openings in the shell plating below this deck throughout the length of the ship are treated as being below a margin line, for the purposes of Regulation 14 of this Chapter; and
 - (ii) the two compartments adjacent to the "step" in the bulkhead deck are each within the permissible length corresponding to their respective margin lines, and, in addition, their combined length does not exceed twice the permissible length based on the lower margin line.
- (b) (i) A compartment may exceed the permissible length determined by the rules of Regulation 5 of this Chapter provided the combined length of each pair of adjacent compartments to which the compartment in question is common does not exceed either the floodable length or twice the permissible length, whichever is the less.
- (ii) If one of the two adjacent compartments is situated inside the machinery space, and the second is situated outside the machinery space, and the average permeability of the portion of the ship in which the second is situated differs from that of the machinery space, the combined length of the two compartments shall be adjusted to the mean average permeability of the two portions of the ship in which the compartments are situated.
- (iii) Where the two adjacent compartments have different factors of subdivision, the combined length of the two compartments shall be determined proportionately.
- (c) In ships 100 metres (330 feet) in length and upwards, one of the main transverse bulkheads abaft the forepeak shall be fitted at a distance from forward perpendicular which is not greater than the permissible length.
- (d) A main transverse bulkhead may be recessed provided that all parts of the recess lie inboard of vertical surfaces on both sides of the ship, situated at a distance from the shell plating equal to one-fifth the breadth of the ship, as defined in Regulation 2 of this Chapter, and measured at right angles to the centre line at the level of the deepest subdivision load line.
- Any part of a recess which lies outside these limits shall be dealt with as a step in accordance with paragraph (e) of this Regulation.
- (e) A main transverse bulkhead may be stepped provided that it meets one of the following conditions:
- (i) the combined length of the two compartments, separated by the bulkhead in question, does not exceed either 90 per cent of the floodable length or twice the permissible length, except than in ships having a factor of subdivision greater than .9, the combined length of the two compartments in question shall not exceed the permissible length;
 - (ii) additional subdivision is provided in way of the step to maintain the same measure of safety as that secured by a plane bulkhead;
 - (iii) the compartment over which the step extends does not exceed the permissible length corresponding to a margin line taken 76 millimetres (3 inches) below the step.
- (f) Where a main transverse bulkhead is recessed or stepped, an equivalent plane bulkhead shall be used in determining the subdivision.

- (g) If the distance between two adjacent main transverse bulkheads, or their equivalent plane bulkheads, or the distance between the transverse planes passing through the nearest stepped portions of the bulkheads, is less than 3.05 metres (10 feet) plus 3 per cent of the length of the ship, or 10.67 metres (35 feet) whichever is the less, only one of these bulkheads shall be regarded as forming part of the subdivision of the ship in accordance with the provisions of Regulation 5 of this Chapter.
- (h) Where a main transverse watertight compartment contains local subdivision and it can be shown to the satisfaction of the Administration that, after any assumed side damage extending over a length of 3.05 metres (10 feet) plus 3 per cent of the length of the ship, or 10.67 metres (35 feet) whichever is the less, the whole volume of the main compartment will not be flooded, a proportionate allowance may be made in the permissible length otherwise required for such compartment. In such a case the volume of effective buoyancy assumed on the undamaged side shall not be greater than that assumed on the damaged side.
- (i) Where the required factor of subdivision is .50 or less, the combined length of any two adjacent compartments shall not exceed the floodable length.

Regulation 7. Stability of Ships in Damaged Condition

- (a) Sufficient intact stability shall be provided in all service conditions so as to enable the ship to withstand the final stage of flooding of any one main compartment which is required to be within the floodable length.

Where two adjacent main compartments are separated by a bulkhead which is stepped under the conditions of sub-paragraph (e)(i) of Regulation 6 of this Chapter the intact stability shall be adequate to withstand the flooding of those two adjacent main compartments.

Where the required factor of subdivision is .50 or less but more than .33, intact stability shall be adequate to withstand the flooding of any two adjacent main compartments.

Where the required factor of subdivision is .33 or less the intact stability shall be adequate to withstand the flooding of any three adjacent main compartments.

- (b)
 - (i) The requirements of paragraph (a) of this Regulation shall be determined by calculations which are in accordance with paragraphs (c), (d) and (f) of this Regulation and which take into consideration the proportions and design characteristics of the ship and the arrangement and configuration of the damaged compartments. In making these calculations the ship is to be assumed in the worst anticipated service condition as regards stability.
 - (ii) Where it is proposed to fit decks, inner skins or longitudinal bulkheads of sufficient tightness to seriously restrict the flow of water, the Administration shall be satisfied that proper consideration is given to such restrictions in the calculations.
 - (iii) In cases where the Administration considers the range of stability in the damaged condition to be doubtful, it may require investigation thereof.

- (c) For the purpose of making damage stability calculations the volume and surface permeabilities shall be in general as follows:

<i>Spaces</i>	<i>Permeability</i>
Appropriated to cargo, coal or stores	60
Occupied by accommodation	95
Occupied by machinery	85
Intended for Liquids	0 or 95 ³

Higher surface permeabilities are to be assumed in respect of spaces which, in the vicinity of the damage waterplane, contain no substantial quantity of accommodation or machinery and spaces which are not generally occupied by any substantial quantity of cargo or stores.

- (d) Assumed extent of damage shall be as follows:

- (i) longitudinal extent: 3.05 metres (10 feet) plus 3 per cent of the length of the ship, or 10.67 metres (35 feet) whichever is the less. Where the required factor of subdivision is .33 or less the assumed longitudinal extent of damage shall be increased as necessary so as to include any two consecutive main transverse watertight bulkheads;
- (ii) transverse extent (measured inboard from the ship's side, at right angles to the centre line at the level of the deepest subdivision load line): a distance of one-fifth of the breadth of the ship, as defined in Regulation 2 of this Chapter; and
- (iii) vertical extent: from the base line upwards without limit.
- (iv) If any damage of lesser extent than that indicated in sub-paragraphs (i), (ii) and (iii) of this paragraph would result in a more severe condition regarding heel or loss of metacentric height, such damage shall be assumed in the calculations.

- (e) Unsymmetrical flooding is to be kept to a minimum consistent with efficient arrangements. Where it is necessary to correct large angles of heel, the means adopted shall, where practicable, be self-acting, but in any case where controls to cross-flooding fittings are provided they shall be operable from above the bulkhead deck. These fittings together with their controls as well as the maximum heel before equalization shall be acceptable to the Administration. Where cross-flooding fittings are required the time for equalization shall not exceed 15 minutes. Suitable information concerning the use of cross-flooding fittings shall be supplied to the master of the ship.⁴

- (f) The final conditions of the ship after damage and, in the case of unsymmetrical flooding, after equalization measures have been taken shall be as follows:

- (i) in the case of symmetrical flooding there shall be a positive residual metacentric height of at least 50 millimetres (2 inches) as calculated by the constant displacement method;
- (ii) in the case of unsymmetrical flooding the total heel shall not exceed seven degrees, except that, in special cases, the Administration may allow additional heel due to the unsymmetrical moment, but in no case shall the final heel exceed fifteen degrees;

³ Whichever results in the more severe requirements.

⁴ Reference is made to the Recommendation on a Standard Method for Establishing Compliance with the Requirements for Cross-Flooding Arrangements in Passenger Ships, adopted by the Organization by Resolution A.266(VII).

- (iii) in no case shall the margin line be submerged in the final stage of flooding. If it is considered that the margin line may become submerged during an intermediate stage of flooding, the Administration may require such investigations and arrangements as it considers necessary for the safety of the ship.
- (g) The master of the ship shall be supplied with the data necessary to maintain sufficient intact stability under service conditions to enable the ship to withstand the critical damage. In the case of ships requiring cross-flooding the master of the ship shall be informed of the conditions of stability on which the calculations of heel are based and be warned that excessive heeling might result should the ship sustain damage when in a less favourable condition.
- (h)
 - (i) No relaxation from the requirements for damage stability may be considered by the Administration unless it is shown that the intact metacentric height in any service condition necessary to meet these requirements is excessive for the service intended.
 - (ii) Relaxations from the requirements for damage stability shall be permitted only in exceptional cases and subject to the condition that the Administration is to be satisfied that the proportions, arrangements and other characteristics of the ship are the most favourable to stability after damage which can practically and reasonably be adopted in the particular circumstances.

Regulation 8. Ballasting

When ballasting with water is necessary, the water ballast should not in general be carried in tanks intended for oil fuel. In ships in which it is not practicable to avoid putting water in oil fuel tanks, oily-water separator equipment to the satisfaction of the Administration shall be fitted, or other alternative means acceptable to the Administration shall be provided for disposing of the oily-water ballast.

Regulation 9. Peak and Machinery Space Bulkheads, Shaft Tunnels, etc.

- (a)
 - (i) A ship shall have a forepeak or collision bulkhead, which shall be watertight up to the bulkhead deck. This bulkhead shall be fitted not less than 5 per cent of the length of the ship, and not more than 3.05 metres (10 feet) plus 5 per cent of the length of the ship from the forward perpendicular.
 - (ii) If the ship has a long forward superstructure, the forepeak bulkhead shall be extended weathertight to the deck next above the bulkhead deck. The extension need not be fitted directly over the bulkhead below, provided it is at least 5 per cent of the length of the ship from the forward perpendicular, and the part of the bulkhead deck which forms the step is made effectively weathertight.
- (b) An afterpeak bulkhead, and bulkheads dividing the machinery space, as defined in Regulation 2 of this Chapter, from the cargo and passenger spaces forward and aft, shall also be fitted and made watertight up to the bulkhead deck. The afterpeak bulkhead may, however, be stepped below the bulkhead deck, provided the degree of safety of the ship as regards subdivision is not thereby diminished.
- (c) In all cases stem tubes shall be enclosed in watertight spaces of moderate volume. The stern gland shall be situated in a watertight shaft tunnel or other watertight space separate from the stern tube compartment and of such volume that, if flooded by leakage through the stern gland, the margin line will not be submerged.

Regulation 10. Double Bottoms

- (a) A double bottom shall be fitted extending from the forepeak bulkhead to the after peak bulkhead as far as this is practicable and compatible with the design and proper working of the ship.
- (i) In ships 50 metres (165 feet) and under 61 metres (200 feet) in length a double bottom shall be fitted at least from the machinery space to the forepeak bulkhead, or as near thereto as practicable.
- (ii) In ships 61 metres (200 feet) and under 76 metres (249 feet) in length a double bottom shall be fitted at least outside the machinery space, and shall extend to the fore and after peak bulkheads, or as near thereto as practicable.
- (iii) In ships 76 metres (249 feet) in length and upwards, a double bottom shall be fitted amidships, and shall extend to the fore and after peak bulkheads, or as near thereto as practicable.
- (b) Where a double bottom is required to be fitted its depth shall be to the satisfaction of the Administration and the inner bottom shall be continued out to the ship's sides in such a manner as to protect the bottom to the turn of the bilge. Such protection will be deemed satisfactory if the line of intersection of the outer edge of the margin plate with the bilge plating is not lower at any part than a horizontal plane passing through the point of intersection with the frame line amidships of a transverse diagonal line inclined at 25 degrees to the base line and cutting it at a point one-half the ship's moulded breadth from the middle line.
- (c) Small wells constructed in the double bottom in connexion with drainage arrangements of holds, *etc.*, shall not extend downwards more than necessary. The depth of the well shall in no case be more than the depth less 457 millimetres (18 inches) of the double bottom at the centreline, nor shall the well extend below the horizontal plane referred to in paragraph (b) of this Regulation. A well extending to the outer bottom is, however, permitted at the after end of the shaft tunnel of screw-ships. Other wells (e.g., for lubricating oil under main engines) may be permitted by the Administration if satisfied that the arrangements give protection equivalent to that afforded by a double bottom complying with this Regulation.
- (d) A double bottom need not be fitted in way of watertight compartments of moderate size used exclusively for the carriage of liquids, provided the safety of the ship, in the event of bottom or side damage, is not, in the opinion of the Administration, thereby impaired.
- (e) In the case of ships to which the provisions of paragraph (d) of Regulation 1 of this Chapter apply and which are engaged on regular service within the limits of a short international voyage as defined in Regulation 2 of Chapter III, the Administration may permit a double bottom to be dispensed with in any part of the ship which is subdivided by a factor not exceeding .50, if satisfied that the fitting of a double bottom in that part would not be compatible with the design and proper working of the ship.

Regulation 11. Assigning, Marking and Recording of Subdivision Load Lines

- (a) In order that the required degree of subdivision shall be maintained, a load line corresponding to the approved subdivision draught shall be assigned and marked on the ship's sides. A ship having spaces which are specially adapted for the accommodation of passengers and the carriage of cargo alternatively may, if the owners desire, have one or more additional load lines assigned and marked to correspond with the subdivision draughts which the Administration may approve for the alternative service conditions.

- (b) The subdivision load lines assigned and marked shall be recorded in the Passenger Ship Safety Certificate, and shall be distinguished by the notation C.1 for the principal passenger condition, and C.2, C.3, *etc.*, for the alternative conditions.
- (c) The freeboard corresponding to each of these load lines shall be measured at the same position and from the same deck line as the freeboards determined in accordance with the International Convention respecting Load Lines in force.
- (d) The freeboard corresponding to each approved subdivision load line and the conditions of service for which it is approved, shall be clearly indicated on the Passenger Ship Safety Certificate.
- (e) In no case shall any subdivision load line mark be placed above the deepest load line in salt water as determined by the strength of the ship and/or the International Convention respecting Load Lines in force.
- (f) Whatever may be the position of the subdivision load line marks, a ship shall in no case be loaded so as to submerge the load line mark appropriate to the season and locality as determined in accordance with the International Convention respecting Load Lines in force.
- (g) A ship shall in no case be so loaded that when she is in salt water the subdivision load line mark appropriate to the particular voyage and condition of service is submerged.

Regulation 12. Construction and Initial Testing of Watertight Bulkheads, etc.

- (a) Each watertight subdivision bulkhead, whether transverse or longitudinal, shall be constructed in such a manner that it shall be capable of supporting, with a proper margin of resistance, the pressure due to the maximum head of water which it might have to sustain in the event of damage to the ship but at least the pressure due to a head of water up to the margin line. The construction of these bulkheads shall be to the satisfaction of the Administration.
- (b) (i) Steps and recesses in bulkheads shall be watertight and as strong as the bulkhead at the place where each occurs.

(ii) Where frames or beams pass through a watertight deck or bulkhead, such deck or bulkhead shall be made structurally watertight without the use of wood or cement.
- (c) Testing main compartments by filling them with water is not compulsory. When testing by filling with water is not carried out, a hose test is compulsory; this test shall be carried out in the most advanced stage of the fitting out of the ship. In any case, a thorough inspection of the watertight bulkheads shall be carried out.
- (d) The forepeak, double bottoms (including duct keels) and inner skins shall be tested with water to a head corresponding to the requirements of paragraph (a) of this Regulation.
- (e) Tanks which are intended to hold liquids, and which form part of the subdivision of the ship, shall be tested for tightness with water to a head up to the deepest subdivision load line or to a head corresponding to two-thirds of the depth from the top of keel to the margin line in way of the tanks, whichever is the greater; provided that in no case shall the test head be less than 0.92 metres (3 feet) above the top of the tank.

- (f) The tests referred to in paragraphs (d) and (e) of this Regulation are for the purpose of ensuring that the subdivision structural arrangements are watertight and are not to be regarded as a test of the fitness of any compartment for the storage of oil fuel or for other special purposes for which a test of a superior character may be required depending on the height to which the liquid has access in the tank or its connexions.

Regulation 13. Openings in Watertight Bulkheads

- (a) The number of openings in watertight bulkheads shall be reduced to the minimum compatible with the design and proper working of the ship; satisfactory means shall be provided for closing these openings.
- (b) (i) Where pipes, scuppers, electric cables, *etc.* are carried through watertight subdivision bulkheads, arrangements shall be made to ensure the integrity of the water tightness of the bulkheads.
- (ii) Valves and cocks not forming part of a piping system shall not be permitted in watertight subdivision bulkheads.
- (iii) Lead or other heat sensitive materials shall not be used in systems which penetrate watertight subdivision bulkheads, where deterioration of such systems in the event of fire would impair the watertight integrity of the bulkheads.
- (c) (i) No doors, manholes, or access openings are permitted:
- (1) in the collision bulkhead below the margin line;
- (2) in watertight transverse bulkheads dividing a cargo space from an adjoining cargo space or from a permanent or reserve bunker, except as provided in paragraph (1) of this Regulation.
- (ii) Except as provided in sub-paragraph (iii) of this paragraph, the collision bulkhead may be pierced below the margin line by not more than one pipe for dealing with fluid in the forepeak tank, provided that the pipe is fitted with a screwdown valve capable of being operated from above the bulkhead deck, the valve chest being secured inside the forepeak to the collision bulkhead.
- (iii) If the forepeak is divided to hold two different kinds of liquids the Administration may allow the collision bulkhead to be pierced below the margin line by two pipes, each of which is fitted as required by sub-paragraph (ii) of this paragraph, provided the Administration is satisfied that there is no practical alternative to the fitting of such a second pipe and that, having regard to the additional subdivision provided in the forepeak, the safety of the ship is maintained.
- (d) (i) Watertight doors fitted in bulkheads between permanent and reserve bunkers shall be always accessible, except as provided in sub-paragraph (ii) of paragraph (k) of this Regulation for between deck bunker doors.
- (ii) Satisfactory arrangements shall be made by means of screens or otherwise to prevent the coal from interfering with the closing of watertight bunker doors.

- (e) Within spaces containing the main and auxiliary propelling machinery including boilers serving the needs of propulsion and all permanent bunkers, not more than one door apart from the doors to bunkers and shaft tunnels may be fitted in each main transverse bulkhead. Where two or more shafts are fitted the tunnels shall be connected by an inter-communicating passage. There shall be only one door between the machinery space and the tunnel spaces where two shafts are fitted and only two doors where there are more than two shafts. All these doors shall be of the sliding type and shall be located so as to have their sills as high as practicable. The hand gear for operating these doors from above the bulkhead deck shall be situated outside the spaces containing the machinery if this is consistent with a satisfactory arrangement of the necessary gearing.
- (f) (i) Watertight doors shall be sliding doors or hinged doors or doors of an equivalent type. Plate doors secured only by bolts and doors required to be closed by dropping or by the action of a dropping weight are not permitted.
- (ii) Sliding doors may be either:
- hand-operated only, or
 - power-operated as well as hand-operated.
- (iii) Authorized watertight doors may therefore be divided into three Classes:
- Class 1, hinged doors;
 - Class 2, hand-operated sliding doors;
 - Class 3, sliding doors which are power-operated as well as hand-operated.
- (iv) The means of operation of any watertight door whether power-operated or not shall be capable of closing the door with the ship listed to 15 degrees either way.
- (v) In all classes of watertight doors indicators shall be fitted which show, at all operating stations from which the doors are not visible, whether the doors are open or closed. If any of the watertight doors, of whatever Class, is not fitted so as to enable it to be closed from a central control station, it shall be provided with a mechanical, electrical, telephonic, or any other suitable direct means of communication, enabling the officer of the watch promptly to contact the person who is responsible for closing the door in question, under previous orders.
- (g) Hinged doors (Class 1) shall be fitted with quick action closing devices, such as catches, workable from each side of the bulkhead.
- (h) Hand-operated sliding doors (Class 2) may have a horizontal or vertical motion. It shall be possible to operate the mechanism at the door itself from either side, and in addition, from an accessible position above the bulkhead deck, with an all round crank motion, or some other movement providing the same guarantee of safety and of an approved type. Departures from the requirement of operation on both sides may be allowed, if this requirement is impossible owing to the layout of the spaces. When operating a hand gear the time necessary for the complete closure of the door with the vessel upright, shall not exceed 90 seconds.
- (i) (i) Power-operated sliding doors (Class 3) may have a vertical or horizontal motion. If a door is required to be power-operated from a central control, the gearing shall be so arranged that the door can be operated by power also at the door itself from both sides. The arrangement shall be such that the door will close automatically if opened by local control after being closed from the central control, and also such that any door can be kept closed by local systems which will prevent the door from being opened from the upper control. Local control handles in connexion with the power gear shall be provided each side of the

bulkhead and shall be so arranged as to enable persons passing through the doorway to hold both handles in the open position without being able to set the closing mechanism in operation accidentally. Power-operated sliding doors shall be provided with hand gear workable at the door itself on either side and from an accessible position above the bulkhead deck, with an all round crank motion or some other movement providing the same guarantee of safety and of an approved type. Provision shall be made to give warnings by sound signal that the door has begun to close and will continue to move until it is completely closed. The door shall take a sufficient time to close to ensure safety.

- (ii) There shall be at least two independent power sources capable of opening and closing all the doors under control, each of them capable of operating all the doors simultaneously. The two power sources shall be controlled from the central station on the bridge provided with all the necessary indicators for checking that each of the two power sources is capable of giving the required service satisfactorily.
- (iii) In the case of hydraulic operation, each power source shall consist of a pump capable of closing all doors in not more than 60 seconds. In addition, there shall be for the whole installation hydraulic accumulators of sufficient capacity to operate all the doors at least three times, i.e., closed-open- closed. The fluid used shall be one which does not freeze at any of the temperatures liable to be encountered by the ship during its service.
- (j) (i) Hinged watertight doors (Class 1) in passenger, crew and working spaces are only permitted above a deck the underside of which, at its lowest point at side, is at least 2.13 metres (7 feet) above the deepest subdivision load line.
- (ii) Watertight doors, the sills of which are above the deepest load line and below the line specified in the preceding sub-paragraph shall be sliding doors and may be hand-operated (Class 2), except in vessels engaged on short international voyages and required to have a factor of subdivision of .50 or less in which all such doors shall be power-operated. When trunkways in connexion with refrigerated cargo and ventilation or forced draught ducts are carried through more than one main watertight subdivision bulkhead, the doors at such openings shall be operated by power.
- (k) (i) Watertight doors which may sometimes be opened at sea, and the sills of which are below the deepest subdivision load line shall be sliding doors. The following rules shall apply:
 - (1) when the number of such doors (excluding doors at entrances to shaft tunnels) exceeds five, all of these doors and those at the entrance to shaft tunnels or ventilation or forced draught ducts, shall be power-operated (Class 3) and shall be capable of being simultaneously closed from a central station situated on the bridge;
 - (2) when the number of such doors (excluding doors at entrances to shaft tunnels) is greater than one, but does not exceed five,
 - (a) where the ship has no passenger spaces below the bulkhead deck, all the above-mentioned doors may be hand-operated (Class 2);
 - (b) where the ship has passenger spaces below the bulkhead deck all the above-mentioned doors shall be power-operated (Class 3) and shall be capable of being simultaneously closed from a central station situated on the bridge;

- (3) in any ship where there are only two such watertight doors and they are into or within the space containing machinery, the Administration may allow these two doors to be hand-operated only (Class 2).
- (ii) If sliding watertight doors which have sometimes to be open at sea for the purpose of trimming coal are fitted between bunkers in the between decks below the bulkhead deck, these doors shall be operated by power. The opening and closing of these doors shall be recorded in such log book as may be prescribed by the Administration.
- (l) (i) If the Administration is satisfied that such doors are essential, watertight doors of satisfactory construction may be fitted in watertight bulkheads dividing cargo between deck spaces. Such doors may be hinged, rolling or sliding doors but shall not be remotely controlled. They shall be fitted at the highest level and as far from the shell plating as practicable, but in no case shall the outboard vertical edges be situated at a distance from the shell plating which is less than one-fifth of the breadth of the ship, as defined in Regulation 2 of this Chapter, such distance being measured at right angles to the centre line of the ship at the level of the deepest subdivision load line.
- (ii) Such doors shall be closed before the voyage commences and shall be kept closed during navigation; and the time of opening such doors in port and of closing them before the ship leaves port shall be entered in the log book. Should any of the doors be accessible during the voyage, they shall be fitted with a device which prevents unauthorized opening. When it is proposed to fit such doors, the number and arrangements shall receive the special consideration of the Administration.
- (m) Portable plates on bulkheads shall not be permitted except in machinery spaces. Such plates shall always be in place before the ship leaves port, and shall not be removed during navigation except in case of urgent necessity. The necessary precautions shall be taken in replacing them to ensure that the joints shall be watertight.
- (n) All watertight doors shall be kept closed during navigation except when necessarily opened for the working of the ship, and shall always be ready to be immediately closed.
- (o) (i) Where trunkways or tunnels for access from crew accommodation to the stokehold, for piping, or for any other purpose are carried through main transverse watertight bulkheads, they shall be watertight and in accordance with the requirements of Regulation 16 of this Chapter. The access to at least one end of each such tunnel or trunkway, if used as a passage at sea, shall be through a trunk extending watertight to a height sufficient to permit access above the margin line. The access to the other end of the trunkway or tunnel may be through a watertight door of the type required by its location in the ship. Such trunkways or tunnels shall not extend through the first subdivision bulkhead abaft the collision bulkhead.
- (ii) Where it is proposed to fit tunnels or trunkways for forced draught, piercing main transverse watertight bulkheads, these shall receive the special consideration of the Administration.

Regulation 14. Openings in the Shell Plating Below the Margin Line

- (a) The number of openings in the shell plating shall be reduced to the minimum compatible with the design and proper working of the ship.

- (b) The arrangement and efficiency of the means for closing any opening in the shell plating shall be consistent with its intended purpose and the position in which it is fitted and generally to the satisfaction of the Administration.
- (c) (i) If in a between decks, the sills of any sidescuttles are below a line drawn parallel to the bulkhead deck at side and having its lowest point 21/2 per cent of the breadth of the ship above the deepest sub-division load line, all sidescuttles in that between deck shall be of the non-opening type.
- (ii) All sidescuttles the sills of which are below the margin line, other than those required to be of a non-opening type by sub-paragraph (i) of this paragraph, shall be of such construction as will effectively prevent any person opening them without the consent of the master of the ship.
- (iii) (1) Where in a between decks, the sills of any of the sidescuttles referred to in sub-paragraph (ii) of this paragraph are below a line drawn parallel to the bulkhead deck at side and having its lowest point 1.37 metres (4½ feet) plus 2½ per cent of the breadth of the ship above the water when the ship departs from any port, all the sidescuttles in that between decks shall be closed watertight and locked before the ship leaves port, and they shall not be opened before the ship arrives at the next port. In the application of this sub-paragraph the appropriate allowance for fresh water may be made when applicable.
- (2) The time of opening such sidescuttles in port and of closing and locking them before the ship leaves port shall be entered in such log book as may be prescribed by the Administration.
- (3) For any ship that has one or more sidescuttles so placed that the requirements of clause (1) of this sub-paragraph would apply when she was floating at her deepest subdivision load line, the Administration may indicate the limiting mean draught at which these sidescuttles will have their sills above the line drawn parallel to the bulkhead deck at side, and having its lowest point 1.37 metres (4½ feet) plus 2½ per cent of the breadth of the ship above the water-line corresponding to the limiting mean draught, and at which it will therefore be permissible to depart from port without previously closing and locking them and to open them at sea on the responsibility of the master during the voyage to the next port. In tropical zones as defined in the International Convention respecting Load Lines in force, this limiting draught may be increased by 0.305 metres (1 foot).
- (d) Efficient hinged inside deadlights arranged so that they can be easily and effectively closed and secured watertight shall be fitted to all sidescuttles except that abaft one-eighth of the ship's length from the forward perpendicular and above a line drawn parallel to the bulkhead deck at side and having its lowest point at a height of 3.66 metres (12 feet) plus 21/2 per cent of the breadth of the ship above the deepest subdivision load line, the deadlights may be portable in passenger accommodation other than that for steerage passengers, unless the deadlights are required by the International Convention respecting Load Lines in force to be permanently attached in their proper positions. Such portable deadlights shall be stowed adjacent to the sidescuttles they serve.
- (e) Sidescuttles and their deadlights, which will not be accessible during navigation, shall be closed and secured before the ship leaves port.

- (f) (i) No sidescuttles shall be fitted in any spaces which are appropriated exclusively to the carriage of cargo or coal.
- (ii) Sidescuttles may, however, be fitted in spaces appropriated alternatively to the carriage of cargo or passengers, but they shall be of such construction as will effectively prevent any person opening them or their deadlights without the consent of the master of the ship.
- (iii) If cargo is carried in such spaces, the sidescuttles and their deadlights shall be closed watertight and locked before the cargo is shipped and such closing and locking shall be recorded in such log books as may be prescribed by the Administration.
- (g) Automatic ventilating sidescuttles shall not be fitted in the shell plating below the margin line without the special sanction of the Administration.
- (h) The number of scuppers, sanitary discharges and other similar openings in the shell plating shall be reduced to the minimum either by making each discharge serve for as many as possible of the sanitary and other pipes, or in any other satisfactory manner.
- (i) (i) All inlets and discharges in the shell plating shall be fitted with efficient and accessible arrangements for preventing the accidental admission of water into the ship. Lead or other heat sensitive materials shall not be used for pipes fitted outboard of shell valves in inlets or discharges, or any other application where the deterioration of such pipes in the event of fire would give rise to danger of flooding.
- (ii) (1) Except as provided in sub-paragraph (iii) of this paragraph, each separate discharge led through the shell plating from spaces below the margin line shall be provided either with one automatic non-return valve fitted with a positive means of closing it from above the bulkhead deck, or, alternatively, with two automatic non-return valves without such means, the upper of which is so situated above the deepest subdivision load line as to be always accessible for examination under service conditions, and is of a type which is normally closed.
- (2) Where a valve with positive means of closing is fitted, the operating position above the bulkhead deck shall always be readily accessible, and means shall be provided for indicating whether the valve is open or closed.
- (iii) Main and auxiliary sea inlets and discharges in connexion with machinery shall be fitted with readily accessible cocks or valves between the pipes and shell plating or between the pipes and fabricated boxes attached to the shell plating.
- (j) (i) Gangway, cargo and coaling ports fitted below the margin line shall be of sufficient strength. They shall be effectively closed and secured watertight before the ship leaves port, and shall be kept closed during navigation.
- (ii) Such ports shall be in no case fitted so as to have their lowest point below the deepest subdivision load line.
- (k) (i) The inboard opening of each ash-shoot, rubbish-shoot, *etc.* shall be fitted with an efficient cover.
- (ii) If the inboard opening is situated below the margin line, the cover shall be watertight, and in addition an automatic non-return valve shall be fitted in the shoot in an easily accessible position above the deepest subdivision load line. When the shoot is not in use both the cover and the valve shall be kept closed and secured.

Regulation 15. Construction and Initial Tests of Watertight Doors, Sidescuttles, etc.

- (a) (i) The design, materials and construction of all watertight doors, sidescuttles, gangway, cargo and coaling ports, valves, pipes, ash-shoots and rubbish- shoots referred to in these Regulations shall be to the satisfaction of the Administration.
- (ii) The frames of vertical watertight doors shall have no groove at the bottom in which dirt might lodge and prevent the door closing properly.
- (iii) All cocks and valves for sea inlets and discharges below the bulkhead deck and all fittings outboard of such cocks and valves shall be made of steel, bronze or other approved ductile material. Ordinary cast iron or similar materials shall not be used.
- (b) Each watertight door shall be tested by water pressure to a head up to the bulkhead deck. The test shall be made before the ship is put in service, either before or after the door is fitted.

Regulation 16. Construction and Initial Tests of Watertight Decks, Trunks, etc.

- (a) Watertight decks, trunks, tunnels, duct keels and ventilators shall be of the same strength as watertight bulkheads at corresponding levels. The means used for making them watertight, and the arrangements adopted for closing openings in them, shall be to the satisfaction of the Administration. Watertight ventilators and trunks shall be carried at least up to the bulkhead deck.
- (b) After completion, a hose or flooding test shall be applied to watertight decks and a hose test to watertight trunks, tunnels and ventilators.

Regulation 17. Watertight Integrity Above the Margin Line

- (a) The Administration may require that all reasonable and practicable measures shall be taken to limit the entry and spread of water above the bulkhead deck. Such measures may include partial bulkheads or webs. When partial watertight bulkheads and webs are fitted on the bulkhead deck, above or in the immediate vicinity of main subdivision bulkheads, they shall have watertight shell and bulkhead deck connexions so as to restrict the flow of water along the deck when the ship is in a heeled damaged condition. Where the partial watertight bulkhead does not line up with the bulkhead below, the bulkhead deck between shall be made effectively watertight.
- (b) The bulkhead deck or a deck above it shall be weathertight in the sense that in ordinary sea conditions water will not penetrate in a downward direction. All openings in the exposed weather deck shall have coamings of ample height and strength and shall be provided with efficient means for expeditiously closing them weathertight. Freeing ports, open rails and/or scuppers shall be fitted as necessary for rapidly clearing the weather deck of water under all weather conditions.
- (c) Sidescuttles, gangway, cargo and coaling ports and other means for closing openings in the shell plating above the margin line shall be of efficient design and construction and of sufficient strength having regard to the spaces in which they are fitted and their positions relative to the deepest subdivision load line.
- (d) Efficient inside deadlights, arranged so that they can be easily and effectively closed and secured watertight, shall be provided for all sidescuttles to spaces below the first deck above the bulkhead deck.

Regulation 18. Bilge Pumping Arrangements in Passenger Ships

(a) Ships shall be provided with an efficient bilge pumping plant capable of pumping from and draining any watertight compartment which is neither a permanent oil compartment nor a permanent water compartment under all practicable conditions after a casualty whether the ship is upright or listed. For this purpose, wing suction will generally be necessary except in narrow compartments at the ends of the ship where one suction may be sufficient. In compartments of unusual form, additional suction may be required. Arrangements shall be made whereby water in the compartment may find its way to the suction pipes. Where in relation to particular compartments the Administration is satisfied that the provision of drainage may be undesirable, it may allow such provision to be dispensed with if calculations made in accordance with the conditions laid down in paragraph (b) of Regulation 7 of this Chapter show that the safety of the ship will not be impaired. Efficient means shall be provided for draining water from insulated holds.

(b) (i) Ships shall have at least three power pumps connected to the bilge main, one of which may be attached to the propelling unit. Where the criterion numeral is 30 or more, one additional independent power pump shall be provided.

(ii) The requirements are summarized in the following table:

<i>Criterion Numeral</i>	<i>Less than 30</i>	<i>30 and over</i>
Main Engine Pump (may be replaced by one independent pump)	1	1
Independent Pumps	2	3

(iii) Sanitary, ballast and general service pumps may be accepted as independent power bilge pumps if fitted with the necessary connections to the bilge pumping system.

(c) Where practicable, the power bilge pumps shall be placed in separate watertight compartments so arranged or situated that these compartments will not readily be flooded by the same damage. If the engines and boilers are in two or more watertight compartments, the pumps available for bilge service shall be distributed throughout these compartments as far as is possible.

(d) On ships 91.5 metres (300 feet) or more in length or having a criterion numeral of 30 or more, the arrangements shall be such that at least one power pump shall be available for use in all ordinary circumstances in which a ship may be flooded at sea. This requirement will be satisfied if:

(i) one of the required pumps is an emergency pump of a reliable submersible type having a source of power situated above the bulkhead deck; or

(ii) the pumps and their sources of power are so disposed throughout the length of the ship that under any condition of flooding which the ship is required to withstand, at least one pump in an undamaged compartment will be available.

(e) With the exception of additional pumps which may be provided for peak compartments only, each required bilge pump shall be arranged to draw water from any space required to be drained by paragraph (a) of this Regulation.

- (f) (i) Each power bilge pump shall be capable of giving a speed of water through the required main bilge pipe of not less than 122 metres (400 feet) per minute. Independent power bilge pumps situated in machinery spaces shall have direct suction from these spaces, except that not more than two such suction shall be required in any one space. Where two or more such suction are provided there shall be at least one on the port side and one on the starboard side. The Administration may require independent power bilge pumps situated in other spaces to have separate direct suction. Direct suction shall be suitably arranged and those in a machinery space shall be of a diameter not less than that required for the bilge main.
- (ii) In coal-burning ships there shall be provided in the stokehold, in addition to the other suction required by this Regulation, a flexible suction hose of suitable diameter and sufficient length, capable of being connected to the suction side of an independent power pump.
- (g) (i) In addition to the direct bilge suction or suction required by paragraph (f) of this Regulation there shall be in the machinery space a direct suction from the main circulating pump leading to the drainage level of the machinery space and fitted with a non-return valve. The diameter of this direct suction pipe shall be at least two-thirds of the diameter of the pump inlet in the case of steamships, and of the same diameter as the pump inlet in the case of motorships.
- (ii) Where in the opinion of the Administration the main circulating pump is not suitable for this purpose, a direct emergency bilge suction shall be led from the largest available independent power driven pump to the drainage level of the machinery space; the suction shall be of the same diameter as the main inlet of the pump used. The capacity of the pump so connected shall exceed that of a required bilge pump by an amount satisfactory to the Administration.
- (iii) The spindles of the sea inlet and direct suction valves shall extend well above the engine room platform.
- (iv) Where the fuel is, or may be, coal and there is no watertight bulkhead between the engines and the boilers, a direct discharge overboard or alternatively a by-pass to the circulating pump discharge, shall be fitted from any circulating pump used in compliance with subparagraph (i) of this paragraph.
- (h) (i) All pipes from the pumps which are required for draining cargo or machinery spaces shall be entirely distinct from pipes which may be used for filling or emptying spaces where water or oil is carried.
- (ii) All bilge pipes used in or under coal bunkers or fuel storage tanks or in boiler or machinery spaces, including spaces in which oil-settling tanks or oil fuel pumping units are situated, shall be of steel or other approved material.

- (i) The diameter of the bilge main shall be calculated according to the following formulae provided that the actual internal diameter of the bilge main may be of the nearest standard size acceptable to the Administration.

$$d = 1.68 \sqrt{L(B + D)} + 25$$

where:

d = internal diameter of the bilge main in millimetres,

L and B are the length and the breadth of the ship in metres, as defined in Regulation 2 of this Chapter, and

D = moulded depth of the ship to bulkhead deck in metres;

or

$$d = \sqrt{\frac{L(B + D)}{2500}} + 1$$

where:

d = internal diameter of the bilge main in inches,

L and B are the length and the breadth of the ship in feet, as defined in Regulation 2 of this Chapter, and

D = moulded depth of the ship to bulkhead deck in feet.

The diameter of the bilge branch pipes shall be determined by rules to be made by the Administration.

- (j) The arrangement of the bilge and ballast pumping system shall be such as to prevent the possibility of water passing from the sea and from water ballast spaces into the cargo and machinery spaces, or from one compartment to another. Special provision shall be made to prevent any deep tank having bilge and ballast connexions being inadvertently run up from the sea when containing cargo, or pumped out through a bilge pipe when containing water ballast.
- (k) Provision shall be made to prevent the compartment served by any bilge suction pipe being flooded in the event of the pipe being severed, or otherwise damaged by collision or grounding in any other compartment. For this purpose, where the pipe is at any part situated nearer the side of the ship than one-fifth the breadth of the ship (measured at right angles to the centre line at the level of the deepest subdivision load line), or in a duct keel, a non-return valve shall be fitted to the pipe in the compartment containing the open end.
- (l) All the distribution boxes, cocks and valves in connexion with the bilge pumping arrangements shall be in positions which are accessible at all times under ordinary circumstances. They shall be so arranged that, in the event of flooding, one of the bilge pumps may be operative on any compartment; in addition, damage to a pump or its pipe connecting to the bilge main outboard of a line drawn at one-fifth of the breadth of the ship shall not put the bilge system out of action. If there is only one system of pipes common to all the pumps, the necessary cocks or valves for controlling the bilge suction must be capable of being operated from above the bulkhead deck. Where in addition to the main bilge pumping system an emergency bilge pumping system is provided, it shall be independent of the main system and so arranged that a pump is capable

of operating on any compartment under flooding conditions; in that case only the cocks and valves necessary for the operation of the emergency system need be capable of being operated from above the bulkhead deck.

- (m) All cocks and valves mentioned in paragraph (l) of this Regulation which can be operated from above the bulkhead deck shall have their controls at their place of operation clearly marked and provided with means to indicate whether they are open or closed.

Regulation 19. Stability Information for Passenger Ships and Cargo Ships⁵

- (a) Every passenger ship and cargo ship shall be inclined upon its completion and the elements of its stability determined. The master shall be supplied with such reliable information as is necessary to enable him by rapid and simple processes to obtain accurate guidance as to the stability of the ship under varying conditions of service, and a copy shall be furnished to the Administration.
- (b) Where any alterations are made to a ship so as to materially affect the stability information supplied to the master, amended stability information shall be provided. If necessary the ship shall be re-inclined.
- (c) The Administration may allow the inclining test of an individual ship to be dispensed with provided basic stability data are available from the inclining test of a sister ship and it is shown to the satisfaction of the Administration that reliable stability information for the exempted ship can be obtained from such basic data.
- (d) The Administration may also allow the inclining test of an individual ship or class of ships, especially designed for the carriage of liquids or ore in bulk, to be dispensed with when reference to existing data for similar ships clearly indicates that due to the ship's proportions and arrangements more than sufficient metacentric height will be available in all probable loading conditions.

Regulation 20. Damage Control Plans

There shall be permanently exhibited, for the guidance of the officer in charge of the ship, plans showing clearly for each deck and hold the boundaries of the watertight compartments, the openings therein with the means of closure and position of any controls thereof, and the arrangements for the correction of any list due to flooding. In addition, booklets containing the aforementioned information shall be made available to the officers of the ship.

Regulation 21. Marking, Periodical Operation and Inspection of Watertight Doors, etc.

- (a) This Regulation applies to new and existing ships.
- (b) Drills for the operating of watertight doors, sidescuttles, valves and closing mechanisms of scuppers, ash-shoots and rubbish-shoots shall take place weekly. In ships in which the voyage exceeds one week in duration a complete drill shall be held before leaving port, and others thereafter at least once a week during the voyage. In all ships all watertight power doors and hinged doors, in main transverse bulkheads, in use at sea, shall be operated daily.

⁵ Reference is made to the Recommendation on Intact Stability for Passenger and Cargo Ships under 100 metres in length, adopted by the Organization by Resolution A. 167(ES.IV) and Amendments to this Recommendation, adopted by the Organization by Resolution A.206(VH).

- (c) (i) The watertight doors and all mechanisms and indicators connected therewith, all valves the closing of which is necessary to make a compartment watertight, and all valves the operation of which is necessary for damage control cross connexions shall be periodically inspected at sea at least once a week.
- (ii) Such valves, doors and mechanisms shall be suitably marked to ensure that they may be properly used to provide maximum safety.

Regulation 22. Entries in Log

- (a) This Regulation applies to new and existing ships.
- (b) Hinged doors, portable plates, sidescuttles, gangway, cargo and coaling ports and other openings, which are required by these Regulations to be kept closed during navigation, shall be closed before the ship leaves port. The time of closing and the time of opening (if permissible under these Regulations) shall be recorded in such log book as may be prescribed by the Administration.
- (c) A record of all drills and inspections required by Regulation 21 of this Chapter shall be entered in the log book with an explicit record of any defects which may be disclosed.

PART C MACHINERY AND ELECTRICAL INSTALLATIONS⁶

(Part C applies to passenger ships and cargo ships)

Regulation 23. General

- (a) Electrical installations in passenger ships shall be such that:
 - (i) services essential for safety will be maintained under various emergency conditions; and
 - (ii) the safety of passengers, crew and ship from electrical hazards will be assured.
- (b) Cargo ships shall comply with Regulations 26, 27, 28, 29, 30 and 32 of this Chapter.

Regulation 24. Main Source of Electrical Power in Passenger Ships

- (a) Every passenger ship, the electrical power of which constitutes the only means of maintaining the auxiliary services indispensable for the propulsion and the safety of the ship, shall be provided with at least two main generating sets. The power of these sets shall be such that it shall still be possible to ensure the functioning of the services referred to in sub-paragraph (a)(i) of Regulation 23 of this Chapter in the event of any one of these generating sets being stopped.
- (b) In a passenger ship where there is only one main generating station, the main switchboard shall be located in the same main fire zone. Where there is more than one main generating station, it is permissible to have only one main switchboard.

⁶ Reference is made to the Recommendation on Safety Measures for Periodically Unattended Machinery Spaces of Cargo Ships additional to those normally considered necessary for an Attended Machinery Space, adopted by the Organization by Resolution A.211 (VI1).

Regulation 25. Emergency Source of Electrical Power in Passenger Ships

- (a) There shall be above the bulkhead deck and outside the machinery casings a self-contained emergency source of electrical power. Its location in relation to the main source or sources of electrical power shall be such as to ensure to the satisfaction of the Administration that a fire or other casualty to the machinery space as defined in paragraph (h) of Regulation 2 of this Chapter will not interfere with the supply or distribution of emergency power. It shall not be forward of the collision bulkhead.
- (b) The power available shall be sufficient to supply all those services that are, in the opinion of the Administration, necessary for the safety of the passengers and the crew in an emergency, due regard being paid to such services as may have to be operated simultaneously. Special consideration shall be given to emergency lighting at every boat station on deck and oversides, in all alleyways, stairways and exits, in the machinery spaces and in the control stations as defined in paragraph (r) of Regulation 3 of Chapter II-2, to the sprinkler pump, to navigation lights, and to the daylight signalling lamp if operated from the main source of power. The power shall be adequate for a period of 36 hours, except that, in the case of ships engaged regularly on voyages of short duration, the Administration may accept a lesser supply if satisfied that the same standard of safety would be attained.
- (c) The emergency source of power may be either:
- (i) a generator driven by a suitable prime-mover with an independent fuel supply and with approved starting arrangements; the fuel used shall have a flashpoint of not less than 43deg.C (110deg.F); or
 - (ii) an accumulator (storage) battery capable of carrying the emergency load without recharging or excessive voltage drop.
- (d) (i) Where the emergency source of power is a generator there shall be provided a temporary source of emergency power consisting of an accumulator battery of sufficient capacity:
- (1) to supply emergency lighting continuously for half an hour;
 - (2) to close the watertight doors (if electrically operated) but not necessarily to close them all simultaneously;
 - (3) to operate the indicators (if electrically operated) which show whether power-operated watertight doors are open or closed; and
 - (4) to operate the sound signals (if electrically operated) which give warning that power-operated watertight doors are about to close.
- The arrangements shall be such that the temporary source of emergency power will come into operation automatically in the event of failure of the main electrical supply.
- (ii) Where the emergency source of power is an accumulator battery, arrangements shall be made to ensure that emergency lighting will automatically come into operation in the event of failure of the main lighting supply.
- (e) An indicator shall be mounted in the machinery space, preferably on the main switchboard, to indicate when any accumulator battery fitted in accordance with this Regulation is being discharged.

- (f) (i) The emergency switchboard shall be installed as near as is practicable to the emergency source of power.
 - (ii) Where the emergency source of power is a generator, the emergency switchboard shall be located in the same space as the emergency source of power, unless the operation of the emergency switchboard would thereby be impaired.
 - (iii) No accumulator battery fitted in accordance with this Regulation shall be installed in the same space as the emergency switchboard.
 - (iv) The Administration may permit the emergency switchboard to be supplied from the main switchboard in normal operation.
- (g) Arrangements shall be such that the complete emergency installation will function when the ship is inclined 22½ degrees and/or when the trim of the ship is 10 degrees.
- (h) Provision shall be made for the periodic testing of the emergency source of power and the temporary source of power, if provided, which shall include the testing of automatic arrangements.

Regulation 26. Emergency Source of Electrical Power in Cargo Ships

- (a) Cargo ships of 5,000 tons gross tonnage and upwards
- (i) In cargo ships of 5,000 tons gross tonnage and upwards there shall be a self-contained emergency source of power, located to the satisfaction of the Administration above the uppermost continuous deck and outside the machinery casings, to ensure its functioning in the event of fire or other casualty causing failure to the main electrical installation.
 - (ii) The power available shall be sufficient to supply all those services which are, in the opinion of the Administration, necessary for the safety of all on board in an emergency, due regard being paid to such services as may have to be operated simultaneously. Special consideration shall be given to:
 - (1) emergency lighting at every boat station on deck and oversides, in all alleyways, stairways and exits, in the main machinery space and main generating set space, on the navigating bridge and in the chartroom;
 - (2) the general alarm; and
 - (3) navigation lights if solely electric, and the daylight signalling lamp if operated by the main source of electrical power.The power shall be adequate for a period of 6 hours.
 - (iii) The emergency source of power may be either:
 - (1) an accumulator (storage) battery capable of carrying the emergency load without recharging or excessive voltage drop; or
 - (2) a generator driven by a suitable prime-mover with an independent fuel supply and with starting arrangements to the satisfaction of the Administration. The fuel used shall have a flashpoint of not less than 43°C (110°F).

- (iv) Arrangements shall be such that the complete emergency installation will function when the ship is inclined 22½ degrees and/or when the trim of the ship is 10 degrees.
 - (v) Provision shall be made for the periodic testing of the complete emergency installation.
- (b) Cargo ships of less than 5,000 tons gross tonnage
- (i) In cargo ships of less than 5,000 tons gross tonnage there shall be a self-contained emergency source of power located to the satisfaction of the Administration, and capable of supplying the illumination at launching stations and stowage positions of survival craft prescribed in sub-paragraphs (a)(ii), (b)(ii) and (b)(iii) of Regulation 19 of Chapter III, and in addition such other services as the Administration may require, due regard being paid to Regulation 38 of Chapter III.
 - (ii) The power available shall be adequate for a period of at least 3 hours.
 - (iii) These ships shall also be subject to sub-paragraphs (iii), (iv), and (v) of paragraph (a) of this Regulation.

Regulation 27. Precautions Against Shock, Fire and Other Hazards of Electrical Origin

(a) Passenger ships and cargo ships

- (i) (1) All exposed metal parts of electrical machines or equipment which are not intended to be "live" but are liable to become "live" under fault conditions, shall be earthed (grounded); and all electrical apparatus shall be so constructed and so installed that danger of injury in ordinary handling shall not exist.
- (2) Metal frames of all portable electric lamps, tools and similar apparatus, supplied as ship's equipment and rated in excess of a safety voltage to be prescribed by the Administration shall be earthed (grounded) through a suitable conductor, unless equivalent provisions are made such as by double insulation or by an isolating transformer. The Administration may require additional special precautions for electric lamps, tools or similar apparatus for use in damp spaces.
- (ii) Main and emergency switchboards shall be so arranged as to give easy access back and front, without danger to attendants. The sides and backs and, where necessary, the fronts of switchboards shall be suitably guarded. There shall be non-conducting mats or gratings front and rear where necessary. Exposed current-carrying parts at voltages to earth (ground) exceeding a voltage to be specified by the Administration shall not be installed on the face of any switchboard or control panel.
- (iii) (1) Where the hull return system of distribution is used, special precautions shall be taken to the satisfaction of the Administration.
- (2) Hull return shall not be used in tankers.
- (iv) (1) All metal sheaths and armour of cables shall be electrically continuous and shall be earthed (grounded).
- (2) Where the cables are neither sheathed nor armoured and there might be a risk of fire in the event of an electrical fault, precautions shall be required by the Administration.

- (v) Lighting fittings shall be arranged to prevent temperature rises that would be injurious to the wiring, and to prevent surrounding material from becoming excessively hot.
 - (vi) Wiring shall be supported in such a manner as to avoid chafing or other injury.
 - (vii) Each separate circuit shall be protected against short circuit. Each separate circuit shall also be protected against overload, except in accordance with Regulation 30 of this Chapter or where the Administration grants an exemption. The current-carrying capacity of each circuit shall be permanently indicated, together with the rating or setting of the appropriate overload protective device.
 - (viii) Accumulator batteries shall be suitably housed, and compartments used primarily for their accommodation shall be properly constructed and efficiently ventilated.
- (b) *Passenger ships only*
- (i) Distribution systems shall be so arranged that fire in any main fire zone will not interfere with essential services in any other main fire zone. This requirement will be met if main and emergency feeders passing through any zone are separated both vertically and horizontally as widely as is practicable.
 - (ii) Electric cables shall be of a flame retarding type to the satisfaction of the Administration. The Administration may require additional safeguards for electric cables in particular spaces of the ship with a view to the prevention of fire or explosion.
 - (iii) In spaces where inflammable mixtures are liable to collect, no electrical equipment shall be installed unless it is of a type which will not ignite the mixture concerned, such as flameproof (explosion proof) equipment.
 - (iv) A lighting circuit in a bunker or hold shall be provided with an isolating switch outside the space.
 - (v) Joints in all conductors except for low voltage communication circuits shall be made only in junction or outlet boxes. All such boxes or wiring devices shall be so constructed as to prevent the spread of fire from the box or device. Where splicing is employed it shall only be by an approved method such that it retains the original mechanical and electrical properties of the cable.
 - (vi) Wiring systems for interior communications essential for safety and for emergency alarm systems shall be arranged to avoid galleys, machinery spaces and other enclosed spaces having a high risk of fire except in so far as it is necessary to provide communication or to give alarm within those spaces. In the case of ships the construction and small size of which do not permit of compliance with these requirements, measures satisfactory to the Administration shall be taken to ensure efficient protection for these wiring systems where they pass through galleys, machinery spaces and other enclosed spaces having a high risk of fire.
- (c) *Cargo ships only.* Devices liable to arc shall not be installed in any compartment assigned principally to accumulator batteries unless the devices are flameproof (explosion proof).

Regulation 28. Means of Going Astern

- (a) *Passenger ships and cargo ships.* Ships shall have sufficient power for going astern to secure proper control of the ship in all normal circumstances.

- (b) *Passenger ships only* The ability of the machinery to reverse the direction of thrust of the propeller in sufficient time, under normal manoeuvring conditions, and so to bring the ship to rest from maximum ahead service speed shall be demonstrated at the initial survey.

Regulation 29. Steering Gear⁷

(a) *Passenger ships and cargo ships*

- (i) Ships shall be provided with a main steering gear and an auxiliary steering gear to the satisfaction of the Administration.
- (ii) The main steering gear shall be of adequate strength and sufficient to steer the ship at maximum service speed. The main steering gear and rudder stock shall be so designed that they are not damaged at maximum astern speed.
- (iii) The auxiliary steering gear shall be of adequate strength and sufficient to steer the ship at navigable speed and capable of being brought speedily into action in an emergency.
- (iv) The exact position of the rudder, if power operated, shall be indicated at the principal steering station.

(b) *Passenger ships only*

- (i) The main steering gear shall be capable of putting the rudder over from 35 degrees on one side to 35 degrees on the other side with the ship running ahead at maximum service speed. The rudder shall be capable of being put over from 35 degrees on either side to 30 degrees on the other side in 28 seconds at maximum service speed.
- (ii) The auxiliary steering gear shall be operated by power in any case in which the Administration would require a rudder stock of over 228.6 millimetres (9 inches) diameter in way of the tiller.
- (iii) Where main steering gear power units and their connexions are fitted in duplicate to the satisfaction of the Administration, and each power unit enables the steering gear to meet the requirements of sub-paragraph (i) of this paragraph, no auxiliary steering gear need be required.
- (iv) Where the Administration would require a rudder stock with a diameter in way of the tiller exceeding 228.6 millimetres (9 inches) there shall be provided an alternative steering station located to the satisfaction of the Administration. The remote steering control systems from the principal and alternative steering stations shall be so arranged to the satisfaction of the Administration that failure of either system would not result in inability to steer the ship by means of the other system.
- (v) means satisfactory to the Administration shall be provided to enable orders to be transmitted from the bridge to the alternative steering station.

(c) *Cargo ships only*

⁷ Reference is made to the Recommendation on Steering Gear for Large Ships, adopted by the Organization by Resolution A.2KKV(II).

- (i) The auxiliary steering gear shall be operated by power in any case in which the Administration would require a rudder stock of over 355.6 millimetres (14 inches) diameter in way of the tiller.
- (ii) Where power-operated steering gear units and connexions are fitted in duplicate to the satisfaction of the Administration, and each unit complies with sub-paragraph (iii) of paragraph (a) of this Regulation, no auxiliary steering gear need be required, provided that the duplicate units and connexions operating together comply with sub-paragraph (ii) of paragraph (a) of this Regulation.

Regulation 30. Electric and Electrohydraulic Steering Gear⁸

- (a) *Passenger ships and cargo ships.* Indicators for running indication of the motors of electric and electrohydraulic steering gear shall be installed in a suitable location to the satisfaction of the Administration.
- (b) *All passenger ships (irrespective of tonnage) and cargo ships of 5,000 tons gross tonnage and upwards.*
 - (i) Electric and electrohydraulic steering gear shall be served by two circuits fed from the main switchboard. One of the circuits may pass through the emergency switchboard, if provided. Each circuit shall have adequate capacity for supplying all the motors which are normally connected to it and which operate simultaneously. If transfer arrangements are provided in the steering gear room to permit either circuit to supply any motor or combination of motors, the capacity of each circuit shall be adequate for the most severe load condition. The circuits shall be separated throughout their length as widely as is practicable.
 - (ii) Short circuit protection only shall be provided for these circuits and motors.
- (c) *Cargo ships of less than 5,000 tons gross tonnage*
 - (i) Cargo ships in which electrical power is the sole source of power for both main and auxiliary steering gear shall comply with sub-paragraphs (i) and (ii) of paragraph (b) of this Regulation, except that if the auxiliary steering gear is powered by a motor primarily intended for other services, paragraph (b)(ii) may be waived, provided that the Administration is satisfied with the protection arrangements.
 - (ii) Short circuit protection only shall be provided for motors and power circuits of electrically or electrohydraulically operated main steering gear.

Regulation 31. Location of Emergency Installations in Passenger Ships

The emergency source of electrical power, emergency fire pumps, emergency bilge pumps, batteries of carbon dioxide bottles for fire extinguishing purposes and other emergency installations which are essential for the safety of the ship shall not be installed in a passenger ship forward of the collision bulkhead.

Regulation 32. Communication Between Bridge and Engine Room

Ships shall be fitted with two means of communicating orders from the bridge to the engine room. One means shall be an engine room telegraph.

⁸ Reference is made to the Recommendation on Steering Gear for Large Ships, adopted by the Organization by Resolution A.210(VH).

CHAPTER II-2

CONSTRUCTION - FIRE PROTECTION, FIRE DETECTION AND FIRE EXTINCTION

PART A GENERAL⁹

Regulation 1. Application

- (a) For the purpose of this Chapter:
- (i) A new passenger ship is a passenger ship the keel of which is laid or which is at a similar stage of construction on or after the date of coming into force of the present Convention, or a cargo ship which is converted to a passenger ship on or after that date, all other passenger ships being considered as existing ships.
 - (ii) A new cargo ship is a cargo ship the keel of which is laid or which is at a similar stage of construction on or after the date of coming into force of the present Convention.
 - (iii) A ship which undergoes repairs, alterations, modifications and outfitting related thereto shall continue to comply with at least the requirements previously applicable to the ship. An existing ship in such a case shall not as a rule comply to a lesser extent with the requirements for a new ship than it did before. Repairs, alterations and modifications of a major character and outfitting related thereto should meet the requirements for a new ship in so far as the Administration deems reasonable and practicable.
- (b) Unless expressly provided otherwise:
- (i) Regulations 4 to 16 of Part A of this Chapter apply to new ships.
 - (ii) Part B of this Chapter applies to new passenger ships carrying more than 36 passengers.
 - (iii) Part C of this Chapter applies to new passenger ships carrying not more than 36 passengers.
 - (iv) Part D of this Chapter applies to new cargo ships.
 - (v) Part E of this Chapter applies to new tankers.
- (c) (i) Part F of this Chapter applies to existing passenger ships carrying more than 36 passengers.
- (ii) Existing passenger ships carrying not more than 36 passengers and existing cargo ships shall comply with the following:
- (1) For ships the keels of which were laid or which were at a similar stage of construction on or after the date of coming into force of the International Convention for the Safety

⁹ Reference is made to Recommendation on Safety Measures for Periodically Unattended Machinery Spaces of Cargo Ships additional to those normally considered necessary for an Attended Machinery Space, adopted by the Organization by Resolution A.211(VII).

of Life at Sea, 1960, the Administration shall ensure that the requirements which were applied under Chapter II of that Convention to new ships as defined in that Chapter are complied with;

- (2) For ships the keels of which were laid or which were at a similar stage of construction on or after the date of coming into force of the International Convention for the Safety of Life at Sea, 1948, but before the date of coming into force of the International Convention for the Safety of Life at Sea, 1960, the Administration shall ensure that the requirements which were applied under Chapter II of the 1948 Convention to new ships as defined in that Chapter are complied with;
 - (3) For ships the keels of which were laid or which were at a similar stage of construction before the date of coming into force of the International Convention for the Safety of Life at Sea, 1948, the Administration shall ensure that the requirements which were applied under Chapter II of that Convention to existing ships as defined in that Chapter are complied with.
- (d) For any existing ship as defined in the present Convention the Administration, in addition to applying the requirements of sub-paragraph (c)(i) of this Regulation, shall decide which of the requirements of this Chapter not contained in Chapter II of the 1948 and 1960 Conventions shall be applied.
- (e) The Administration may, if it considers that the sheltered nature and conditions of the voyage are such as to render the application of any specific requirements of this Chapter unreasonable or unnecessary, exempt from those requirements individual ships or classes of ships belonging to its country which, in the course of their voyage, do not proceed more than 20 miles from the nearest land.
- (f) In the case of passenger ships which are employed in special trades for the carriage of large numbers of special trade passengers, such as the pilgrim trade, the Administration, if satisfied that it is impracticable to enforce compliance with the requirements of this Chapter, may exempt such ships, when they belong to its country, from those requirements, provided that they comply fully with the provisions of:
- (i) the Rules annexed to the Special Trade Passenger Ships Agreement, 1971, and
 - (ii) the Rules annexed to the Protocol on Space Requirements for Special Trade Passenger Ships, 1973, when it comes into force.

Regulation 2. Basic Principles

The purpose of this Chapter is to require the fullest practicable degree of fire protection, fire detection and fire extinction in ships. The following basic principles underlie the Regulations in this Chapter and are embodied in the Regulations as appropriate, having regard to the type of ships and the potential fire hazard involved:

- (a) division of ship into main vertical zones by thermal and structural boundaries;
- (b) separation of accommodation spaces from the remainder of the ship by thermal and structural boundaries;
- (c) restricted use of combustible materials;
- (d) detection of any fire in the zone of origin;

- (e) containment and extinction of any fire in the space of origin;
- (f) protection of means of escape or access for fire fighting;
- (g) ready availability of fire-extinguishing appliances;
- (h) minimization of possibility of ignition of inflammable¹⁰ cargo vapour.

Regulation 3. Definitions

For the purpose of this Chapter, unless expressly provided otherwise:

- (a) "Non-combustible material" means a material which neither burns nor gives off inflammable vapours in sufficient quantity for self-ignition when heated to approximately 750°C (1,382°F) this being determined to the satisfaction of the Administration by an established test procedure.¹¹ Any other material is a combustible material.
- (b) "A Standard Fire Test" is one in which specimens of the relevant bulkheads or decks are exposed in a test furnace to temperatures corresponding approximately to the standard time-temperature curve. The specimen shall have an exposed surface of not less than 4.65 square metres (50 square feet) and height (or length of deck) of 2.44 metres (8 feet) resembling as closely as possible the intended construction and including where appropriate at least one joint. The standard time-temperature curve is defined by a smooth curve drawn through the following points:
 - at the end of the first 5 minutes - 538°C (1,000°F)
 - at the end of the first 10 minutes - 704°C (1,300°F)
 - at the end of the first 30 minutes - 843°C (1,550°F)
 - at the end of the first 60 minutes - 927°C (1,700°F)
- (c) "'A' Class Division" are those divisions formed by bulkheads and decks which comply with the following:
 - (i) they shall be constructed of steel or other equivalent material;
 - (ii) they shall be suitably stiffened;
 - (iii) they shall be so constructed as to be capable of preventing the passage of smoke and flame to the end of the one-hour standard fire test;
 - (iv) they shall be insulated with approved non-combustible materials such that the average temperature of the unexposed side will not rise more than 139°C (250°F) above the original temperature, nor will the temperature, at any one point, including any joint, rise more than 180°C (325°F) above the original temperature, within the time listed below:

¹⁰ "Inflammable" has the same meaning as "flammable".

¹¹ Reference is made to Recommendation on Test Method for Qualifying Marine Construction Materials as Non-Combustible, adopted by the Organization by Resolution A.270(VHI).

- Class "A-60", 60 minutes
- Class "A-30", 30 minutes
- Class "A-15", 15 minutes
- Class "A-0", 0 minutes

- (v) the Administration may require a test of a prototype bulkhead or deck to ensure that it meets the above requirements for integrity and temperature rise.¹²
- (d) "'B' Class Divisions" are those divisions formed by bulkheads, decks, ceilings or linings which comply with the following:
- (i) they shall be so constructed as to be capable of preventing the passage of flame to the end of the first one-half hour of the standard fire test;
 - (ii) they shall have an insulation value such that the average temperature of the unexposed side will not rise more than 139°C (250°F) above the original temperature, nor will the temperature at any one point, including any joint, rise more than 225°C (405°F) above the original temperature, within the time listed below:
 - Class "B-15", 15 minutes
 - Class "B-0", 0 minutes
 - (iii) they shall be constructed of approved non-combustible materials and all materials entering into the construction and erection of 'B' Class divisions shall be non-combustible, except where in accordance with Parts C and D of this Chapter the use of combustible material is not precluded, in which case it shall comply with the temperature rise limitation specified in sub-paragraph (ii) of this paragraph up to the end of the first one-half hour of the standard fire test;
 - (iv) the Administration may require a test of a prototype division to ensure that it meets the above requirements for integrity and temperature rise.
- (e) "'C' Class Divisions" shall be constructed of approved non-combustible materials. They need meet no requirements relative to the passage of smoke and flame nor the limiting of temperature rise.
- (f) "Continuous 'B' Class Ceilings or Linings" are those 'B' Class ceilings or linings which terminate only at an 'A' or 'B' Class division.
- (g) "*Steel or Other Equivalent Material*". Where the words "steel or other equivalent material" occur, "equivalent material" means any material which, by itself or due to insulation provided, has structural and integrity properties equivalent to steel at the end of the applicable fire exposure to the standard fire test (e.g. aluminium alloy with appropriate insulation).
- (h) "Low Flame Spread" means that the surface thus described will adequately restrict the spread of flame, this being determined to the satisfaction of the Administration by an established test procedure.

¹² Reference is made to Recommendation for Fire Test Procedures for 'A' and 'B' Class Divisions, adopted by the Organization by Resolutions A.163(ES.IV) and A.215(VII).

- (i) "Main Vertical Zones" are those sections into which the hull, superstructure, and deckhouses are divided by 'A' Class divisions, the mean length of which on any one deck does not in general exceed 40 metres (131 feet).
- (j) "Accommodation Spaces" are those used for public spaces, corridors, lavatories, cabins, offices, crew quarters, barber shops, isolated pantries and lockers and similar spaces.
- (k) "Public Spaces" are those portions of the accommodation which are used for halls, dining rooms, lounges and similar permanently enclosed spaces.
- (l) "Service Spaces" are those used for galleys, main pantries, stores (except isolated pantries and lockers), mail and specie rooms, workshops other than those forming part of machinery spaces, and similar spaces and trunks to such spaces.
- (m) "Cargo Spaces" are all spaces used for cargo (including cargo oil tanks) and trunks to such spaces.
- (n) "Special Category Spaces" are those enclosed spaces above or below the bulkhead deck intended for the carriage of motor vehicles with fuel in their tanks for their own propulsion, into and from which such vehicles can be driven and to which passengers have access.
- (o) "Machinery Spaces of Category A" are all spaces which contain:
 - (i) internal combustion type machinery used either for main propulsion purposes, or for other purposes where such machinery has in the aggregate a total power output of not less than 373 kW, or
 - (ii) any oil-fired boiler or oil fuel unit; and trunks to such spaces.
- (p) "Machinery Spaces" are all machinery spaces of Category A and all other spaces containing propelling machinery, boilers, oil fuel units, steam and internal combustion engines, generators and major electrical machinery, oil filling stations, refrigerating, stabilizing, ventilation and air conditioning machinery, and similar spaces; and trunks to such spaces.
- (q) "Oil Fuel Unit" means the equipment used for the preparation of oil fuel for delivery to an oil-fired boiler, or equipment used for the preparation for delivery of heated oil to an internal combustion engine, and includes any oil pressure pumps, filters and heaters dealing with oil at a pressure more than 1.8 kilogrammes per square centimetre (25 pounds per square inch) gauge.
- (r) "Control Stations" are those spaces in which the ship's radio or main navigating equipment or the emergency source of power is located or where the fire recording or fire control equipment is centralized.
- (s) "Rooms containing Furniture and Furnishings of Restricted Fire Risk" are, for the purpose of Regulation 20 of this Chapter, those rooms containing furniture and furnishings of restricted fire risk (whether cabins, public spaces, offices or other types of accommodation) in which:
 - (i) all case furniture such as desks, wardrobes, dressing tables, bureaux, dressers, is constructed entirely of approved non-combustible materials, except that a combustible veneer not exceeding 2 millimetres ($\frac{1}{12}$ inch) may be used on the working surface of such articles;

- (ii) all free-standing furniture such as chairs, sofas, tables, is constructed with frames of non-combustible materials;
 - (iii) all draperies, curtains and other suspended textile materials have, to the satisfaction of the Administration, qualities of resistance to the propagation of flame not inferior to those of wool weighing 0.8 kilogrammes per square metre (24 ounces per square yard);
 - (iv) all floor coverings have, to the satisfaction of the Administration, qualities of resistance to the propagation of flame not inferior to those of an equivalent woollen material used for the same purpose; and
 - (v) all exposed surfaces of bulkheads, linings and ceilings have low flame-spread characteristics.
- (t) "Bulkhead deck" is the uppermost deck up to which the transverse watertight bulkheads are carried.
- (u) "Deadweight" is the difference in metric tons between the displacement of a ship in water of a specific gravity of 1.025 at the load water line corresponding to the assigned summer freeboard and the lightweight of the ship.
- (v) "Lightweight" is the displacement of a ship in metric tons without cargo, fuel, lubricating oil, ballast water, fresh water and feedwater in tanks, consumable stores, together with passengers, and crew and their effects.
- (w) "Combination carrier" is a tanker designed to carry oil or alternatively solid cargoes in bulk.

Regulation 4. Fire Control Plans

There shall be permanently exhibited in all new and existing ships for the guidance of the ship's officers general arrangement plans showing clearly for each deck the control stations, the various fire sections enclosed by 'A' Class divisions, the sections enclosed by 'B' Class divisions (if any), together with particulars of the fire alarms, detecting systems, the sprinkler installation (if any), the fire extinguishing appliances, means of access to different compartments, decks, etc. and the ventilating system including particulars of the fan control positions, the position of dampers and identification numbers of the ventilating fans serving each section. Alternatively, at the discretion of the Administration, the aforementioned details may be set out in a booklet, a copy of which shall be supplied to each officer, and one copy at all times shall be available on board in an accessible position. Plans and booklets shall be kept up to date, any alterations being recorded thereon as soon as practicable. Description in such plans and booklets shall be in the national language. If the language is neither English nor French, a translation into one of those languages shall be included. In addition, instructions concerning the maintenance and operation of all the equipment and installations on board for the fighting and containment of fire shall be kept under one cover, readily available in an accessible position.

Regulation 5. Fire Pumps, Fire Mains, Hydrants and Hoses

- (a) *Total capacity of fire pumps*
- (i) In a passenger ship, the required fire pumps shall be capable of delivering for fire-fighting purposes a quantity of water, at the appropriate pressure prescribed below, not less than two-thirds of the quantity required to be dealt with by the bilge pumps when employed for bilge pumping.

- (ii) In a cargo ship, the required fire pumps, other than the emergency pump (if any), shall be capable of delivering for fire-fighting purposes a quantity of water, at the appropriate pressure prescribed, not less than four-thirds of the quantity required under Regulation 18 of Chapter II-1 to be dealt with by each of the independent bilge pumps in a passenger ship of the same dimensions when employed on bilge pumping, provided that in no cargo ship need the total required capacity of the fire pumps exceed 180 cubic metres per hour.

(b) *Fire pumps*

- (i) The fire pumps shall be independently driven. Sanitary, ballast, bilge or general service pumps may be accepted as fire pumps, provided that they are not normally used for pumping oil and that if they are subject to occasional duty for the transfer or pumping of fuel oil, suitable change-over arrangements are fitted.
- (ii) (1) In passenger ships carrying more than 36 passengers, each of the required fire pumps shall have a capacity not less than 80 per cent of the total required capacity divided by the minimum number of required fire pumps and each such pump shall in any event be capable of delivering at least the two required jets of water. These fire pumps shall be capable of supplying the fire main system under the required conditions.

Where more pumps than the minimum of required pumps are installed the capacity of such additional pumps shall be to the satisfaction of the Administration.

- (2) In all other types of ships, each of the required fire pumps (other than any emergency pump required by Regulation 52 of this Chapter) shall have a capacity not less than 80 per cent of the total required capacity divided by the number of required fire pumps, and shall in any event be capable of delivering at least the two required jets of water. These fire pumps shall be capable of supplying the fire main system under the required conditions.

Where more pumps than required are installed their capacity shall be to the satisfaction of the Administration.

- (iii) Relief valves shall be provided in conjunction with all fire pumps if the pumps are capable of developing a pressure exceeding the design pressure of the water service pipes, hydrants and hoses. These valves shall be so placed and adjusted as to prevent excessive pressure in any part of the fire main system.

(c) *Pressure in the fire main*

- (i) The diameter of the fire main and water service pipes shall be sufficient for the effective distribution of the maximum required discharge from two fire pumps operating simultaneously, except that in the case of cargo ships the diameter need only be sufficient for the discharge of 140 cubic metres per hour.
- (ii) With the two pumps simultaneously delivering through nozzles specified in paragraph (g) of this Regulation the quantity of water specified in sub-paragraph (i) of this paragraph, through any adjacent hydrants, the following minimum pressures shall be maintained at all hydrants:

<i>Passenger Ships</i>	<i>Minimum Pressure</i>
4,000 tons gross tonnage and upwards	3.2 kilogrammes per square centimeter (45 pounds per square inch)
1,000 tons gross upwards but under 4000 tons gross tonnage	2.8 kilogrammes per square centimeter (40 pounds per square inch)
Under 1,000 tons gross tonnage	To the satisfaction of the Administration

<i>Cargo Ships</i>	<i>Minimum Pressure</i>
6,000 tons gross tonnage and upwards	2.8 kilogrammes per square centimeter (40 pounds per square inch)
1,000 tons gross tonnage and upwards but under 6,000 tons gross tonnage	2.6 kilogrammes per square centimeter (37 pounds per square inch)
Under 1,000 tons gross tonnage	To the satisfaction of the Administration

- (d) *Number and position of hydrants.* The number and position of the hydrants shall be such that at least two jets of water not emanating from the same hydrant, one of which shall be from a single length of hose, may reach any part of the ship normally accessible to the passengers or crew while the ship is being navigated.
- (e) *Pipes and hydrants*
- (i) Materials readily rendered ineffective by heat shall not be used for fire mains and hydrants unless adequately protected. The pipes and hydrants shall be so placed that the fire hoses may be easily coupled to them. In ships where deck cargo may be carried, the positions of the hydrants shall be such that they are always readily accessible and the pipe shall be arranged as far as practicable to avoid risk of damage by such cargo. Unless there is provided one hose and nozzle for each hydrant in the ship, there shall be complete interchangeability of hose couplings and nozzles.
- (ii) A cock or valve shall be fitted to serve each fire hose so that any fire hose may be removed while the fire pumps are at work.
- (f) *Fire hoses.* Fire hoses shall be of material approved by the Administration and sufficient in length to project a jet of water to any of the spaces in which they may be required to be used. Their maximum length shall be to the satisfaction of the Administration. Each hose shall be provided with a nozzle and the necessary couplings. Hoses specified in this Chapter as "fire hoses" shall together with any necessary fittings and tools be kept ready for use in conspicuous positions near the water service hydrants or connexions. Additionally in interior locations in passenger ships carrying more than 36 passengers, fire hoses shall be connected to the hydrants at all times.
- (i) *Nozzles.* For the purposes of this Chapter, standard nozzle sizes shall be 12 millimetres ($\frac{1}{2}$ inch), 16 millimetres ($\frac{5}{8}$ inch) and 19 millimetres ($\frac{3}{4}$ inch) or as near thereto as possible. Larger diameter nozzles may be permitted at the discretion of the Administration.

- (ii) For accommodation and service spaces, a nozzle size greater than 12 millimetres ($\frac{1}{2}$ inch) need not be used.
- (iii) For machinery spaces and exterior locations, the nozzle size shall be such as to obtain the maximum discharge possible from two jets at the pressure mentioned in paragraph (c) of this Regulation from the smallest pump, provided that a nozzle size greater than 19 millimetres ($\frac{3}{4}$ inch) need not be used.
- (iv) For machinery spaces or in similar spaces where the risk of spillage of oil exists, the nozzles shall be suitable for spraying water on oil or alternatively shall be of a dual purpose type.

(g) *International shore connexion*

Standard dimensions of flanges for the international shore connexion required in this Chapter to be installed in the ship shall be in accordance with the following table:

<i>Description</i>	<i>Dimension</i>
Outside diameter	178 millimetres (7 inches)
Inner diameter	64 millimetres (2 $\frac{1}{2}$ inches)
Bolt circle diameter	132 millimetres (5 $\frac{1}{4}$ inches)
Slots in flange	4 holes, 19 millimetres ($\frac{3}{4}$ inch) in diameter equidistantly placed on a bolt circle of the above diameter, slotted to the flange periphery
Flange thickness	14.5 millimetres (9/16 inch) minimum
Bolts and nuts	4, each of 16 millimetres (5/8 inch) diameter, 50 millimetres (2 inches) in length

The connexion shall be constructed of material suitable for 10.5 kilogrammes per square centimetre (150 pounds per square inch) service. The flange shall have a flat face on one side and the other shall have permanently attached thereto a coupling that will fit the ship's hydrant and hose. The connexion shall be kept aboard the ship together with a gasket of any material suitable for 10.5 kilogrammes per square centimetre (150 pounds per square inch) service, together with four 16 millimetre (5/8 inch) bolts, 50 millimetres (2 inches) in length and eight washers.

Regulation 6. Miscellaneous Items

- (a) Electric radiators, if used, shall be fixed in position and so constructed as to reduce fire risks to a minimum. No such radiators shall be fitted with an element so exposed that clothing, curtains, or other similar materials can be scorched or set on fire by heat from the element.
- (b) Cellulose-nitrate based films shall not be used for cinematograph installations.

Regulation 7. Fire Extinguishers

- (a) All fire extinguishers shall be of approved types and designs.
 - (i) The capacity of required portable fluid extinguishers shall be not more than 13.5 litres (3 gallons) and not less than 9 litres (2 gallons). Other extinguishers shall not be in excess of the equivalent portability of the 13.5 litre (3 gallons) fluid extinguisher and shall not be less than the fire-extinguishing equivalent of a 9 litre (2 gallons) fluid extinguisher.
 - (ii) The Administration shall determine the equivalents of fire extinguishers.

- (b) Spare charges shall be provided in accordance with requirements to be specified by the Administration.
- (c) Fire extinguishers containing an extinguishing medium which, in the opinion of the Administration, either by itself or under expected conditions of use gives off toxic gases in such quantities as to endanger persons shall not be permitted.
- (d) A portable froth applicator unit shall consist of an inductor type of air-froth nozzle capable of being connected to the fire main by a fire hose, together with a portable tank containing at least 20 litres (4½ gallons) of froth-making liquid and one spare tank. The nozzle shall be capable of producing effective froth suitable for extinguishing an oil fire, at the rate of at least 1.5 cubic metres (53 cubic feet) per minute.
- (e) Fire extinguishers shall be periodically examined and subjected to such tests as the Administration may require.
- (f) One of the portable fire extinguishers intended for use in any space shall be stowed near the entrance to that space.

Regulation 8. Fixed Gas Fire-Extinguishing Systems

- (a) The use of a fire-extinguishing medium which, in the opinion of the Administration, either by itself or under expected conditions of use gives off toxic gases in such quantities as to endanger persons shall not be permitted.
- (b) Where provision is made for the injection of gas for fire-extinguishing purposes, the necessary pipes for conveying the gas shall be provided with control valves or cocks so marked as to indicate clearly the compartments to which the pipes are led. Suitable provision shall be made to prevent inadvertent admission of the gas to any compartment. Where cargo spaces fitted with such a system for fire protection are used as passenger spaces the gas connexion shall be blanked during such use.
- (c) The piping shall be arranged so as to provide effective distribution of fire-extinguishing gas.
- (d) (i) When carbon dioxide is used as the extinguishing medium in cargo spaces, the quantity of gas available shall be sufficient to give a minimum volume of free gas equal to 30 per cent of the gross volume of the largest cargo compartment in the ship which is capable of being sealed.
- (ii) When carbon dioxide is used as an extinguishing medium for machinery spaces of Category A the quantity of gas carried shall be sufficient to give a minimum quantity of free gas equal to the larger of the following quantities, either:
 - (1) 40 per cent of the gross volume of the largest space, the volume to include the casing up to the level at which the horizontal area of the casing is 40 per cent or less of the horizontal area of the space concerned taken midway between the tank top and the lowest part of the casing; or
 - (2) 35 per cent of the entire volume of the largest space including the casing;provided that the above-mentioned percentages may be reduced to 35 per cent and 30 per cent respectively for cargo ships of less than 2,000 tons gross tonnage; provided also that if two or more machinery spaces of Category A are not entirely separate they shall be considered as forming one compartment.

- (iii) Where the volume of free air contained in air receivers in any machinery space of Category A is such that, if released in such space in the event of fire, such release of air within that space would seriously affect the efficiency of the fixed fire-extinguishing installation, the Administration shall require the provision of an additional quantity of carbon dioxide.
 - (iv) When carbon dioxide is used as an extinguishing medium both for cargo spaces and for machinery spaces of Category A the quantity of gas need not be more than the maximum required either for the largest cargo compartment or machinery space.
 - (v) For the purpose of this paragraph the volume of carbon dioxide shall be calculated at 0.56 cubic metres to the kilogramme (9 cubic feet to the pound).
 - (vi) When carbon dioxide is used as the extinguishing medium for machinery spaces of Category A the fixed piping system shall be such that 85 per cent of the gas can be discharged into the space within 2 minutes.
 - (vii) Carbon dioxide bottle storage rooms shall be situated at a safe and readily accessible position and shall be effectively ventilated to the satisfaction of the Administration. Any entrance to such storage rooms shall preferably be from the open deck, and in any case shall be independent of the protected space. Access doors shall be gastight and bulkheads and decks which form the boundaries of such rooms shall be gastight and adequately insulated.
- (e) (i) Where gas other than carbon dioxide or steam as permitted by paragraph (f) of this Regulation is produced on the ship and is used as an extinguishing medium, it shall be a gaseous product of fuel combustion in which the oxygen content, the carbon monoxide content, the corrosive elements and any solid combustible elements have been reduced to a permissible minimum.
- (ii) Where such gas is used as the extinguishing medium in a fixed fire-extinguishing system for the protection of machinery spaces of Category A it shall afford protection equivalent to that provided by a fixed carbon dioxide system.
- (iii) Where such gas is used as the extinguishing medium in a fixed fire-extinguishing system for the protection of cargo spaces a sufficient quantity of such gas shall be available to supply hourly a volume of free gas at least equal to 25 per cent of the gross volume of the largest compartment protected in this way for a period of 72 hours.
- (f) In general, the Administration shall not permit the use of steam as a fire-extinguishing medium in fixed fire-extinguishing systems of new ships. Where the use of steam is permitted by the Administration it shall be used only in restricted areas as an addition to the required fire-extinguishing medium and with the proviso that the boiler or boilers available for supplying steam shall have an evaporation of at least 1 kilogramme of steam per hour for each 0.75 cubic metres (1 pound of steam per hour per 12 cubic feet) of the gross volume of the largest space so protected. In addition to complying with the foregoing requirements the systems in all respects shall be as determined by, and to the satisfaction of the Administration.
- (g) Means shall be provided for automatically giving audible warning of the release of fire-extinguishing gas into any space to which personnel normally have access. The alarm shall operate for a suitable period before the gas is released.

- (h) The means of control of any such fixed gas fire-extinguishing system shall be readily accessible and simple to operate and shall be grouped together in as few locations as possible at positions not likely to be cut off by a fire in the protected space.

Regulation 9. Fixed Froth Fire-Extinguishing Systems in Machinery Spaces

- (a) Any required fixed froth fire-extinguishing system in machinery spaces shall be capable of discharging through fixed discharge outlets in not more than five minutes, a quantity of froth sufficient to cover to a depth of 150 millimetres (6 inches) the largest single area over which oil fuel is liable to spread. The system shall be capable of generating froth suitable for extinguishing oil fires. Means shall be provided for effective distribution of the froth through a permanent system of piping and control valves or cocks to suitable discharge outlets, and for the froth to be effectively directed by fixed sprayers on other main fire hazards in the protected space. The expansion ratio of the froth shall not exceed 12 to 1.
- (b) The means of control of any such systems shall be readily accessible and simple to operate and shall be grouped together in as few locations as possible at positions not likely to be cut off by a fire in the protected space.

Regulation 10. Fixed High Expansion Froth Fire-Extinguishing Systems in Machinery Spaces

- (a) (i) Any required fixed high expansion froth system in machinery spaces shall be capable of rapidly discharging through fixed discharge outlets a quantity of froth sufficient to fill the greatest space to be protected at a rate of at least 1 metre (3.3 feet) in depth per minute. The quantity of froth-forming liquid available shall be sufficient to produce a volume of froth equal to five times the volume of the largest space to be protected. The expansion ratio of the froth shall not exceed 1,000 to 1.
- (ii) The Administration may permit alternative arrangements and discharge rates provided that it is satisfied that equivalent protection is achieved.
- (b) Supply ducts for delivering froth, air intakes to the froth generator and the number of froth-producing units shall in the opinion of the Administration be such as will provide effective froth production and distribution.
- (c) The arrangement of the froth generator delivery ducting shall be such that a fire in the protected space will not affect the froth-generating equipment.
- (d) The froth generator, its sources of power supply, froth-forming liquid and means of controlling the system shall be readily accessible and simple to operate and shall be grouped in as few locations as possible at positions not likely to be cut off by fire in the protected space.

Regulation 11. Fixed Pressure Water-Spraying Fire-Extinguishing Systems in Machinery Spaces

- (a) Any required fixed pressure water-spraying fire-extinguishing system in machinery spaces shall be provided with spraying nozzles of an approved type.
- (b) The number and arrangement of the nozzles shall be to the satisfaction of the Administration and be such as to ensure an effective average distribution of water of at least 5 litres per square metre (0.1 gallon per square foot) per minute in the spaces to be protected. Where increased application rates are considered necessary, these shall be to the satisfaction of the Administration. Nozzles shall be fitted above bilges, tank tops and other areas over which oil fuel is liable to spread and also above other specific fire hazards in the machinery spaces.

- (c) The system may be divided into sections, the distribution valves of which shall be operated from easily accessible positions outside the spaces to be protected and which will not be readily cut off by an outbreak of fire.
- (d) The system shall be kept charged at the necessary pressure and the pump supplying the water for the system shall be put automatically into action by a pressure drop in the system.
- (e) The pump shall be capable of simultaneously supplying at the necessary pressure all sections of the system in any one compartment to be protected. The pump and its controls shall be installed outside the space or spaces to be protected. It shall not be possible for a fire in the space or spaces protected by the water-spraying system to put the system out of action.
- (f) The pump may be driven by independent internal combustion type machinery but if it is dependent upon power being supplied from the emergency generator fitted in compliance with the provisions of Regulation 25 or Regulation 26 as appropriate of Chapter II-1 of the present Convention that generator shall be arranged to start automatically in case of main power failure so that power for the pump required by paragraph (e) of this Regulation is immediately available. When the pump is driven by independent internal combustion type machinery it shall be so situated that a fire in the protected space will not affect the air supply to the machinery.
- (g) Precautions shall be taken to prevent the nozzles from becoming clogged by impurities in the water or corrosion of piping, nozzles, valves and pump.

Regulation 12. Automatic Sprinkler and Fire Alarm and Fire Detection Systems

- (a) (i) Any required automatic sprinkler and fire alarm and fire detection system shall be capable of immediate operation at all times and no action by the crew shall be necessary to set it in operation. It shall be of the wet pipe type but small exposed sections may be of the dry pipe type where in the opinion of the Administration this is a necessary precaution. Any parts of the system which may be subjected to freezing temperatures in service shall be suitably protected against freezing. It shall be kept charged at the necessary pressure and shall have provision for a continuous supply of water as required in this Regulation.
- (ii) Each section of sprinklers shall include means for giving a visual and audible alarm signal automatically at one or more indicating units whenever any sprinkler comes into operation. Such units shall give an indication of any fire and its location in any space served by the system and shall be centralized on the navigating bridge or in the main fire control station, which shall be so manned or equipped as to ensure that any alarm from the system is immediately received by a responsible member of the crew. Such alarm systems shall be constructed so as to indicate if any fault occurs in the system.
- (b) (i) Sprinklers shall be grouped into separate sections, each of which shall contain not more than 200 sprinklers. Any section of sprinklers shall not serve more than two decks and shall not be situated in more than one main vertical zone, except that an Administration, if it is satisfied that the protection of the ship against fire will not thereby be reduced, may permit such a section of sprinklers to serve more than two decks or to be situated in more than one main vertical zone.
- (ii) Each section of sprinklers shall be capable of being isolated by one stop valve only. The stop valve in each section shall be readily accessible and its location shall be clearly and permanently indicated. Means shall be provided to prevent the operation of the stop valves by any unauthorized person.

- (iii) A gauge indicating the pressure in the system shall be provided at each section stop valve and at a central station.
 - (iv) The sprinklers shall be resistant to corrosion by marine atmospheres. In accommodation and service spaces the sprinklers shall come into operation within the temperature range of 68°C (155°F) and 79°C (175°F), except that in locations such as drying rooms, where high ambient temperatures might be expected, the operating temperature may be increased by not more than 30°C (54°F) above the maximum deck head temperature.
 - (v) A list or plan shall be displayed at each indicating unit showing the spaces covered and the location of the zone in respect of each section. Suitable instructions for testing and maintenance shall be available.
- (c) Sprinklers shall be placed in an overhead position and spaced in a suitable pattern to maintain an average application rate of not less than 5 litres per square metre (0.1 gallon per square foot) per minute over the nominal area covered by the sprinklers. Alternatively, the Administration may permit the use of sprinklers providing such other amount of water suitably distributed as has been shown to the satisfaction of the Administration to be not less effective.
- (d) (i) A pressure tank having a volume equal to at least twice that of the charge of water specified in this sub-paragraph shall be provided. The tank shall contain a standing charge of fresh water, equivalent to the amount of water which would be discharged in one minute by the pump referred to in sub-paragraph (e)(ii) of this Regulation, and the arrangements shall provide for maintaining such air pressure in the tank to ensure that where the standing charge of fresh water in the tank has been used the pressure will be not less than the working pressure of the sprinkler, plus the pressure due to a head of water measured from the bottom of the tank to the highest sprinkler in the system. Suitable means of replenishing the air under pressure and of replenishing the fresh water charge in the tank shall be provided. A glass gauge shall be provided to indicate the correct level of the water in the tank.
- (ii) Means shall be provided to prevent the passage of sea water into the tank.
- (e) (i) An independent power pump shall be provided solely for the purpose of continuing automatically the discharge of water from the sprinklers. The pump shall be brought into action automatically by the pressure drop in the system before the standing fresh water charge in the pressure tank is completely exhausted.
- (ii) The pump and the piping system shall be capable of maintaining the necessary pressure at the level of the highest sprinkler to ensure a continuous output of water sufficient for the simultaneous coverage of a minimum area of 280 square metres (3,000 square feet) at the application rate specified in paragraph (c) of this Regulation.
- (iii) The pump shall have fitted on the delivery side a test valve with a short open-ended discharge pipe. The effective area through the valve and pipe shall be adequate to permit the release of the required pump output while maintaining the pressure in the system specified in sub-paragraph (d)(i) of this Regulation.
- (iv) The sea inlet to the pump shall wherever possible be in the space containing the pump and shall be so arranged that when the ship is afloat it will not be necessary to shut off the supply of sea water to the pump for any purpose other than the inspection or repair of the pump.

- (f) The sprinkler pump and tank shall be situated in a position reasonably remote from any machinery space of Category A and shall not be situated in any space required to be protected by the sprinkler system.
- (g) There shall be not less than two sources of power supply for the sea water pump and automatic alarm and detection system. Where the sources of power for the pump are electrical, these shall be a main generator and an emergency source of power. One supply for the pump shall be taken from the main switchboard, and one from the emergency switchboard by separate feeders reserved solely for that purpose.

The feeders shall be arranged so as to avoid galleys, machinery spaces and other enclosed spaces of high fire risk except in so far as it is necessary to reach the appropriate switchboards, and shall be run to an automatic change-over switch situated near the sprinkler pump. This switch shall permit the supply of power from the main switchboard so long as a supply is available therefrom, and be so designed that upon failure of that supply it will automatically change over to the supply from the emergency switchboard. The switches on the main switchboard and the emergency switchboard shall be clearly labelled and normally kept closed. No other switch shall be permitted in the feeders concerned. One of the sources of power supply for the alarm and detection system shall be an emergency source. Where one of the sources of power for the pump is an internal combustion-type engine it shall, in addition to complying with the provisions of paragraph (f) of this Regulation, be so situated that a fire in any protected space will not affect the air supply to the machinery.

- (h) The sprinkler system shall have a connexion from the ship's fire main by way of a lockable screw-down non-return valve at the connexion which will prevent a backflow from the sprinkler system to the fire main.
- (i)
 - (i) A test valve shall be provided for testing the automatic alarm for each section of sprinklers by a discharge of water equivalent to the operation of one sprinkler. The test valve for each section shall be situated near the stop valve for that section.
 - (ii) Means shall be provided for testing the automatic operation of the pump, on reduction of pressure in the system.
 - (iii) Switches shall be provided at one of the indicating positions referred to in sub-paragraph (a)(ii) of this Regulation which will enable the alarm and the indicators for each section of sprinklers to be tested.
- (j) Spare sprinkler heads shall be provided for each section of sprinklers to the satisfaction of the Administration.

Regulation 13. Automatic Fire Alarm and Fire Detection Systems

Requirements for passenger ships carrying more than 36 passengers

- (a)
 - (i) Any required automatic fire alarm and fire detection system shall be capable of immediate operation at all times and no action of the crew shall be necessary to set it in operation.

- (ii) Each section of detectors shall include means for giving a visual and audible alarm signal automatically at one or more indicating units whenever any detector comes into operation. Such units shall give an indication of any fire and its location in any space served by the system and shall be centralized on the navigating bridge or in the main fire control station which shall be so manned or equipped as to ensure that any alarm from the system is immediately received by a responsible member of the crew. Such alarm system shall be constructed so as to indicate if any fault occurs in the system.
- (b) Detectors shall be grouped into separate sections each covering not more than 50 rooms served by such a system and containing not more than 100 detectors. A section of detectors shall not serve spaces on both the port and starboard sides of the ship nor on more than one deck and neither shall it be situated in more than one main vertical zone except that the Administration, if it is satisfied that the protection of the ship against fire will not thereby be reduced, may permit such a section of detectors to serve both the port and starboard sides of the ship and more than one deck.
- (c) The system shall be operated by an abnormal air temperature, by an abnormal concentration of smoke or by other factors indicative of incipient fire in any one of the spaces to be protected. Systems which are sensitive to air temperature shall not operate at less than 57°C (135deg.F) and shall operate at a temperature not greater than 74deg.C (165°F) when the temperature increase to those levels is not more than 1deg.C (1.8°F) per minute. At the discretion of the Administration the permissible temperature of operation may be increased to 30deg.C (54deg.F) above the maximum deckhead temperature in drying rooms and similar places of a normally high ambient temperature. Systems which are sensitive to smoke concentration shall operate on the reduction of the intensity of a transmitted light beam by an amount to be determined by the Administration. Other equally effective methods of operation may be accepted at the discretion of the Administration. The detection system shall not be used for any purpose other than fire detection.
- (d) The detectors may be arranged to operate the alarm by the opening or closing of contacts or by other appropriate methods. They shall be fitted in an overhead position and shall be suitably protected against impact and physical damage. They shall be suitable for use in a marine atmosphere. They shall be placed in an open position clear of beams and other objects likely to obstruct the flow of hot gases or smoke to the sensitive element. Detectors operated by the closing of contacts shall be of the sealed contact type and the circuit shall be continuously monitored to indicate fault conditions.
- (e) At least one detector shall be installed in each space where detection facilities are required and there shall be not less than one detector for each 37 square metres (400 square feet) of deck area. In large spaces the detectors shall be arranged in a regular pattern so that no detector is more than 9 metres (30 feet) from another detector or more than 4.5 metres (15 feet) from a bulkhead.
- (f) There shall be not less than two sources of power supply for the electrical equipment used in the operation of the fire alarm and fire detection system, one of which shall be an emergency source. The supply shall be provided by separate feeders reserved solely for that purpose. Such feeders shall run to a change-over switch situated in the control station for the fire detection system. The wiring system shall be so arranged to avoid galleys, machinery spaces and other enclosed spaces having a high fire risk except in so far as it is necessary to provide for fire detection in such spaces or to reach the appropriate switchboard.

- (g) (i) A list or plan shall be displayed adjacent to each indicating unit showing the spaces covered and the location of the zone in respect of each section. Suitable instructions for testing and maintenance shall be available.
- (ii) Provision shall be made for testing the correct operation of the detectors and the indicating units by supplying means for applying hot air or smoke at detector positions.
- (h) Spare detector heads shall be provided for each section of detectors to the satisfaction of the Administration.

Requirements for all other types of ships

- (i) All required fire detection systems shall be capable of automatically indicating the presence or indication of fire and also its location. Indicators shall be centralized either on the navigating bridge or in other control stations which are provided with a direct communication with the bridge. The Administration may permit the indicators to be distributed among several stations.
- (j) In passenger ships electrical equipment used in the operation of required fire detection systems shall have two separate sources of power, one of which shall be an emergency source.
- (k) The alarm system shall operate both audible and visible signals at the main stations referred to in paragraph (i) of this Regulation. Detection systems for cargo spaces need not have audible alarms.

Regulation 14. Fireman's Outfit

A fireman's outfit shall consist of:

- (a) Personal equipment comprising:
 - (i) Protective clothing of material to protect the skin from the heat radiating from the fire and from burns and scalding by steam. The outer surface shall be water-resistant.
 - (ii) Boots and gloves of rubber or other electrically non-conducting material.
 - (iii) A rigid helmet providing effective protection against impact.
 - (iv) An electric safety lamp (hand lantern) of an approved type with a minimum burning period of three hours.
 - (v) An axe to the satisfaction of the Administration.
- (b) A breathing apparatus of an approved type which may be either:
 - (i) A smoke helmet or smoke mask which shall be provided with a suitable air pump and a length of air hose sufficient to reach from the open deck, well clear of hatch or doorway, to any part of the holds or machinery spaces. If, in order to comply with this sub-paragraph, an air hose exceeding 36 metres (120 feet) in length would be necessary, a self-contained breathing apparatus shall be substituted or provided in addition as determined by the Administration, or
 - (ii) a self-contained breathing apparatus which shall be capable of functioning for a period of time to be determined by the Administration.

For each breathing apparatus a fireproof lifeline of sufficient length and strength shall be provided capable of being attached by means of a snaphook to the harness of the apparatus or to a separate belt in order to prevent the breathing apparatus becoming detached when the lifeline is operated.

Regulation 15. Ready Availability of Fire-Extinguishing Appliances

In all new and existing ships, fire-extinguishing appliances shall be kept in good order and available for immediate use at all times during the voyage.

Regulation 16. Acceptance of Substitutes

Where in this Chapter any special type of appliance, apparatus, extinguishing medium or arrangement is specified in any new and existing ships, any other type of appliance *etc.*, may be allowed, provided the Administration is satisfied that it is not less effective.

PART B FIRE SAFETY MEASURES FOR PASSENGER SHIPS CARRYING MORE THAN 36 PASSENGERS

Regulation 17. Structure

The hull, superstructure, structural bulkheads, decks and deckhouses shall be constructed of steel or other equivalent material. For the purpose of applying the definition of steel or other equivalent material as given in Regulation 3(g) of this Chapter the "applicable fire exposure" shall be according to the integrity and insulation standards given in the tables of Regulation 20 of this Chapter. An example where divisions such as decks or sides and ends of deckhouses are permitted to have "B-0" fire integrity, the "applicable fire exposure" shall be one half-hour.

Provided that in cases where any part of the structure is of aluminium alloy, the following requirements shall apply:

- (a) The insulation of aluminium alloy components of 'A' or 'B' Class divisions, except structure which in the opinion of the Administration is non-load-bearing, shall be such that the temperature of the structural core does not rise more than 200°C (360°F) above the ambient temperature at any time during the applicable fire exposure to the standard fire test.
- (b) Special attention shall be given to the insulation of aluminium alloy components of columns, stanchions and other structural members required to support lifeboat and liferaft stowage, launching and embarkation areas, and 'A' and 'B' Class divisions to ensure:
 - (i) that for such members supporting lifeboat and liferaft areas and 'A' Class divisions the temperature rise limitation specified in paragraph (a) of this Regulation shall apply at the end of one hour; and
 - (ii) that for such members required to support 'B' Class divisions, the temperature rise limitation specified in paragraph (a) of this Regulation shall apply at the end of one half-hour.
- (c) Crowns and casings of machinery spaces of Category A shall be of steel construction adequately insulated and openings therein, if any, shall be suitably arranged and protected to prevent the spread of fire.

Regulation 18. Main Vertical Zones and Horizontal Zones

- (a) The hull, superstructure and deckhouses shall be subdivided into main vertical zones by 'A' Class divisions. Steps and recesses shall be kept to a minimum, but where they are necessary, they shall also be 'A' Class divisions. These divisions shall have insulation values in accordance with the applicable tables in Regulation 20 of this Chapter.
- (b) As far as practicable, the bulkheads forming the boundaries of the main vertical zones above the bulkhead deck shall be in line with watertight sub-division bulkheads situated immediately below the bulkhead deck.
- (c) Such bulkheads shall extend from deck to deck and to the shell or other boundaries.
- (d) Where a main vertical zone is subdivided by horizontal 'A' Class divisions into horizontal zones for the purpose of providing an appropriate barrier between sprinklered and non-sprinklered zones of the ship the divisions shall extend between adjacent main vertical zone bulkheads and to the shell or exterior boundaries of the ship and shall be insulated in accordance with the fire insulation and integrity values given in Table 3 of Regulation 20 of this Chapter.
- (e) On ships designed for special purposes, such as automobile or railroad car ferries, where the provision of main vertical zone bulkheads would defeat the purpose for which the ship is intended, equivalent means for controlling and limiting a fire shall be substituted and specially approved by the Administration.

Provided that in a ship with special category spaces, any such space shall comply with the applicable provisions of Regulation 30 of this Chapter, and in so far as such compliance would be inconsistent with compliance with other requirements of this Part of this Chapter, the requirements of Regulation 30 shall prevail.

Regulation 19. Bulkheads Within A Main Vertical Zone

- (a) All bulkheads which are not required to be 'A' Class divisions shall be at least 'B' Class or 'C' Class divisions as prescribed in the tables in Regulation 20 of this Chapter. All such divisions may be faced with combustible materials in accordance with the provisions of Regulation 27 of this Chapter.
- (b) All corridor bulkheads where not required to be 'A' Class shall be 'B' Class divisions which shall extend from deck to deck except:
 - (i) when continuous 'B' Class ceilings and/or linings are fitted on both sides of the bulkhead, the portion of the bulkhead behind the continuous ceiling or lining shall be of material which in thickness and composition is acceptable in the construction of 'B' Class divisions but which shall be required to meet 'B' Class integrity standards only in so far as is reasonable and practicable in the opinion of the Administration;
 - (ii) in the case of a ship protected by an automatic sprinkler system complying with the provisions of Regulation 12 of this Chapter, the corridor bulkheads of 'B' Class materials may terminate at a ceiling in the corridor provided such a ceiling is of material which in thickness and composition is acceptable in the construction of 'B' Class divisions. Notwithstanding the requirements of Regulation 20 of this Chapter, such bulkheads and ceilings shall be required to meet 'B' Class integrity standards only in so far as is reasonable and practicable in the opinion of the Administration. All doors and frames in such bulkheads

shall be of incombustible materials and shall be constructed and erected so as to provide substantial fire resistance to the satisfaction of the Administration.

- (c) All bulkheads required to be 'B' Class divisions, except corridor bulkheads, shall extend from deck to deck and to the shell or other boundaries unless continuous 'B' Class ceilings and/or linings are fitted on both sides of the bulkhead in which case the bulkhead may terminate at the continuous ceiling or lining.

Regulation 20. Fire Integrity of Bulkheads and Decks

- (a) In addition to complying with the specific provisions for fire integrity of bulkheads and decks mentioned elsewhere in the Regulations of this Part, the minimum fire integrity of all bulkheads and decks shall be as prescribed in Tables 1 to 4 in this Regulation. Where, due to any particular structural arrangements in the ship, difficulty is experienced in determining from the tables the minimum fire integrity value of any divisions, such values shall be determined to the satisfaction of the Administration.

- (b) The following requirements shall govern application of the tables:

- (i) Table 1 shall apply to bulkheads bounding main vertical zones or horizontal zones.

Table 2 shall apply to bulkheads not bounding either main vertical zones or horizontal zones.

Table 3 shall apply to decks forming steps in main vertical zones or bounding horizontal zones.

Table 4 shall apply to decks not forming steps in main vertical zones nor bounding horizontal zones.

- (ii) For the purpose of determining the appropriate fire integrity standards to be applied to boundaries between adjacent spaces, such spaces are classified according to their fire risk as shown in Categories (1) to (14) below. Where the contents and use of a space are such that there is a doubt as to its classification for the purpose of this Regulation, it shall be treated as a space within the relevant category having the most stringent boundary requirements. The title of each category is intended to be typical rather than restrictive. The number in parentheses preceding each category refers to the applicable column or row number in the tables.

(1) *Control stations*

- Spaces containing emergency sources of power and lighting.
- Wheelhouse and chartroom.
- Spaces containing the ship's radio equipment.
- Fire control and recording stations.
- Control room for propelling machinery when located outside the propelling machinery space.
- Spaces containing centralized fire alarm equipment.
- Spaces containing centralized emergency public address system stations and equipment.

(2) *Stairways*

- Interior stairways, lifts and escalators (other than those wholly contained within the machinery spaces) for passengers and crew and enclosures thereto; In this connexion, a stairway which is enclosed at only one level shall be regarded as part of the space from which it is not separated by a fire door.

(3) *Corridors*

- Passenger and crew corridors.

(4) *Lifeboat and life raft handling and embarkation stations*

- Open deck spaces and enclosed promenades forming lifeboat and liferaft embarkation and lowering stations.

(5) *Open deck spaces*

- Open deck spaces and enclosed promenades clear of lifeboat and liferaft embarkation and lowering stations.
- Air space (the space outside superstructures and deckhouses).

(6) *Accommodation spaces of minor fire risk*

- Cabins containing furniture and furnishings of restricted fire risk.
- Public spaces containing furniture and furnishings of restricted fire risk.
- Public spaces containing furniture and furnishings of restricted fire risk and having a deck area of less than 50 square metres (540 square feet).
- Offices and dispensaries containing furniture and furnishings of restricted fire risk.

(7) *Accommodation spaces of moderate fire risk*

- Same as (6) above but containing furniture and furnishings of other than restricted fire risk.
- Public spaces containing furniture and furnishings of restricted fire risk and having a deck area of 50 square metres (540 square feet) and greater.
- Isolated lockers and small store-rooms in accommodation spaces.
- Sales shops.
- Motion picture projection and film stowage rooms.
- Diet kitchens (containing no open flame).
- Cleaning gear lockers (in which inflammable liquids are not stowed).
- Laboratories (in which inflammable liquids are not stowed).
- Pharmacies.
- Small drying rooms (having a deck area of 4 square metres (43 square feet) or less).
- Specie rooms.

(8) *Accommodation spaces of greater fire risk*

- Public spaces containing furniture and furnishings of other than restricted fire risk and having a deck area of 50 square metres (540 square feet) and greater.
- Barber shops and beauty parlours.

(9) *Sanitary and similar spaces*

- Communal sanitary facilities, showers, baths, water closets, *etc.*
- Small laundry rooms.
- Indoor swimming pool area.
- Operating rooms.
- Isolated serving pantries in accommodation spaces.
- Private sanitary facilities shall be considered a portion of the space in which they are located.

(10) *Tanks, voids and auxiliary machinery spaces having little or no fire risk*

- Water tanks forming part of the ship's structure.
- Voids and cofferdams.
- Auxiliary machinery spaces which do not contain machinery having a pressure lubrication system and where storage of combustibles is prohibited, such as ventilation and air-conditioning rooms; windlass room; steering gear room; stabilizer equipment room; electrical propulsion motor room; rooms containing section switchboards and purely electrical equipment other than oil-filled electrical transformers (above 10kVA); shaft alleys and pipe tunnels; spaces for pumps and refrigeration machinery (not handling or using inflammable liquids).
- Closed trunks serving the spaces listed above.
- Other closed trunks such as pipe and cable trunks.

(11) *Auxiliary machinery spaces, cargo spaces, special category spaces, cargo and other oil tanks and other similar spaces of moderate fire risk*

- Cargo oil tanks.
- Cargo holds, trunkways and hatchways.
- Refrigerated chambers.
- Oil fuel tanks (where installed in a separate space with no machinery).
- Shaft alleys and pipe tunnels allowing storage of combustibles.
- Auxiliary machinery spaces as in Category (10) which contain machinery having a pressure lubrication system or where storage of combustibles is permitted.
- Oil fuel filling stations.
- Spaces containing oil-filled electrical transformers (above 10kVA).
- Spaces containing turbine and reciprocating steam engine driven auxiliary generators and small internal combustion engines of power output up to 112 kW driving emergency generators, sprinkler, drencher or fire pumps, bilge pumps, *etc.*
- Special category spaces (Tables 1 and 3 only apply).
- Closed trunks serving the spaces listed above.

(12) *Machinery spaces and main galleys*

- Main propelling machinery rooms (other than electric propulsion motor rooms) and boiler rooms.

- Auxiliary machinery spaces other than those in Categories (10) and (11) which contain internal combustion machinery or other oil-burning, heating or pumping units.
- Main galleys and annexes.
- Trunks and casings to the spaces listed above.

(13) *Store-rooms, workshops, pantries, etc.*

- Main pantries not annexed to galleys.
- Main laundry.
- Large drying rooms (having a deck area of more than 4 square metres (43 square feet)).
- Miscellaneous stores.
- Mail and baggage rooms.
- Garbage rooms.
- Workshops (not part of machinery spaces, galleys, *etc.*).

(14) *Other spaces in which inflammable liquids are stowed*

- Lamp rooms.
- Paint rooms.
- Store-rooms containing inflammable liquids (including dyes, medicines, *etc.*).
- Laboratories (in which inflammable liquids are stowed).

- (iii) Where a single value is shown for the fire integrity of a boundary between two spaces, that value shall apply in all cases.
- (iv) In determining the applicable fire integrity standard of a boundary between two spaces within a main vertical zone or horizontal zone which is not protected by an automatic sprinkler system complying with the provision of Regulation 12 of this Chapter or between such zones neither of which is so protected, the higher of the two values given in the tables shall apply.
- (v) In determining the applicable fire integrity standard of a boundary between two spaces within a main vertical zone or horizontal zone which is protected by an automatic sprinkler system complying with the provisions of Regulation 12 of this Chapter or between such zones both of which are so protected, the lesser of the two values given in the tables shall apply. In instances where a sprinklered zone and a non-sprinklered zone meet within accommodation and service spaces, the higher of the two values given in the tables shall apply to the division between the zones.
- (vi) Where adjacent spaces are in the same numerical category and the superscript "1" appears in the tables, a bulkhead or deck between such spaces need not be fitted if deemed unnecessary by the Administration. For example, in Category (12) a bulkhead need not be required between a galley and its annexed pantries provided the pantry bulkheads and decks maintain the integrity of the galley boundaries. A bulkhead is, however, required between a galley and a machinery space even though both spaces are in Category (12).

- (vii) Where the superscript "2" appears in the tables, the lesser insulation value may be permitted only if at least one of the adjoining spaces is protected by an automatic sprinkler system complying with the provisions of Regulation 12 of this Chapter.
 - (viii) Notwithstanding the provisions of Regulation 19 of this Chapter, there are no special requirements for material or integrity of boundaries where only a dash appears in the tables.
 - (ix) The Administration shall determine in respect of Category (5) spaces whether the insulation values in Table 1 or 2 shall apply to ends of deckhouses and superstructures, and whether the insulation values in Table 3 or 4 shall apply to weather decks. In no case shall the requirements of Category (5) of Tables 1 to 4 necessitate enclosure of spaces which in the opinion of the Administration need not be enclosed.
- (c) Continuous 'B' Class ceilings or linings, in association with the relevant decks or bulkheads, may be accepted as contributing wholly or in part, to the required insulation and integrity of a division.
 - (d) In approving structural fire protection details, the Administration shall have regard to the risk of heat transmission at intersections and terminal points of required thermal barriers.

TABLE 1 BULKHEADS BOUNDING MAIN VERTICAL ZONES OR HORIZONTAL ZONES

Spaces		(1)	(2)	(3)	(4)	(5)	(6)	(7)	(8)	(9)	(10)	(11)	(12)	(13)	(14)
Control stations	(1)	A-60	A-30	A-30	A-0	A-0	A-60	A-60	A-60	A-0	A-0	A-60	A-60	A-60	A-60
Stairways	(2)		A-0	A-0	A-0	A-0	A-15 A-0	A-30 A-0	A-60 A-15	A-0	A-0	A-30	A-60	A-15 A-0	A-60
Corridors	(3)			A-0	A-0	A-0	A-0	A-30 A-0	A-30 A-0	A-0	A-0	A-30	A-60	A-15 A-0	A-60
Lifeboat and liferaft handling and embarking stations	(4)				-	-	A-0	A-0	A-0	A-0	A-0	A-0	A-60	A-0	A-60
Open deck spaces	(5)					-	A-0	A-0	A-0	A-0	A-0	A-0	A-0	A-0	A-0
Accommodation spaces of minor fire risk	(6)						A-15 A-0	A-30 A-0	A-30 A-0	A-0	A-0	A-15 A-0	A-30	A-15 A-0	A-30
Accommodation spaces of moderate fire risk	(7)							A-30 A-0	A-60 A-15	A-0	A-0	A-30 A-0	A-60	A-30 A-0	A-60
Accommodation spaces of greater fire risk	(8)								A-60 A-15	A-0	A-0	A-60 A-15	A-60	A-30 A-0	A-60
Sanitary and similar spaces	(9)									A-0	A-0	A-0	A-0	A-0	A-0
Tanks, voids and auxiliary machinery spaces having little or no fire risk	(10)										A-0	A-0	A-0	A-0	A-0
Auxiliary machinery spaces, cargo spaces, special category spaces, cargo and other oil tanks and other similar spaces of moderate fire risk	(11)											A-0	A-60	A-0	A-60
Machinery spaces and main galleys	(12)												A-60	A-30 ² A-15	A-60
Store rooms, workshops, pantries, etc.	(13)													A-0	A-30
Other spaces in which inflammable liquids are stowed	(14)														A-60

TABLE 2 BULKHEADS NOT BOUNDING EITHER MAIN VERTICAL ZONES OR HORIZONTAL ZONES

Spaces		(1)	(2)	(3)	(4)	(5)	(6)	(7)	(8)	(9)	(10)	(11)	(12)	(13)	(14)
Control stations	(1)	B-0 ¹	A-0	A-0	A-0	A-0 B-0	A-60	A-60	A-60	A-0	A-0	A-60	A-60	A-60	A-60
Stairways	(2)		A-0 ¹	A-0	A-0	A-0	A-0	A-15 A-0	A-30 A-0	A-0	A-0	A-15	A-30	A-15 A-0	A-30
Corridors	(3)			C	A-0	A-0 B-0	B-0	B-15 B-0	B-15 B-0	B-0	A-0	A-15	A-30	A-0	A-30 A-0
Lifeboat and liferaft handling and embarking stations	(4)				-	-	A-0	A-0	A-0	A-0	A-0	A-0	A-15	A-0	A-15 A-0
Open deck spaces	(5)					-	A-0 B-0	A-0 B-0	A-0 B-0	A-0 B-0	A-0	A-0	A-0	A-0 B-0	A-0 B-0
Accommodation spaces of minor fire risk	(6)						B-0 C	B-15 C	B-15 C	B-0 C	A-0	A-15 A-0	A-30	A-0	A-30 A-0
Accommodation spaces of moderate fire risk	(7)							B-15 C	B-15 C	B-0 C	A-0	A-15 A-0	A-60	A-15 A-0	A-60 A-15
Accommodation spaces of greater fire risk	(8)							B-15 C	B-0 C	A-0	A-30 A-0	A-60	A-60	A-15 A-0	A-60 A-15
Sanitary and similar spaces	(9)									C	A-0	A-0	A-0	A-0	A-0
Tanks, voids and auxiliary machinery spaces having little or no fire risk	(10)										A-0 ¹	A-0	A-0	A-0	A-0
Auxiliary machinery spaces, cargo spaces, special category spaces, cargo and other oil tanks and other similar spaces of moderate fire risk	(11)											A-0 ¹	A-0	A-0	A-30 ² A-15
Machinery spaces and main galleys	(12)												A-0	A-0	A-60
Store rooms, workshops, pantries, etc.	(13)													A-0 ¹	A-0
Other spaces in which flammable liquids are stowed	(14)														A-30 ² A-15

TABLE 3 DECKS FORMING STEPS IN MAIN VERTICAL ZONES OR BOUNDING HORIZONTAL ZONES



Space below  Space above 		(1)	(2)	(3)	(4)	(5)	(6)	(7)	(8)	(9)	(10)	(11)	(12)	(13)	(14)
Control stations	(1)	A-60	A-60	A-30	A-0	A-0	A-15	A-30	A-60	A-0	A-0	A-30	A-60	A-15	A-60
Stairways	(2)	A-15	A-0	A-0	A-0	A-0	A-0	A-15 A-0	A-15 A-0	A-0	A-0	A-0	A-60	A-0	A-60
Corridors	(3)	A-30	A-0	A-0	A-0	A-0	A-0	A-15 A-0	A-15 A-0	A-0	A-0	A-0	A-60	A-0	A-60
Lifeboat and liferaft handling and embarkation stations	(4)	A-0	A-0	A-0	A-0	A-0	A-0	A-0	A-0	A-0	A-0	A-0	A-0	A-0	A-0
Open deck spaces	(5)	A-0	A-0	A-0	A-0	A-0	A-0	A-0	A-0	A-0	A-0	A-0	A-0	A-0	A-0
Accommodation spaces of minor fire risk	(6)	A-60	A-30 A-0	A-15 A-0	A-0	A-0	A-0	A-15 A-0	A-30 A-0	A-0	A-0	A-15 A-0	A-15	A-0	A-15
Accommodation spaces of moderate fire risk	(7)	A-60	A-60 A-15	A-30 A-0	A-15 A-0	A-0	A-15 A-0	A-30 A-0	A-60 A-15	A-0	A-0	A-30 A-0	A-30	A-0	A-30
Accommodation spaces of greater fire risk	(8)	A-60	A-60 A-15	A-60 A-15	A-60 A-15	A-0	A-30 A-0	A-60 A-15	A-60 A-15	A-0	A-0	A-30 A-0	A-60	A-15 A-0	A-60
Sanitary and similar spaces	(9)	A-0	A-0	A-0	A-0	A-0	A-0	A-0	A-0	A-0	A-0	A-0	A-0	A-0	A-0
Tanks, voids and auxiliary machinery spaces having little or no fire risk	(10)	A-0	A-0	A-0	A-0	A-0	A-0	A-0	A-0	A-0	A-0	A-0	A-0	A-0	A-0
Auxiliary machinery spaces, cargo spaces, special category spaces, cargo and other oil tanks and other similar spaces of moderate fire risk	(11)	A-60	A-60	A-60	A-60	A-0	A-30 A-0	A-60 A-15	A-60 A-15	A-0	A-0	A-0	A-30	A-30 ² A-0	A-30
Machinery spaces and main galleys	(12)	A-60	A-60	A-60	A-60	A-0	A-60	A-60	A-60	A-0	A-0	A-60	A-60	A-60	A-60
Store rooms, workshops, pantries, etc.	(13)	A-60	A-60 A-15	A-30 A-0	A-15	A-0	A-15 A-0	A-30 A-0	A-60 A-15	A-0	A-0	A-0	A-30	A-0	A-30
Other spaces in which flammable liquids are stowed	(14)	A-60	A-60	A-60	A-60	A-0	A-60	A-60	A-60	A-0	A-0	A-60	A-60	A-60	A-60

TABLE 4 - DECKS NOT FORMING STEPS IN MAIN VERTICAL ZONES NOR BOUNDING HORIZONTAL ZONES

<i>Space below</i> ↓	<i>Space above</i> →		(1)	(2)	(3)	(4)	(5)	(6)	(7)	(8)	(9)	(10)	(11)	(12)	(13)	(14)
Control stations	(1)	A-30 A-0	A-30 A-0	A-15 A-0	A-0	A-0 B-0	A-0	A-15 A-0	A-30 A-0	A-0	A-0	A-0	A-60	A-0	A-60 A-15	
Stairways	(2)	A-0	A-0	A-0	A-0	A-0 B-0	A-0	A-0	A-0	A-0	A-0	A-0	A-30	A-0	A-30 A-0	
Corridors	(3)	A-15 A-0	A-0	A-0 ¹ B-0 ¹	A-0	A-0 B-0	A-0 B-0	A-15 B-0	A-15 B-0	A-0 B-0	A-0	A-0	A-30	A-0	A-30 A-0	
Lifeboat and liferaft handling and embarkation stations	(4)	A-0	A-0	A-0	A-0	-	A-0 B-0	A-0 B-0	A-0 B-0	A-0 B-0	A-0	A-0	A-0	A-0	A-0	
Open deck spaces	(5)	A-0	A-0	A-0 B-0	A-0	-	A-0 B-0	A-0 B-0	A-0 B-0	A-0 B-0	A-0	A-0	A-0	A-0 B-0	A-0	
Accommodation spaces of minor fire risk	(6)	A-60	A-15 A-0	A-0	A-0	A-0 B-0	A-0 B-0	A-0 B-0	A-0 B-0	A-0 B-0	A-0	A-0	A-15 A-0	A-0	A-15 A-0	
Accommodation spaces of moderate fire risk	(7)	A-60	A-30 A-0	A-15 A-0	A-15 A-0	A-0 B-0	A-0 B-0	A-15 B-0	A-30 B-0	A-0 B-0	A-0	A-15 A-0	A-30 A-0	A-0	A-30 A-0	
Accommodation spaces of greater fire risk	(8)	A-60	A-60 A-15	A-60 A-0	A-30 A-0	A-0 B-0	A-15 B-0	A-30 B-0	A-60 B-0	A-0 B-0	A-0	A-30 A-0	A-30 A-0	A-0	A-30 A-0	
Sanitary and similar spaces	(9)	A-0	A-0	A-0 B-0	A-0	A-0 B-0	A-0 B-0	A-0 B-0	A-0 B-0	A-0 B-0	A-0	A-0	A-0	A-0	A-0	
Tanks, voids and auxiliary machinery spaces having little or no fire risk	(10)	A-0	A-0	A-0	A-0	A-0	A-0	A-0	A-0	A-0	A-0	A-0	A-0	A-0	A-0	
Auxiliary machinery spaces, cargo spaces, special category spaces, cargo and other oil tanks and other similar spaces of moderate fire risk	(11)	A-60	A-60 A-15	A-60 A-15	A-30 A-0	A-0	A-0	A-15 A-0	A-30 A-0	A-0	A-0	A-0 ¹	A-0	A-0	A-30 ² A-15	
Machinery spaces and main galleys	(12)	A-60	A-60	A-60	A-60	A-0	A-60	A-60	A-60	A-0	A-0	A-30	A-30 ¹	A-0	A-60	
Store rooms, workshops, pantries, etc.	(13)	A-60	A-30 A-0	A-15 A-0	A-15 A-0	A-0 B-0	A-15 A-0	A-30 A-0	A-30 A-0	A-0 B-0	A-0	A-0	A-0	A-0	A-15 ² A-0	
Other spaces in which flammable liquids are stowed	(14)	A-60	A-60 A-30	A-60 A-30	A-60	A-0	A-30 A-0	A-60 A-15	A-60 A-15	A-0	A-0	A-30 ² A-0	A-30 ² A-0	A-0	A-30 ² A-0	

Regulation 21. Means of Escape

- (a) In and from all passenger and crew spaces and spaces in which the crew is normally employed, other than machinery spaces, stairways and ladders shall be arranged to provide ready means of escape to the lifeboat and liferaft embarkation deck. In particular, the following provisions shall be complied with:
- (i) Below the bulkhead deck, two means of escape, at least one of which shall be independent of watertight doors, shall be provided from each watertight compartment or similarly restricted space or group of spaces. Exceptionally, the Administration may dispense with one of the means of escape, due regard being paid to the nature and location of spaces and to the number of persons who normally might be quartered or employed there.
 - (ii) Above the bulkhead deck, there shall be at least two means of escape from each main vertical zone or similarly restricted space or group of spaces at least one of which shall give access to a stairway forming a vertical escape.
 - (iii) At least one of the means of escape required by sub-paragraphs (a)(i) and (ii) of this Regulation shall be by means of a readily accessible enclosed stairway, which shall provide continuous fire shelter from the level of its origin to the appropriate lifeboat and liferaft embarkation decks or the highest level served by the stairway, whichever level is the highest. However, where an Administration has granted dispensation under the provisions of sub-paragraph (a)(i) of this Regulation the sole means of escape shall provide safe escape to the satisfaction of the Administration. The width, number and continuity of the stairways shall be to the satisfaction of the Administration.
 - (iv) Protection of access from the stairway enclosures to the lifeboat and liferaft embarkation areas shall be to the satisfaction of the Administration.
 - (v) Lifts shall not be considered as forming one of the required means of escape.
 - (vi) Stairways serving only a space and a balcony in that space shall not be considered as forming one of the required means of escape.
 - (vii) If a radiotelegraph station has no direct access to the weather deck, two means of escape shall be provided from such station.
 - (viii) Dead-end corridors exceeding 13 metres (43 feet) shall not be permitted.
- (b) (i) In special category spaces the number and disposition of the means of escape both below and above the bulkhead deck shall be to the satisfaction of the Administration, and in general the safety of access to the embarkation deck shall be at least equivalent to that provided for under sub-paragraphs (a)(i), (ii), (iii), (iv) and (v) of this Regulation.
- (ii) One of the escape routes from the machinery spaces where the crew is normally employed shall avoid direct access to any special category space.

- (c) Two means of escape shall be provided from each machinery space. In particular, the following provisions shall be complied with:
- (i) Where the space is below the bulkhead deck the two means of escape shall consist of either:
 - (1) two sets of steel ladders as widely separated as possible, leading to doors in the upper part of the space similarly separated and from which access is provided to the appropriate lifeboat and liferaft embarkation decks. One of these ladders shall provide continuous fire shelter from the lower part of the space to a safe position outside the space; or
 - (2) one steel ladder leading to a door in the upper part of the space from which access is provided to the embarkation deck and a steel door capable of being operated from each side and which provides a safe escape route to the embarkation deck.
 - (ii) Where the space is above the bulkhead deck, two means of escape shall be as widely separated as possible and the doors leading from such means of escape shall be in position from which access is provided to the appropriate lifeboat and liferaft embarkation decks. Where such escapes require the use of ladders these shall be of steel.

Provided that in a ship of less than 1,000 tons gross tonnage, the Administration may dispense with one of the means of escape due regard being paid to the width and disposition of the upper part of the space; and in a ship of 1,000 tons gross tonnage and above, the Administration may dispense with one means of escape from any such space so long as either a door or a steel ladder provides a safe escape route to the embarkation deck due regard being paid to the nature and location of the space and whether persons are normally employed in that space.

Regulation 22. Protection of Stairways and Lifts in Accommodation and Service Spaces

- (a) All stairways shall be of steel frame construction except where the Administration sanctions the use of other equivalent material, and shall be within enclosures formed of 'A' Class divisions, with positive means of closure at all openings, except that:
 - (i) a stairway connecting only two decks need not be enclosed, provided the integrity of the deck is maintained by proper bulkheads or doors at one between deck space. When a stairway is closed at one between deck space, the stairway enclosure shall be protected in accordance with the tables for decks in Regulation 20 of this Chapter;
 - (ii) stairways may be fitted in the open in a public space, provided they lie wholly within such public space.
- (b) Stairway enclosures shall have direct communication with the corridors and be of sufficient area to prevent congestion, having in view the number of persons likely to use them in an emergency. In so far as practicable, stairway enclosures shall not give direct access to cabins, service lockers, or other enclosed spaces containing combustibles in which a fire is likely to originate.
- (c) Lift trunks shall be so fitted as to prevent the passage of smoke and flame from one between deck to another and shall be provided with means of closing so as to permit the control of draught and smoke.

Regulation 23 Openings in 'A' Class Divisions

- (a) Where 'A' Class divisions are pierced for the passage of electric cables, pipes, trunks, ducts, etc., for girders, beams or other structures, arrangements shall be made to ensure that the fire resistance is not impaired, subject to the provisions of paragraph (g) of this Regulation.
- (b) Where of necessity, a ventilation duct passes through a main vertical zone bulkhead, a fail-safe automatic closing fire damper shall be fitted adjacent to the bulkhead. The damper shall also be capable of being manually closed from each side of the bulkhead. The operating position shall be readily accessible and be marked in red light-reflecting colour. The duct between the bulkhead and the damper shall be of steel or other equivalent material and, if necessary, to an insulating standard such as to comply with paragraph (a) of this Regulation. The damper shall be fitted on at least one side of the bulkhead with a visible indicator showing if the damper is in the open position.
- (c) Except for hatches between cargo, special category, store, and baggage spaces, and between such spaces and the weather decks, all openings shall be provided with permanently attached means of closing which shall be at least as effective for resisting fires as the divisions in which they are fitted.
- (d) The construction of all doors and door frames in 'A' Class divisions, with the means of securing them when closed, shall provide resistance to fire as well as to the passage of smoke and flame, as far as practicable, equivalent to that of the bulkheads in which the doors are situated. Such doors and door frames shall be constructed of steel or other equivalent material. Watertight doors need not be insulated.
- (e) It shall be possible for each door to be opened and closed from each side of the bulkhead by one person only.
- (f) Fire doors in main vertical zone bulkheads and stairway enclosures, other than power-operated watertight doors and those which are normally locked, shall be of the self-closing type capable of closing against an inclination of 31/2 degrees opposing closure. The speed of door closure shall, if necessary, be controlled so as to prevent undue danger to personnel. All such doors, except those that are normally closed, shall be capable of release from a control station, either simultaneously or in groups, and also individually from a position at the door. The release mechanism shall be so designed that the door will automatically close in the event of disruption of the control system; however, approved power-operated watertight doors will be considered acceptable for this purpose. Hold-back hooks, not subject to control station release, will not be permitted. When double swing doors are permitted, they shall have a latch arrangement which is automatically engaged by the operation of the door release system.
- (g) Where a space is protected by an automatic sprinkler system complying with the provisions of Regulation 12 of this Chapter or fitted with a continuous 'B' Class ceiling, openings in decks not forming steps in main vertical zones nor bounding horizontal zones shall be closed reasonably tight and such decks shall meet the 'A' Class integrity requirements in so far as is reasonable and practicable in the opinion of the Administration.
- (h) The requirements for 'A' Class integrity of the outer boundaries of a ship shall not apply to glass partitions, windows and sidescuttles. Similarly, the requirements for 'A' Class integrity shall not apply to exterior doors in superstructures and deckhouses.

Regulation 24. Openings in 'B' Class Divisions

- (a) Where 'B' Class divisions are penetrated for the passage of electrical cables, pipes, trunks, ducts, etc., or for the fitting of ventilation terminals, lighting fixtures and similar devices, arrangements shall be made to ensure that the fire resistance is not impaired.
- (b) Doors and door frames in 'B' Class divisions and means of securing them shall provide a method of closure which shall have resistance to fire as far as practicable equivalent to the divisions except that ventilation openings may be permitted in the lower portion of such doors. Where such opening is in or under a door the total net area of any such opening or openings shall not exceed 0.05 square metres (78 square inches). When such opening is cut in a door it shall be fitted with a grill made of non-combustible material. Doors shall be non-combustible.
- (c) The requirements for 'B' Class integrity of the outer boundaries of a ship shall not apply to glass partitions, windows and side scuttles. Similarly, the requirements for 'B' Class integrity shall not apply to exterior doors in superstructures and deckhouses.
- (d) Where an automatic sprinkler system complying with the provisions of Regulation 12 of this Chapter is fitted:
 - (i) openings in decks not forming steps in main vertical zones nor bounding horizontal zones shall be closed reasonably tight and such decks shall meet the 'B' Class integrity requirements in so far as is reasonable and practicable in the opinion of the Administration; and
 - (ii) openings in corridor bulkheads of 'B' Class materials shall be protected in accordance with the provisions of Regulation 19 of this Chapter.

Regulation 25. Ventilation Systems

- (a) In general, the ventilation fans shall be so disposed that the ducts reaching the various spaces remain within the main vertical zone.
- (b) Where ventilation systems penetrate decks, precautions shall be taken, in addition to those relating to the fire integrity of the deck required by Regulation 23 of this Chapter, to reduce the likelihood of smoke and hot gases passing from one between deck space to another through the system. In addition to insulation requirements contained in this Regulation, vertical ducts shall, if necessary, be insulated as required by the appropriate tables in Regulation 20 of this Chapter.
- (c) The main inlets and outlets of all ventilation systems shall be capable of being closed from outside the space being ventilated.
- (d) Except in cargo spaces, ventilation ducts shall be constructed of the following materials:
 - (i) Ducts not less than 0.075 square metres (116 square inches) in sectional area and all vertical ducts serving more than a single between deck space shall be constructed of steel or other equivalent material.
 - (ii) Ducts less than 0.075 square metres (116 square inches) in sectional area shall be constructed of non-combustible materials. Where such ducts penetrate 'A' or 'B' Class divisions due regard shall be given to ensuring the fire integrity of the division.

- (iii) Short lengths of duct, not in general exceeding 0.02 square metres (31 square inches) in sectional area nor 2 metres (79 inches) in length, need not be incombustible provided that all of the following conditions are met:
 - (1) the duct is constructed of a material of restricted fire risk to the satisfaction of the Administration;
 - (2) the duct is used only at the terminal end of the ventilation system; and
 - (3) the duct is not located closer than 0.6 metres (24 inches) measured along its length to a penetration of an 'A' or 'B' Class division, including continuous 'B' Class ceilings.
- (e) Where a stairway enclosure is ventilated, the duct or ducts (if any) shall be taken from the fan room independently of other ducts in the ventilation system and shall not serve any other space.
- (f) All power ventilation, except machinery and cargo spaces ventilation and any alternative system which may be required under paragraph (h) of this Regulation, shall be fitted with controls so grouped that all fans may be stopped from either of two separate positions which shall be situated as far apart as practicable. Controls provided for the power ventilation serving machinery spaces shall also be grouped so as to be operable from two positions, one of which shall be outside such spaces. Fans serving power ventilation systems to cargo spaces shall be capable of being stopped from a safe position outside such spaces.
- (g) Where they pass through accommodation spaces or spaces containing combustible materials, the exhaust ducts from galley ranges shall be constructed of 'A' Class divisions. Each exhaust duct shall be fitted with:
 - (i) a grease trap readily removable for cleaning;
 - (ii) a fire damper located in the lower end of the duct;
 - (iii) arrangements, operable from within the galley, for shutting off the exhaust fan; and
 - (iv) fixed means for extinguishing a fire within the duct.
- (h) Such measures as are practicable shall be taken in respect of control stations outside machinery spaces in order to ensure that ventilation, visibility and freedom from smoke are maintained, so that in the event of fire the machinery and equipment contained therein may be supervised and continue to function effectively. Alternative and separate means of air supply shall be provided; air inlets of the two sources of supply shall be so disposed that the risk of both inlets drawing in smoke simultaneously is minimized. At the discretion of the Administration, such requirements need not apply to control stations situated on, and opening on to, an open deck, or where local closing arrangements would be equally effective.
- (i) Ducts provided for ventilation of machinery spaces of Category A shall not in general pass through accommodation, service spaces or control stations, except that the Administration may permit relaxation from this requirement, provided that:
 - (i) the ducts are constructed of steel, and are insulated to "A-60" standard; or

- (ii) the ducts are constructed of steel and are fitted with an automatic fire damper close to the boundary penetrated and are insulated to "A-60" standard from the machinery space to a point at least 5 metres (16 feet) beyond the fire damper.
- (j) Ducts provided for ventilation of accommodation, service spaces, or control stations shall not in general pass through machinery spaces of Category A, except that the Administration may permit relaxation from this requirement provided that the ducts are constructed of steel and automatic fire dampers are fitted close the boundaries penetrated.

Regulation 26. Windows and Side scuttles

- (a) All windows and side scuttles in bulkheads within accommodation and service spaces and control stations other than those to which the provisions of paragraph (h) of Regulation 23 and paragraph (c) of Regulation 24 of this Chapter apply, shall be constructed so as to preserve the integrity requirements of the type of bulkheads in which they are fitted.
- (b) Notwithstanding the requirements of the tables in Regulation 20 of this Chapter:
 - (i) All windows and side scuttles in bulkheads separating accommodation and service spaces and control stations from weather shall be constructed with frames of steel or other suitable material. The glass shall be retained by a metal glazing bead or angle.
 - (ii) Special attention shall be given to the fire integrity of windows facing open or enclosed lifeboat and life raft embarkation areas and to windows situated below such areas in such a position that their failure during a fire would impede the launching of, or embarkation into, lifeboats or liferafts.

Regulation 27. Restriction of Combustible Materials

- (a) Except in cargo spaces, mail rooms, baggage rooms, or refrigerated compartments of service spaces, all linings, grounds, ceilings and insulations shall be of non-combustible materials. Partial bulkheads or decks used to subdivide a space for utility or artistic treatment shall also be of non-combustible material.
- (b) Vapour barriers and adhesives used in conjunction with insulation, as well as insulation of pipe fittings, for cold service systems need not be non-combustible, but they shall be kept to the minimum quantity practicable and their exposed surfaces shall have qualities of resistance to the propagation of flame to the satisfaction of the Administration.
- (c) Bulkheads, linings and ceilings, in all accommodation and service spaces may have combustible veneer, provided that such veneer shall not exceed 2 millimetres (1/12 inch) within any such spaces except corridors, stairway enclosures and control stations where it shall not exceed 1.5 millimetres (1/17 inch).
- (d) The total volume of combustible facings, mouldings, decorations and veneers in any accommodation and service space shall not exceed a volume equivalent to 2.5 millimetres (1/10 inch) veneer on the combined area of the walls and ceilings. In the case of ships fitted with an automatic sprinkler system complying with the provisions of Regulation 12 of this Chapter, the above volume may include some combustible material used for erection of 'C' Class divisions.

- (e) All exposed surfaces in corridors or stairway enclosures and surfaces in concealed or inaccessible spaces in accommodation and service spaces and control stations shall have low flame-spread characteristics.¹³
- (f) Furniture in the passages and stairway enclosures shall be kept to a minimum.
- (g) Paints, varnishes and other finishes used on exposed interior surfaces shall not be of a nature to offer an undue fire hazard in the judgment of the Administration and shall not be capable of producing excessive quantities of smoke or other toxic properties.
- (h) Primary deck coverings, if applied, within accommodation and service spaces and control stations, shall be of approved material which will not readily ignite, or give rise to toxic or explosive hazards at elevated temperatures.¹⁴
- (i) Waste-paper receptacles shall be constructed of non-combustible materials and with solid sides and bottoms.

Regulation 28. Miscellaneous Items

Requirements applicable to all portions of the ship

- (a) Pipes penetrating 'A' or 'B' Class divisions shall be of a material approved by the Administration having regard to the temperature such divisions are required to withstand. Pipes conveying oil or combustible liquids shall be of a material approved by the Administration having regard to the fire risk. Materials readily rendered ineffective by heat shall not be used for overboard scuppers, sanitary discharges, and other outlets which are close to the water-line and where the failure of the material in the event of fire would give rise to danger of flooding.

Requirements applicable to accommodation and service spaces, control stations, corridors and stairways

- (b) (i) Air spaces enclosed behind ceilings, panelling or linings shall be suitably divided by close-fitting draught stops not more than 14 metres (46 feet) apart.
 - (ii) In the vertical direction, such spaces, including those behind linings of stairways, trunks, etc., shall be closed at each deck.
- (c) The construction of ceiling and bulkheading shall be such that it will be possible, without impairing the efficiency of the fire protection, for the fire patrols to detect any smoke originating in concealed and inaccessible places, except where in the opinion of the Administration there is no risk of fire originating in such places.

Regulation 29. Automatic Sprinkler and Fire Alarm and Fire Detection Systems or Automatic Fire Alarm and Fire Detection Systems

In any ship to which this Part applies there shall be installed throughout each separate zone, whether vertical or horizontal, in all accommodation and service spaces and, where it is considered necessary by the Administration, in control stations, except spaces which afford no substantial fire risk (such as void spaces, sanitary spaces, etc.) either:

¹³ Reference is made to Guidelines on the Evaluation of Fire Hazard Properties of Materials, adopted by the Organization by Resolution A.166(ES.IV).

¹⁴ Reference is made to Improved Provisional Guidelines on Test Procedures for Primary Deck Coverings, adopted by the Organization by Resolution A.214(VII).

- (i) an automatic sprinkler and fire alarm and fire detection system of an approved type, complying with the provisions of Regulation 12 of this Chapter and installed and so arranged as to protect such spaces; or
- (ii) an automatic fire alarm and fire detection system of an approved type, complying with the provisions of Regulation 13 of this Chapter, and installed and so arranged as to detect the presence of fire in such spaces.

Regulation 30. Protection of Special Category Spaces

Provisions applicable to special category spaces whether above or below the bulkhead deck

(a) *General*

- (i) The basic principle underlying the provisions in this Regulation is that as normal main vertical zoning may not be practicable in special category spaces, equivalent protection must be obtained in such spaces on the basis of a horizontal zone concept and the provisions of an efficient fixed fire-extinguishing system. Under this concept a horizontal zone for the purpose of this Regulation may include special category spaces on more than one deck provided that the overall height of the zone does not exceed 10 metres (33 feet).
- (ii) All requirements laid down in Regulations 23 and 25 of this Chapter for maintaining the integrity of vertical zones shall be applied equally to decks and bulkheads forming the boundaries separating horizontal zones from each other and from the remainder of the ship.

(b) *Structural protection*

- (i) Boundary bulkheads of special category spaces shall be insulated as required for Category (11) spaces in Table 1 of Regulation 20 of this Chapter and the horizontal boundaries as required for Category (11) spaces in Table 3 of that Regulation.
- (ii) Indicators shall be provided on the navigating bridge which shall indicate when any fire door leading to or from the special category spaces is closed.

(c) *Fixed fire-extinguishing system*¹⁵

Each special category space shall be fitted with an approved fixed pressure water-spraying system for manual operation which shall protect all parts of any deck and vehicle platform, if any, in such space, provided that the Administration may permit the use of any other fixed fire-extinguishing system that has been shown by full-scale test in conditions simulating a flowing petrol fire in a special category space to be not less effective in controlling fires likely to occur in such a space.

(d) *Patrols and detection*

- (i) An efficient patrol system shall be maintained in special category spaces. In any such space in which the patrol is not maintained by a continuous fire watch at all times during the voyage there shall be provided in that space an automatic fire detection system of an approved type.

¹⁵ Reference is made to Recommendation on Fixed Fire Extinguishing Systems for Special Category Spaces, adopted by the Organization by Resolution A.123(V).

- (ii) Manual fire alarms shall be provided as necessary throughout the special category spaces and one shall be placed close to each exit from such spaces.
- (e) *Fire-extinguishing equipment.* There shall be provided in each special category space:
- (i) a number of hydrants with hoses and dual-purpose nozzles of an approved type so arranged that at least two jets of water each from a single length of hose not emanating from the same hydrant may reach any part of such space;
 - (ii) at least three water fog applicators;
 - (iii) one portable applicator unit complying with the provisions of Regulation 7(d) of this Chapter, provided that at least two such units are available in the ship for use in such spaces; and
 - (iv) such number of portable fire extinguishers of an approved type as the Administration may deem sufficient.
- (f) *Ventilation system*
- (i) There shall be provided an effective power ventilation system for the special category spaces sufficient to give at least 10 air changes per hour. The system for such spaces shall be entirely separated from other ventilation systems and shall be operating at all times when vehicles are in such spaces. The Administration may require an increased number of air changes when vehicles are being loaded and unloaded.
 - (ii) The ventilation shall be such as to prevent air stratification and the formation of air pockets.
 - (iii) Means shall be provided to indicate on the navigating bridge any loss or reduction of the required ventilating capacity.

Additional provisions applicable only to special category spaces above the bulkhead deck

- (g) *Scuppers.* In view of the serious loss of stability which could arise due to large quantities of water accumulating on the deck or decks consequent on the operation of the fixed pressure water-spraying system, scuppers shall be fitted so as to ensure that such water is rapidly discharged directly overboard.
- (h) *Precautions against ignition of inflammable vapours*
- (i) Equipment which may constitute a source of ignition of inflammable vapours and in particular electrical equipment and wiring, shall be installed at least 450 millimetres (18 inches) above the deck, provided that if the Administration is satisfied that the installation of such electrical equipment and wiring below this level is necessary for the safe operation of the ship, such electrical equipment and wiring shall be of a type approved for use in an explosive petrol and air mixture. Electrical equipment installed at more than 450 millimetres (18 inches) above the deck shall be of a type so enclosed and protected as to prevent the escape of sparks. The reference to a level of 450 millimetres (18 inches) above the deck shall be construed to mean each deck on which vehicles are carried and on which explosive vapours might be expected to accumulate.
 - (ii) Electrical equipment and wiring, if installed in an exhaust ventilation duct, shall be of a type approved for use in explosive petrol and air mixtures and the outlet from any exhaust duct shall be sited in a safe position, having regard to other possible sources of ignition.

Additional provisions applicable only to special category spaces below the bulkhead deck

- (i) *Bilge pumping and drainage.* In view of the serious loss of stability which could arise due to large quantities of water accumulating on the deck or tank top consequent on the operation of the fixed pressure water-spraying system, the Administration may require pumping and drainage facilities to be provided additional to the requirements of Regulation 18 of Chapter II-1 of the present Convention.
- (j) *Precautions against ignition of inflammable vapours*
 - (i) Electrical equipment and wiring, if fitted, shall be of a type suitable for use in explosive petrol and air mixtures. Other equipment which may constitute a source of ignition of inflammable vapours shall not be permitted.
 - (ii) Electrical equipment and wiring, if installed in an exhaust ventilation duct, shall be of a type approved for use in explosive petrol and air mixtures and the outlet from any exhaust duct shall be sited in a safe position, having regard to other possible sources of ignition.

Regulation 31. Protection of Cargo Spaces Other Than Special Category Spaces Intended For The Carriage of Motor Vehicles with Fuel in Their Tanks for Their Own Propulsion

In any cargo space (other than special category spaces) containing motor vehicles with fuel in their tanks for their own propulsion, the following provisions shall be complied with:

(a) *Fire detection*

There shall be provided an approved fire detection and fire alarm system.

(b) *Fire-extinguishing arrangements*

- (i) There shall be fitted a fixed gas fire-extinguishing system which shall comply with the provisions of Regulation 8 of this Chapter, except that if a carbon dioxide system is fitted, the quantity of gas available shall be at least sufficient to give a minimum volume of free gas equal to 45 per cent of the gross volume of the largest of such cargo spaces which is capable of being sealed, and the arrangements shall be such as to ensure that the gas is introduced rapidly and effectively into the space. Any other fixed gas fire-extinguishing system or fixed high expansion froth fire-extinguishing system may be fitted provided it gives equivalent protection.
- (ii) There shall be provided for use in any such space such number of portable fire extinguishers of an approved type as the Administration may deem sufficient.

(c) *Ventilation system*

- (i) In any such cargo space there shall be provided an effective power ventilation system sufficient to give at least 10 air changes per hour. The system for such cargo spaces shall be entirely separated from other ventilation systems and shall be operating at all times when vehicles are in such spaces.
- (ii) The ventilation shall be such as to prevent air stratification and the formation of air pockets.

(iii) Means shall be provided to indicate on the navigating bridge any loss or reduction of the required ventilating capacity.

(d) *Precautions against ignition of inflammable vapours*

(i) Electrical equipment and wiring, if fitted, shall be of a type suitable for use in explosive petrol and air mixtures. Other equipment which may constitute a source of ignition of inflammable vapours shall not be permitted.

(ii) Electrical equipment and wiring, if installed in an exhaust ventilation duct, shall be of a type approved for use in explosive petrol and air mixtures and the outlet from any exhaust duct shall be sited in a safe position, having regard to other possible sources of ignition.

Regulation 32. Maintenance of Fire Patrols, etc., and Provision for Fire-Extinguishing Equipment

(a) *Fire patrols and detection, alarms and public address systems*

(i) An efficient patrol system shall be maintained so that an outbreak of fire may be promptly detected. Each member of the fire patrol shall be trained to be familiar with the arrangements of the ship as well as the location and operation of any equipment he may be called upon to use.

(ii) Manual alarms shall be fitted throughout the accommodation and service spaces to enable the fire patrol to give an alarm immediately to the navigating bridge or main fire control station.

(iii) An approved fire alarm or fire detecting system shall be provided which will automatically indicate at one or more suitable points or stations the presence or indication of fire and its location in any cargo space which, in the opinion of the Administration, is not accessible to the patrol system, except where it is shown to the satisfaction of the Administration that the ship is engaged on voyages of such short duration that it would be unreasonable to apply this requirement.

(iv) The ship shall at all times when at sea, or in port (except when out of service), be so manned or equipped as to ensure that any initial fire alarm is immediately received by a responsible member of the crew.

(v) A special alarm, operated from the navigating bridge or fire control station, shall be fitted to summon the crew. This alarm may be part of the ship's general alarm system but it shall be capable of being sounded independently of the alarm to the passenger spaces.

(vi) A public address system or other effective means of communication shall be available throughout the accommodation and service spaces and control stations.

(b) *Fire pumps and fire main system*

The ship shall be provided with fire pumps, fire main system, hydrants and hoses complying with the provisions of Regulation 5 of this Chapter and shall comply with the following requirements:

(i) In a ship of 4,000 tons gross tonnage and upwards, there shall be provided at least three independently-driven fire pumps and, in a ship of less than 4,000 tons gross tonnage, at least two such fire pumps.

- (ii) In a ship of 1,000 tons gross tonnage and upwards, the arrangement of sea connexions, fire pumps and sources of power for operating them shall be such as to ensure that a fire in any one compartment will not put all the fire pumps out of action.
- (iii) In a ship of 1,000 tons gross tonnage and upwards, the arrangement of fire pumps, fire mains and hydrants shall be such that at least one effective jet of water as stipulated in paragraph (c) of Regulation 5 of this Chapter is immediately available from any one hydrant in an interior location. Arrangements shall also be made to ensure the continuation of the output of water by the automatic starting of a required fire pump.
- (iv) In a ship of less than 1,000 tons gross tonnage the arrangements shall be to the satisfaction of the Administration.

(c) *Fire hydrants, hoses and nozzles*

- (i) The ship shall be provided with fire hoses the number and diameter of which shall be to the satisfaction of the Administration. There shall be at least one fire hose for each of the hydrants required by paragraph (d) of Regulation 5 of this Chapter and these hoses shall be used only for the purposes of extinguishing fires or testing the fire-extinguishing apparatus at fire drills and surveys.
- (ii) In accommodation and service spaces and in machinery spaces, the number and position of hydrants shall be such that the requirements of paragraph (d) of Regulation 5 of this Chapter may be complied with when all watertight doors and all doors in main vertical zone bulkheads are closed.
- (iii) The arrangements shall be such that at least two jets of water can reach any part of any cargo space when empty.
- (iv) All required hydrants in machinery spaces shall be fitted with hoses having in addition to the nozzles required in paragraph (g) of Regulation 5 of this Chapter nozzles suitable for spraying water on oil, or alternatively dual-purpose nozzles. Additionally, each machinery space of Category A shall be provided with at least two suitable water fog applicators.¹⁶
- (v) Water spray nozzles or dual-purpose nozzles shall be provided for at least one quarter of the number of hoses required in parts of the ship other than machinery spaces.
- (vi) For each pair of breathing apparatus there shall be provided one water fog applicator which shall be stored adjacent to such apparatus.
- (vii) Where, in any machinery space of Category A, access is provided at a low level from an adjacent shaft tunnel, two hydrants fitted with hoses with dual-purpose nozzles shall be provided external to, but near the entrance to that machinery space. Where such access is not provided from a tunnel but is provided from other space or spaces there shall be provided in one of those spaces two hydrants fitted with hoses with dual-purpose nozzles near the entrance to the machinery space of Category A. Such provision need not be made when the tunnel or adjacent spaces are not part of an escape route.

¹⁶ A water fog applicator might consist of a metal "L"-shaped pipe, the long limb being about 2 metres (6 feet) in length capable of being fitted to a fire hose and the short limb being about 250 millimetres (10 inches) in length fitted with a fixed water fog nozzle or capable of being fitted with a water spray nozzle.

(d) *International shore connexion*

- (i) A ship of 1,000 tons gross tonnage and upwards shall be provided with at least one international shore connexion, complying with the provisions of paragraph (h) of Regulation 5 of this Chapter.
- (ii) Facilities shall be available enabling such a connexion to be used on either side of the ship.

(e) *Portable fire extinguishers in accommodation and service spaces and control stations*

The ship shall be provided in accommodation and service spaces and control stations with such approved portable fire extinguishers as the Administration may deem to be appropriate and sufficient.

(f) *Fixed fire-extinguishing arrangements in cargo spaces*

- (i) The cargo spaces of ships of 1,000 tons gross tonnage and upwards shall be protected by a fixed gas fire-extinguishing system complying with the provisions of Regulation 8 of this Chapter, or by a fixed high expansion froth fire-extinguishing system which gives equivalent protection.
- (ii) Where it is shown to the satisfaction of the Administration that ship is engaged on voyages of such short duration that it would be unreasonable to apply the requirements of subparagraph (i) of this paragraph and also in ships of less than 1,000 tons gross tonnage, the arrangements in cargo spaces shall be to the satisfaction of the Administration.

(g) *Fire-extinguishing appliances in boiler rooms, etc.*

Spaces containing oil-fired boilers or oil fuel units shall be provided with the following arrangements:

- (i) There shall be any one of the following fixed fire-extinguishing systems:
 - (1) A pressure water-spraying system complying with the provisions of Regulation 11 of this Chapter.
 - (2) A gas system complying with the provisions of Regulation 8 of this Chapter.
 - (3) A froth system complying with the provisions of Regulation 9 of this Chapter.
 - (4) A high expansion froth system complying with the provisions of Regulation 10 of this Chapter.

In each case if the engine and boiler rooms are not entirely separate, or if fuel oil can drain from the boiler room into the engine room, the combined engine and boiler rooms shall be considered as one compartment.

- (ii) There shall be in each boiler room at least one set of portable air-froth equipment complying with the provisions of paragraph (d) of Regulation 7 of this Chapter.

- (iii) There shall be at least two approved portable extinguishers discharging froth or equivalent in each firing space in each boiler room and each space in which a part of the oil fuel installation is situated. There shall be not less than one approved froth-type extinguisher of at least 136 litres (30 gallons) capacity or equivalent in each boiler room. These extinguishers shall be provided with hoses on reels suitable for reaching any part of the boiler room.
- (iv) In each firing space there shall be a receptacle containing sand, sawdust impregnated with soda or other approved dry material, in such quantity as may be required by the Administration. Alternatively an approved portable extinguisher may be substituted therefor.

(h) Fire-extinguishing appliances in spaces containing internal combustion type machinery

Spaces containing internal combustion machinery used either for main propulsion, or for other purposes when such machinery has in the aggregate a total power output of not less than 373 kW, shall be provided with the following arrangements:

- (i) There shall be one of the fire-extinguishing systems required by sub-paragraph (g)(i) of this Regulation.
- (ii) There shall be at least one set of portable air-froth equipment complying with the provisions of paragraph (d) of Regulation 7 of this Chapter.
- (iii) There shall be in each such space approved froth-type fire extinguishers each of at least 45 litres (10 gallons) capacity or equivalent sufficient in number to enable froth or its equivalent to be directed on to any part of the fuel and lubricating oil pressure systems, gearing and other fire hazards. In addition, there shall be provided a sufficient number of portable froth extinguishers or equivalent which shall be so located that an extinguisher is not more than 10 metres (33 feet) walking distance from any point in the space; provided that there shall be at least two such extinguishers in each such space.

(i) Fire-extinguishing arrangements in spaces containing steam turbines or enclosed steam engines

In spaces containing steam turbines or enclosed steam engines used either for main propulsion or for other purposes when such machinery has in the aggregate a total power output of not less than 373 kW:

- (i) There shall be provided froth fire extinguishers each of at least 45 litres (10 gallons) capacity or equivalent sufficient in number to enable froth or its equivalent to be directed on to any part of the pressure lubrication system, on to any part of the casings enclosing pressure lubricated parts of the turbines, engines or associated gearing, and any other fire hazards. Provided that such extinguishers shall not be required if protection at least equivalent to this sub-paragraph is provided in such spaces by a fixed fire-extinguishing system fitted in compliance with sub-paragraph (g)(i) of this Regulation.
- (ii) There shall be provided a sufficient number of portable froth extinguishers or equivalent which shall be so located than an extinguisher is not more than 10 metres (33 feet) walking distance from any point in the space; provided that there shall be at least two such extinguishers in each such space, and such extinguishers shall not be required in addition to any provided in compliance with sub-paragraph (h)(iii) of this Regulation.

(j) *Fire-extinguishing appliances in other machinery spaces*

Where, in the opinion of the Administration, a fire hazard exists in any machinery space for which no specific provisions for fire-extinguishing appliances are prescribed in paragraphs (g), (h) and (i) of this Regulation there shall be provided in, or adjacent to, that space such number of approved portable fire extinguishers or other means of fire extinction as the Administration may deem sufficient.

(k) *Fixed fire-extinguishing appliances not required by this Part*

Where a fixed fire-extinguishing system not required by this Part of this Chapter is installed, such a system shall be to the satisfaction of the Administration.

(l) *Special requirements for machinery spaces*

- (i) For any machinery space of Category A to which access is provided at a low level from an adjacent shaft tunnel there shall be provided in addition to any watertight door and on the side remote from that machinery space a light steel fire-screen door which shall be operable from each side.
- (ii) An automatic fire detection and alarm system shall be fitted when the administration considers such special precautions warranted in any machinery space in which the installation of automatic and remote control systems and equipment have been approved in lieu of continuous manning of the space.

(m) *Fireman's outfits and personal equipment*

- (i) The minimum number of fireman's outfits complying with the requirements of Regulation 14 of this Chapter, and of additional sets of personal equipment, each such set comprising the items stipulated in sub-paragraphs(a)(i), (ii) and (iii) of that Regulation, to be carried shall be as follows:
 - (1) two fireman's outfits; and in addition
 - (2) for every 80 metres (262 feet) or part thereof, of the aggregate of the lengths of all passenger spaces and service spaces on the deck which carries such spaces or, if there is more than one such deck, on the deck which has the largest aggregate of such lengths, two fireman's outfits and two sets of personal equipment, each such set comprising the items stipulated in Regulation 14(a)(i), (ii) and (iii) of this Chapter.
- (ii) For each fireman's outfit which includes a self-contained breathing apparatus as provided in paragraph (b) of Regulation 14 of this Chapter, spare charges shall be carried on a scale approved by the Administration.
- (iii) Fireman's outfits and sets of personal equipment shall be stored in widely separated positions ready for use. At least two fireman's outfits and one set of personal equipment shall be available at any one position.

Regulation 33. Arrangements for Oil Fuel, Lubricating Oil and Other Inflammable Oils**(a) Oil fuel arrangements**

In a ship in which oil fuel is used, the arrangements for the storage, distribution and utilization of the oil fuel shall be such as to ensure the safety of the ship and persons on board and shall at least comply with the following provisions:

- (i) No oil fuel which has a flashpoint of less than 60°C (140°F) (closed cup test) as determined by an approved flashpoint apparatus shall be used as fuel, except in emergency generators, in which case the flashpoint shall be not less than 43°C (110°F).

Provided that the Administration may permit the general use of fuel oil having a flashpoint of not less than 43°C (110°F) subject to such additional precautions as it may consider necessary and on condition that the temperature of the space in which such fuel is stored or used shall not be allowed to rise within 10°C (18°F) below the flashpoint of the fuel.

- (ii) As far as practicable, no part of the oil fuel system containing heated oil under pressure exceeding 1.8 kilogrammes per square centimetre (25 pounds per square inch) gauge shall be so concealed that defects and leakage cannot readily be observed. In way of such parts of the oil fuel system the machinery space shall be adequately illuminated.

- (iii) The ventilation of machinery spaces shall be sufficient under all normal conditions to prevent accumulation of oil vapour.

- (iv) (1) As far as practicable, oil fuel tanks shall be part of the ship's structure and shall be located outside machinery spaces of Category A. When oil fuel tanks, except double bottom tanks, are necessarily located adjacent to machinery spaces of Category A, they shall preferably have a common boundary with the double bottom tanks, and the area of the tank boundary common with the machinery space shall be kept to a minimum. In general, the use of free-standing oil fuel tanks shall be avoided but when such tanks are employed they shall not be situated in machinery spaces of Category A.

- (2) No oil tank shall be situated where spillage or leakage therefrom can constitute a hazard by falling on heated surfaces. Precautions shall be taken to prevent any oil that may escape under pressure from any pump, filter or heater from coming into contact with heated surfaces.

- (v) Every oil fuel pipe which if damaged would allow oil to escape from a storage, settling or daily service tank situated above the double bottom shall be fitted with a cock or valve on the tank capable of being closed from a safe position outside the space concerned in the event of a fire arising in the space in which such tanks are situated. In the special case of deep tanks situated in any shaft or pipe tunnel or similar space, valves on the tanks shall be fitted but control in event of fire may be effected by means of an additional valve on the pipe or pipes outside the tunnel or similar space.

- (vi) Safe and efficient means of ascertaining the amount of oil fuel contained in any oil tank shall be provided. Sounding pipes with suitable means of closure may be permitted if their upper ends terminate in safe positions. Other means of ascertaining the amount of oil fuel contained in any oil fuel tank may be permitted if they do not require penetration below the top of the tank, and providing their failure or overfilling of the tanks will not permit release of fuel thereby.

- (vii) Provision shall be made to prevent over-pressure in any oil tank or in any part of the oil fuel system, including the filling pipes. Any relief valves and air or overflow pipes shall discharge to a position which, in the opinion of the Administration, is safe.
- (viii) Oil fuel pipes shall be of steel or other approved material, provided that restricted use of flexible pipes shall be permissible in positions where the Administration is satisfied that they are necessary. Such flexible pipes and end attachments shall be of approved fire-resisting materials of adequate strength and shall be constructed to the satisfaction of the Administration.

(b) *Lubricating oil arrangements*

The arrangements for the storage, distribution and utilization of oil used in pressure lubrication systems shall be such as to ensure the safety of the ships and persons on board, and such arrangements in machinery spaces of Category A and, whenever practicable, in other machinery spaces shall at least comply with the provisions of sub-paragraphs (ii), (iv)(2), (v), (vi) and (vii) of paragraph (a) of this Regulation.

(c) *Arrangements for other inflammable oils*

The arrangements for the storage, distribution and utilization of other inflammable oils employed under pressure in power transmission systems, control and activating systems and heating systems shall be such as to ensure the safety of the ship and persons on board. In locations where means of ignition are present such arrangements shall at least comply with the provisions of sub-paragraphs (a)(iv)(2) and (a)(vi), and with the provisions of sub-paragraph (a)(viii) in respect of strength and construction, of this Regulation.

Regulation 34. Special Arrangements in Machinery Spaces

- (a) The provisions of this Regulation shall apply to machinery spaces of Category A and, where the Administration considers it desirable, to other machinery spaces.
- (b)
 - (i) The number of skylights, doors, ventilators, openings in funnels to permit exhaust ventilation and other openings to machinery spaces shall be reduced to a minimum consistent with the needs of ventilation and the proper and safe working of the ship.
 - (ii) The flaps of such skylights where fitted shall be of steel. Suitable arrangements shall be made to permit the release of smoke in the event of fire, from the space to be protected.
 - (iii) Such doors other than power-operated watertight doors shall be arranged so that positive closure is assured in case of fire in the space, by power-operated closing arrangements or by the provision of self-closing doors capable of closing against an inclination of 31/2 degrees opposing closure and having a fail-safe hook-back facility, provided with a remotely operated release device.
- (c) Windows shall not be fitted in machinery space casings.
- (d) Means of control shall be provided for:
 - (i) opening and closure of skylights, closure of openings in funnels which normally allow exhaust ventilation, and closure of ventilator dampers;

- (ii) permitting the release of smoke;
 - (iii) closure of power-operated doors or release mechanism on doors other than power-operated watertight doors;
 - (iv) stopping ventilating fans; and
 - (v) stopping forced and induced draught fans, oil fuel transfer pumps, oil fuel unit pumps and other similar fuel pumps.
- (e) The controls required for ventilating fans shall comply with the provisions of paragraph (f) of Regulation 25 of this Chapter. The controls for any required fixed fire-extinguishing system and those required by sub-paragraphs (d)(i), (ii), (iii) and (v) of this Regulation and of sub-paragraph (a)(v) of Regulation 33 of this Chapter shall be situated at one control position, or grouped in as few positions as possible to the satisfaction of the Administration. Such position or positions shall be located where they will not be cut off in the event of fire in the space they serve, and shall have a safe access from the open deck.

PART C
FIRE SAFETY MEASURES FOR PASSENGER SHIPS
CARRYING NOT MORE THAN 36 PASSENGERS

Regulation 35. Structure

- (a) The hull, superstructure, structural bulkheads, decks and deckhouses shall be constructed of steel or other equivalent material.
- (b) Where fire protection in accordance with paragraph (b) of Regulation 40 of this Chapter is employed, the superstructure may be constructed of, for example, aluminium alloy, provided that:
 - (i) for the temperature rise of the metallic cores of 'A' Class divisions when exposed to the standard fire test, due regard is given to the mechanical properties of the material;
 - (ii) the Administration is satisfied that the amount of combustible materials used in the relevant part of the ship is suitably reduced; the ceilings (i.e. linings of deck heads) are non-combustible;
 - (iii) adequate provision is made to ensure that in the event of fire, arrangements for stowage, launching and embarkation into survival craft remain as effective as if the superstructure were constructed of steel;
 - (iv) crowns and casings of boiler and machinery spaces are of steel construction adequately insulated, and the openings therein, if any, are suitably arranged and protected to prevent spread of fire.

Regulation 36. Main Vertical Zones

- (a) The hull, superstructure and deckhouses shall be subdivided into main vertical zones. Steps and recesses shall be kept to a minimum, but where they are necessary, they shall be of 'A' Class divisions.

- (b) As far as practicable, the bulkheads forming the boundaries of the main vertical zones above the bulkhead deck shall be in line with watertight sub-division bulkheads situated immediately below the bulkhead deck.
- (c) Such bulkheads shall extend from deck to deck and to the shell or other boundaries.
- (d) On ships designed for special purposes, such as automobile or railroad car ferries, where installation of such bulkheads would defeat the purpose for which the ship is intended, equivalent means for controlling and limiting a fire shall be substituted and specifically approved by the Administration.

Regulation 37. Openings in 'A' Class Divisions

- (a) Where 'A' Class divisions are pierced for the passage of electric cables, pipes, trunks, ducts, etc., for girders, beams or other structures, arrangements shall be made to ensure that the fire resistance is not impaired.
- (b) Where of necessity, a duct passes through a main vertical zone bulkhead, a fail-safe automatic closing fire damper shall be fitted adjacent to the bulkhead. The damper shall also be capable of being manually closed from both sides of the bulkhead. The operating position shall be readily accessible and be marked in red light-reflecting colour. The duct between the bulkhead and the damper shall be of steel or other equivalent material and, if necessary, to an insulating standard such as to comply with paragraph (a) of this Regulation. The damper shall be fitted on at least one side of the bulkhead with a visible indicator showing if the damper is in the open position.
- (c) Except for hatches between cargo, store, and baggage spaces, and between such spaces and the weather decks, all openings shall be provided with permanently attached means of closing which shall be at least as effective for resisting fires as the divisions in which they are fitted.
- (d) The construction of all doors and door frames in 'A' Class divisions, with the means of securing them when closed, shall provide resistance to fire as well as to the passage of smoke and flame as far as practicable equivalent to that of the bulkheads in which the doors are situated. Watertight doors need not be insulated.
- (e) It shall be possible for each door to be opened from either side of the bulkhead by one person only.
- (f) Fire doors in main vertical zone bulkheads and stairway enclosures, other than power-operated watertight doors and those which are normally locked, shall be of the self-closing type capable of closing against an inclination of 31/2 degrees opposing closure. All such doors, except those that are normally closed, shall be capable of release from a control station, either simultaneously or in groups, and also individually from a position at the door. The release mechanism shall be so designed that the door will automatically close in the event of disruption of the control system; however, approved power-operated watertight doors will be considered acceptable for this purpose. Hold-back hooks, not subject to control station release, will not be permitted. When double swing doors are permitted, they shall have a latch arrangement which is automatically engaged by the operation of the door release system.

Regulation 38. Fire Integrity of 'A' Class Divisions

Where 'A' Class divisions are required under this Part, the Administration, in deciding the amount of insulation to be provided, shall be guided by the provisions of Part B of this Chapter, but may accept a reduction of the amount of insulation below that stipulated by that Part.

Regulation 39. Separation of Accommodation Spaces From Machinery, Cargo and Service Spaces

The boundary bulkheads and decks separating accommodation spaces from machinery, cargo and service spaces shall be constructed of 'A' Class divisions, and these bulkheads and decks shall have an insulation value to the satisfaction of the Administration having regard to the nature of the adjacent spaces.

Regulation 40. Protection of Accommodation and Service Spaces

The accommodation and service spaces shall be protected in accordance with the provisions of either paragraph (a) or (b) of this Regulation.

- (a) (i) Within the accommodation spaces, all enclosure bulkheads other than those required to be of 'A' Class divisions, shall be constructed of 'B' Class divisions of non-combustible materials, which may, however, be faced with combustible materials in accordance with sub-paragraph (iii) of this paragraph.
 - (ii) All corridor bulkheads shall extend from deck to deck. Ventilation openings may be permitted in the doors in 'B' Class bulkheads, preferably in the lower portion. All other enclosure bulkheads shall extend from deck to deck vertically, and to the shell or other boundaries transversely, unless non-combustible ceilings or linings such as will ensure fire integrity are fitted, in which case the bulkheads may terminate at the ceilings or linings.
 - (iii) Except in cargo spaces, mail rooms, baggage rooms, or refrigerated compartments of service spaces, all linings, grounds, ceilings and insulations shall be of non-combustible materials. The total volume of combustible facings, mouldings, decorations and veneers in any accommodation or public space shall not exceed a volume equivalent to 2.54 millimetres (1/10 inch) veneer on the combined area of the walls and ceilings. All exposed surfaces in corridors or stairway enclosures and in concealed or inaccessible spaces shall have low flame-spread characteristics.¹⁷
- (b) (i) All corridor bulkheads in accommodation spaces shall be of steel or be constructed of 'B' Class panels.
 - (ii) A fire detecting system of an approved type shall be installed and so arranged as to detect the presence of fire in all enclosed spaces appropriated to the use or service of passengers or crew (except spaces which afford no substantial fire hazard) and automatically to indicate at one or more points or stations where it can be most quickly observed by officers and crew, the presence or indication of fire and also its location.

¹⁷ Reference is made to Guidelines on the Evaluation of Fire Hazard Properties of Materials, adopted by the Organization by Resolution A.166(ES.IV).

Regulation 41. Deck Coverings¹⁸

Primary deck coverings within accommodation spaces, control stations, stairways and corridors shall be of approved material which will not readily ignite.

Regulation 42. Protection of Stairways and Lifts in Accommodation and Service Spaces

- (a) All stairways and means of escape in accommodation and service spaces shall be of steel or other suitable materials.
- (b) Passenger and service lift trunks, vertical trunks for light and air to passenger spaces, *etc.*, shall be of 'A' Class divisions. Doors shall be of steel or other equivalent material and when closed shall provide fire resistance at least as effective as the trunks in which they are fitted.

Regulation 43. Protection of Control Stations and Store-Rooms

- (a) Control stations shall be separated from the remainder of the ship by 'A' Class bulkheads and decks.
- (b) The boundary bulkheads of baggage rooms, mail rooms, store-rooms, paint and lamp lockers, galleys and similar spaces shall be of 'A' Class divisions. Spaces containing highly inflammable stores shall be so situated as to minimize the danger to passengers or crew in the event of fire.

Regulation 44. Windows and Sidescuttles

- (a) All windows and sidescuttles in bulkheads separating accommodation spaces from weather shall be constructed with frames of steel or other suitable material. The glass shall be retained by a metal glazing bead.
- (b) All windows and sidescuttles in bulkheads within accommodation spaces shall be constructed so as to preserve the integrity requirements of the type of bulkhead in which they are fitted.

Regulation 45. Ventilation Systems

Power ventilation of machinery spaces shall be capable of being stopped from an easily accessible position outside the machinery spaces.

Regulation 46. Details of Construction

- (a) Paints, varnishes and similar preparations having a nitro-cellulose or other highly inflammable base shall not be used in any part of the ship.
- (b) Pipes penetrating 'A' or 'B' Class divisions shall be of a material approved by the Administration having regard to the temperature such divisions are required to withstand. Pipes conveying oil or combustible liquids shall be of a material approved by the Administration having regard to the fire risk. Materials readily rendered ineffective by heat shall not be used for overboard scuppers, sanitary discharges, and other outlets which are close to the water-line and where the failure of the material in the event of fire would give rise to danger of flooding.

¹⁸ Reference is made to Improved Provisional Guidelines on Test Procedures for Primary Deck Coverings, adopted by the Organization by Resolution A.214(VII).

- (c) In spaces containing main propulsion machinery, or oil-fired boilers, or auxiliary internal combustion type machinery of total power output of 746 kW or over, the following measures shall be taken:
- (i) skylights shall be capable of being closed from outside the space;
 - (ii) skylights containing glass panels shall be fitted with external shutters of steel or other equivalent material permanently attached;
 - (iii) any window permitted by the Administration in casings of such spaces shall be of the non-opening type, and shall be fitted with an external shutter of steel or other equivalent material permanently attached; and
 - (iv) in the windows and skylights referred to in sub-paragraphs (i), (ii) and (iii) of this paragraph, wire reinforced glass shall be used.

Regulation 47. Fire Detection Systems and Fire-Extinguishing Equipment

(a) *Patrols and detection*

- (i) An efficient patrol system shall be maintained in all ships so that any outbreak of fire may be promptly detected. Manual fire alarms shall be fitted throughout the passenger and crew accommodation to enable the fire patrol to give an alarm immediately to the navigating bridge or fire control station.
- (ii) An approved fire alarm or fire detecting system shall be provided which will automatically indicate at one or more suitable points or stations the presence or indication of fire and its location in any part of the ship which, in the opinion of the Administration, is not accessible to the patrol system, except where it is shown to the satisfaction of the Administration that the ship is engaged on voyages of such short duration that it would be unreasonable to apply this requirement.
- (iii) The ship, whether new or existing, shall at all times when at sea, or in port (except when out of service), be so manned or equipped as to ensure that any initial fire alarm is immediately received by a responsible member of the crew.

(b) *Fire pumps and fire main system*

The ship shall be provided with fire pumps, fire main system, hydrants and hoses complying with Regulation 5 of this Chapter and with the following requirements:

- (i) A ship of 4,000 tons gross tonnage and upwards shall be provided with at least three independently driven fire pumps and every ship of less than 4,000 tons gross tonnage with at least two such fire pumps.
- (ii) In a ship of 1,000 tons gross tonnage and upwards, the arrangement of sea connexions, pumps and sources of power for operating them shall be such as to ensure that a fire in any one compartment will not put all the fire pumps out of action.
- (iii) In a ship of less than 1,000 tons gross tonnage the arrangements shall be to the satisfaction of the Administration.

(c) *Fire hydrants, hoses and nozzles*

- (i) The ship shall be provided with such number of fire hoses as the Administration may deem sufficient. There shall be at least one fire hose for each of the hydrants required by paragraph (d) of Regulation 5 of this Chapter and these hoses shall be used only for the purposes of extinguishing fires or testing the fire-extinguishing apparatus at fire drills and surveys.
- (ii) In accommodation, service and machinery spaces, the number and position of hydrants shall be such that the requirements of paragraph (d) of Regulation 5 of this Chapter may be complied with when all watertight doors and all doors in main vertical zone bulkheads are closed.
- (iii) The arrangements shall be such that at least two jets of water can reach any part of any cargo space when empty.
- (iv) All required hydrants in the machinery spaces of ships with oil-fired boilers or internal combustion type propelling machinery shall be fitted with hoses having nozzles as required in paragraph (g) of Regulation 5 of this Chapter.

(d) *International shore connexion*

- (i) A ship of 1,000 tons gross tonnage and upwards shall be provided with at least one international shore connexion, complying with paragraph (h) of Regulation 5 of this Chapter.
- (ii) Facilities shall be available enabling such a connexion to be used on either side of the ship.

(e) *Portable fire extinguishers in accommodation and service spaces*

The ship shall be provided in accommodation and service spaces with such approved portable fire extinguishers as the Administration may deem to be appropriate and sufficient.

(f) *Fixed fire-extinguishing arrangements in cargo spaces*

- (i) The cargo spaces of ships of 1,000 tons gross tonnage and upwards shall be protected by a fixed gas fire-extinguishing system complying with Regulation 8 of this Chapter.
- (ii) Where it is shown to the satisfaction of the Administration that a ship is engaged on voyages of such short duration that it would be unreasonable to apply the requirements of subparagraph (i) of this paragraph and also in ships of less than 1,000 tons gross tonnage, the arrangements in cargo spaces shall be to the satisfaction of the Administration.

(g) *Fire-extinguishing appliances in boiler rooms, etc.*

Where main or auxiliary oil-fired boilers are situated, or in spaces containing oil fuel units or settling tanks, a ship shall be provided with the following arrangements:

- (i) There shall be any one of the following fixed fire-extinguishing installations:
 - (1) a pressure water-spraying system complying with Regulation 11 of this Chapter;
 - (2) a gas fire-extinguishing installation complying with Regulation 8 of this Chapter;

- (3) a fixed froth installation complying with Regulation 9 of this Chapter. (The Administration may require fixed or mobile arrangements by pressure water or froth spraying to fight fire above the floor plates.)

In each case if the engine and boiler rooms are not entirely separate, or if fuel oil can drain from the boiler room into the engine room bilges, the combined engine and boiler rooms shall be considered as one compartment.

- (ii) There shall be at least two approved portable extinguishers discharging froth or other approved medium suitable for extinguishing oil fires, in each firing space in each boiler room and each space in which a part of the oil fuel installation is situated. There shall be not less than one approved froth type extinguisher of at least 136 litres (30 gallons) capacity or equivalent in each boiler room. These extinguishers shall be provided with hoses on reels suitable for reaching any part of the boiler room and spaces containing any part of the oil fuel installations.
- (iii) In each firing space there shall be a receptacle containing sand, sawdust impregnated with soda or other approved dry material, in such quantity as may be required by the Administration. Alternatively an approved portable extinguisher may be substituted therefor.

(h) *Fire-fighting appliances in spaces containing internal combustion type machinery*

Where internal combustion type engines are used, either for main propulsion or for auxiliary purposes associated with a total power output of not less than 746 kW, a ship shall be provided with the following arrangements:

- (i) there shall be one of the fixed arrangements required by sub-paragraph (g)(i) of this Regulation;
- (ii) there shall be in each engine space one approved froth-type extinguisher of not less than 45 litres (10 gallons) capacity or equivalent and also one approved portable froth-type extinguisher for each 746 kW of engine power output or part thereof; but the total number of portable extinguishers so supplied shall be not less than two and need not exceed six.

(i) *Fire-fighting arrangements in spaces containing steam turbines and not requiring any fixed installation*

The Administration shall give special consideration to the fire-extinguishing arrangements to be provided in spaces containing steam turbines which are separated from boiler rooms by watertight bulkheads.

(j) *Fireman's outfits and personal equipment*

- (i) The minimum number of fireman's outfits complying with the requirements of Regulation 14 of this Chapter, and of additional sets of personal equipment, each such set comprising the items stipulated in sub-paragraphs(a)(i), (ii) and (iii) of that Regulation, to be carried, shall be as follows:

(1) two fireman's outfits; and in addition

(2) for every 80 metres (262 feet) or part thereof, of the aggregate of the lengths of all passenger spaces and service spaces on the deck which carries such spaces or, if there is more than one such deck, on the deck which has the largest aggregate of such

lengths, two fireman's outfits and two sets of personal equipment, each such set comprising the items stipulated in Regulation 14(a)(i), (ii) and (iii) of this Chapter.

- (ii) For each fireman's outfit which includes a self-contained breathing apparatus as provided in paragraph (b) of Regulation 14 of this Chapter, spare charges shall be carried on a scale approved by the Administration.
- (iii) Fireman's outfits and sets of personal equipment shall be stored in widely separated positions ready for use. At least two fireman's outfits and one set of personal equipment shall be available at any one position.

Regulation 48. Means of Escape

- (a) In and from all passenger and crew spaces and spaces in which crews are normally employed, other than machinery spaces, stairways and ladderways shall be arranged so as to provide ready means of escape to the lifeboat embarkation deck. In particular the following precautions shall be complied with:
 - (i) below the bulkhead deck, two means of escape, at least one of which shall be independent of watertight doors, shall be provided for each watertight compartment or similarly restricted space or group of spaces. One of these means of escape may be dispensed with by the Administration, due regard being paid to the nature and the location of spaces concerned, and to the number of persons who normally might be quartered or employed there;
 - (ii) above the bulkhead deck, there shall be at least two practical means of escape from each main vertical zone or similarly restricted space or group of spaces at least one of which shall give access to a stairway forming a vertical escape; and
 - (iii) at least one of the means of escape shall be by means of a readily accessible enclosed stairway, which shall provide as far as practicable continuous fire shelter from the level of its origin to the lifeboat embarkation deck. The width, number and continuity of the stairways shall be to the satisfaction of the Administration.
- (b) In machinery spaces, two means of escape, one of which may be a watertight door, shall be provided from each engine room, shaft tunnel and boiler room. In machinery spaces, where no watertight door is available, the two means of escape shall be formed by two sets of steel ladders as widely separated as possible leading to doors in the casing similarly separated and from which access is provided to the embarkation deck. In the case of ships of less than 2,000 tons gross tonnage, the Administration may dispense with this requirement, due regard being paid to the width and the disposition of the casing.

Regulation 49. Oil Fuel Used for Internal Combustion Engines

No internal combustion engine shall be used for any fixed installation in a ship if its fuel has a flashpoint of 43°C (110°F) or less (closed cup test) as determined by an approved flashpoint apparatus.

Regulation 50. Special Arrangements in Machinery Spaces

- (a) Means shall be provided for stopping ventilating fans serving machinery and cargo spaces and for closing all doorways, ventilators, annular spaces around funnels and other openings to such spaces. These means shall be capable of being operated from outside such spaces in case of fire.

- (b) Machinery driving forced and induced draught fans, oil fuel transfer pumps, oil fuel unit pumps and other similar fuel pumps shall be fitted with remote controls situated outside the space concerned so that they may be stopped in the event of a fire arising in the space in which they are located.
- (c) Every oil fuel suction pipe from a storage, settling or daily service tank situated above the double bottom shall be fitted with a cock or valve capable of being closed from outside the space concerned in the event of a fire arising in the space in which such tanks are situated. In the special case of deep tanks situated in any shaft or pipe tunnel, valves on the tanks shall be fitted but control in event of fire may be effected by means of an additional valve on the pipeline or lines outside the tunnel or tunnels.

PART D

FIRE SAFETY MEASURES FOR CARGO SHIPS¹⁹

Regulation 51. General Requirements for Cargo Ships of 4,000 Tons Gross Tonnage and Upwards Other than Tankers Covered by Part E of This Chapter

- (a) The hull, superstructure, structural bulkheads, decks and deckhouses shall be constructed of steel, except where the Administration may sanction the use of other suitable material in special cases, having in mind the risk of fire.
- (b) In accommodation spaces, the corridor bulkheads shall be of steel or be constructed of 'B' Class panels.
- (c) Deck coverings within accommodation spaces on the decks forming the crown of machinery and cargo spaces shall be of a type which will not readily ignite.²⁰
- (d) Interior stairways below the weather deck shall be of steel or other suitable material. Crew lift trunks within accommodation shall be of steel or equivalent material.
- (e) Bulkheads of galleys, paint stores, lamp rooms, boatswain's stores when adjacent to accommodation spaces and emergency generator rooms if any, shall be of steel or equivalent material.
- (f) In accommodation and machinery spaces, paints, varnishes and similar preparations having a nitro-cellulose or other highly inflammable base shall not be used.
- (g) Pipes conveying oil or combustible liquids shall be of a material approved by the Administration having regard to the fire risk. Materials readily rendered ineffective by heat shall not be used for overboard scuppers, sanitary discharges, and other outlets which are close to the water-line and where the failure of the material in the event of fire would give rise to danger of flooding.
- (h) Power ventilation of machinery spaces shall be capable of being stopped from an easily accessible position outside the machinery spaces.

¹⁹ Reference is made to Recommendation on Safety Measures for Periodically Unattended Machinery Spaces of Cargo Ships additional to those normally considered necessary for an Attended Machinery Space, adopted by the Organization by Resolution A.211(VH).

²⁰ Reference is made to Improved Provisional Guidelines on Test Procedures for Primary Deck Coverings, adopted by the Organization by Resolution A.214(VII).

Regulation 52. Fire-Extinguishing Systems and Equipment**(a) *Application***

Where ships have a lower gross tonnage than those quoted in this Regulation, the arrangements for the items covered in this Regulation shall be to the satisfaction of the Administration.

(b) *Fire pumps and fire main system*

The ship shall be provided with fire pumps, fire main system, hydrants and hoses complying with Regulation 5 of this Chapter and with the following requirements:

- (i) A ship of 1,000 tons gross tonnage and upwards shall be provided with two independently driven power pumps.
- (ii) In a ship of 1,000 tons gross tonnage and upwards if a fire in any one compartment could put all the pumps out of action, there must be an alternative means of providing water for fire fighting. In a ship of 2,000 tons gross tonnage and upwards this alternative means shall be a fixed emergency pump independently driven. This emergency pump shall be capable of supplying two jets of water to the satisfaction of the Administration.

(c) *Fire hydrants, hoses and nozzles*

- (i) In a ship of 1,000 tons gross tonnage and upwards the number of fire hoses to be provided, each complete with couplings and nozzles, shall be one for each 30 metres (100 feet) length of the ship and one spare but in no case less than five in all. This number does not include any hoses required in any engine or boiler room. The Administration may increase the number of the hoses required so as to ensure that hoses in sufficient number are available and accessible at all times, having regard to the type of the ship and the nature of the trade on which the ship is employed.
- (ii) In accommodation, service and machinery spaces, the number and position of hydrants shall be such as to comply with the requirements of paragraph (d) of Regulation 5 of this Chapter.
- (iii) In a ship the arrangements shall be such that at least two jets of water can reach any part of any cargo space when empty.
- (iv) All required hydrants in the machinery spaces of ships with oil-fired boilers or internal combustion type propelling machinery shall be fitted with hoses having nozzles as required in paragraph (g) of Regulation 5 of this Chapter.

(d) *International shore connexion*

- (i) A ship of 1,000 tons gross tonnage and upwards shall be provided with at least one international shore connexion, complying with paragraph (h) of Regulation 5 of this Chapter.
- (ii) Facilities shall be available enabling such a connexion to be used on either side of the ship.

(e) *Portable fire extinguishers in accommodation and service spaces*

The ship shall be provided in accommodation and service spaces with such approved portable fire extinguishers as the Administration may deem to be appropriate and sufficient; in any case, their number shall not be less than five for ships of 1,000 tons gross tonnage and upwards.

(f) *Fixed fire-extinguishing arrangements in cargo spaces*

- (i) Cargo spaces of ships of 2,000 tons gross tonnage and upwards shall be protected by a fixed fire-extinguishing system complying with Regulation 8 of this Chapter.
- (ii) The Administration may exempt from the requirements of sub-paragraph (i) of this paragraph the cargo holds of any ship (other than the tanks of a tanker):
 - (1) if they are provided with steel hatch covers and effective means of closing all ventilators and other openings leading to the holds;
 - (2) if the ship is constructed and intended solely for carrying such cargoes as ore, coal or grain; or
 - (3) where it is shown to the satisfaction of the Administration that the ship is engaged on voyages of such short duration that it would be unreasonable to apply the requirement.
- (iii) Every ship in addition to complying with the requirements of this Regulation shall, while carrying explosives of such nature or in such quantity as are not permitted to be carried in passenger ships under Regulation 7 of Chapter VII of this Convention comply with the following requirements:
 - (1) Steam shall not be used in any compartment containing explosives. For the purpose of this sub-paragraph, "compartment" means all spaces contained between two adjacent permanent bulkheads and includes the lower hold and all cargo spaces above it.
 - (2) In addition, in each compartment containing explosives and in adjacent cargo compartments, there shall be provided a smoke- or fire-detection system in each cargo space.

(g) *Fire-extinguishing appliances in boiler rooms, etc.*

Where main or auxiliary oil-fired boilers are situated, or in spaces containing oil fuel units or settling tanks, a ship of 1,000 tons gross tonnage and upwards shall be provided with the following arrangements:

- (i) There shall be any one of the following fixed fire-extinguishing installations:
 - (1) A pressure water-spraying system complying with Regulation 11 of this Chapter.
 - (2) A fire-extinguishing installation complying with Regulation 8 of this Chapter.
 - (3) A fixed froth installation complying with Regulation 9 of this Chapter. (The Administration may require fixed or mobile arrangements by pressure water or froth spraying to fight fire above the floor plates.)

In each case if the engine and boiler rooms are not entirely separate, or if fuel oil can drain from the boiler room into the engine room bilges, the combined engine and boiler rooms shall be considered as one compartment.

- (ii) There shall be at least two approved portable extinguishers discharging froth or other approved medium suitable for extinguishing oil fires in each firing space in each boiler room and each space in which a part of the oil fuel installation is situated. In addition, there shall be at least one extinguisher of the same description with a capacity of 9 litres (2 gallons) for each burner, provided that the total capacity of the additional extinguisher or extinguishers need not exceed 45 litres (10 gallons) for any one boiler room.
- (iii) In each firing space there shall be a receptacle containing sand, sawdust impregnated with soda, or other approved dry material in such quantity as may be required by the Administration. Alternatively an approved portable extinguisher may be substituted therefor.

(h) *Fire-fighting appliances in spaces containing internal combustion type machinery*

Where internal combustion type engines are used, either for main propulsion machinery, or for auxiliary purposes associated with a total power output of not less than 746 kW, a ship of 1,000 tons gross tonnage and upwards shall be provided with the following arrangements:

- (i) There shall be one of the fixed arrangements required by sub-paragraph (g)(i) of this Regulation.
- (ii) There shall be in each engine space one approved froth-type extinguisher of not less than 45 litres (10 gallons) capacity or equivalent and also one approved portable froth extinguisher for each 746 kW of engine power output or part thereof; but the total number of portable extinguishers so supplied shall be not less than two and need not exceed six.

(i) *Fire-fighting arrangements in spaces containing steam turbines and not requiring any fixed installation*

The Administration shall give special consideration to the fire-extinguishing arrangements to be provided in spaces containing steam turbines which are separated from boiler rooms by watertight bulkheads.

(j) *Fireman's outfits and personal equipment*

- (i) The ship, whether new or existing, shall carry at least two fireman's outfits complying with the requirements of Regulation 14 of this Chapter. Furthermore, Administrations may require in large ships additional sets of personal equipment and in tankers and special ships such as factory ships additional fireman's outfits.
- (ii) For each fireman 's outfit which includes a self-contained breathing apparatus as provided in paragraph (b) of Regulation 14 of this Chapter, spare charges shall be carried on a scale approved by the Administration.
- (iii) The fireman's outfits and personal equipment shall be stored so as to be easily accessible and ready for use and, where more than one fireman's outfit and set of personal equipment are carried, they shall be stored in widely separated positions.

Regulation 53. Means of Escape

- (a) In and from all crew and passenger spaces and spaces in which crew are normally employed, other than machinery spaces, stairways and ladders shall be arranged so as to provide ready means of escape to the lifeboat embarkation deck.

- (b) In machinery spaces, two means of escape, one of which may be a watertight door, shall be provided from each engine room, shaft tunnel and boiler room. In machinery spaces, where no watertight door is available, the two means of escape shall be formed by two sets of steel ladders as widely separated as possible leading to doors in the casing similarly separated and from which access is provided to the embarkation deck. In the case of ships of less than 2,000 tons gross tonnage, the Administration may dispense with this requirement, due regard being paid to the width and the disposition of the casing.

Regulation 54. Special Arrangements in Machinery Spaces

- (a) Means shall be provided for stopping ventilating fans serving machinery and cargo spaces and for closing all doorways, ventilators, annular spaces around funnels and other openings to such spaces. These means shall be capable of being operated from outside such spaces in case of fire.
- (b) Machinery driving forced and induced draught fans, oil fuel transfer pumps, oil fuel unit pumps and other similar fuel pumps shall be fitted with remote controls situated outside the space concerned so that they may be stopped in the event of a fire arising in the space in which they are located.
- (c) Every oil fuel suction pipe from a storage, settling or daily service tank situated above the double bottom shall be fitted with a cock or valve capable of being closed from outside the space concerned in the event of a fire arising in the space in which such tanks are situated. In the special case of deep tanks situated in any shaft or pipe tunnel, valves on the tanks shall be fitted but control in event of fire may be effected by means of an additional valve on the pipeline or lines outside the tunnel or tunnels.

PART E FIRE SAFETY MEASURES FOR TANKERS

Regulation 55. Application

- (a) This Part shall apply to all new tankers carrying crude oil and petroleum products having a flashpoint not exceeding 60°C (140°F) (closed cup test) as determined by an approved flashpoint apparatus and whose Reid vapour pressure is below that of atmospheric pressure, and other liquid products having a similar fire hazard.
- (b) In addition, all ships covered by this Part shall comply with the requirements of Regulations 52, 53 and 54 of this Chapter, except that paragraph (f) of Regulation 52 need not apply to tankers complying with Regulation 60 of this Chapter.
- (c) Where cargoes other than those referred to in paragraph (a) of this Regulation which introduce additional fire hazards are intended to be carried, additional safety measures shall be required to the satisfaction of the Administration.
- (d) Combination carriers shall not carry solid cargoes unless all cargo tanks are empty of oil and gas freed or unless, in each case, the Administration is satisfied with the arrangements provided.

Regulation 56. Location and Separation of Spaces

- (a) Machinery spaces of Category A shall be positioned aft of cargo tanks and slop tanks and shall be isolated from them by a cofferdam, cargo pump room or oil fuel bunker tank; they shall also be situated aft of such cargo pump rooms and cofferdams, but not necessarily aft of the oil fuel

bunker tanks. However, the lower portion of the pump room may be recessed into such spaces to accommodate pumps provided the deck head of the recess is in general not more than one-third of the moulded depth above the keel except that in the case of ships of not more than 25,000 metric tons deadweight, where it can be demonstrated that for reasons of access and satisfactory piping arrangements this is impracticable, the Administration may permit a recess in excess of such height, but not exceeding one half of the moulded depth above the keel.

- (b) Accommodation spaces, main cargo control stations, control stations and service spaces shall be positioned aft of all cargo tanks, slop tanks, cargo pump rooms and cofferdams which isolate cargo or slop tanks from machinery spaces of Category A. Any common bulkhead separating a cargo pump room, including the pump room entrance, from accommodation and service spaces and control stations shall be constructed to "A-60" Class. Where deemed necessary, accommodation spaces, control stations, machinery spaces other than those of Category A and service spaces may be permitted forward of all cargo tanks, slop tanks, cargo pump rooms and cofferdams subject to an equivalent standard of safety and appropriate availability of fire-extinguishing arrangements being provided to the satisfaction of the Administration.
- (c) Where the fitting of a navigation position above the cargo tank area is shown to be necessary it shall be for navigation purposes only and it shall be separated from the cargo tank deck by means of an open space with a height of at least 2 metres. The fire protection of such navigation position shall in addition be as required for control spaces as set forth in paragraphs (a) and (b) of Regulation 57 and other provisions as applicable of this Part.
- (d) Means shall be provided to keep deck spills away from the accommodation and service areas. This may be accomplished by provision of a permanent continuous coaming of a suitable height extending from side to side. Special consideration shall be given to the arrangements associated with stern loading.
- (e) Exterior boundaries of superstructures and deckhouses enclosing accommodation and service spaces and including any overhanging decks which support such accommodation, shall be insulated to "A-60" Class for the whole of the portions which face cargo oil tanks and for 3 metres aft of the front boundary. In the case of the sides of these superstructures and deckhouses, such insulation shall be carried as high as is deemed necessary by the Administration.
- (f) In boundaries, facing cargo tanks, of superstructures and deckhouses containing accommodation and service spaces the following provisions shall apply:
 - (i) No doors shall be permitted in such boundaries, except that doors to those spaces not having access to accommodation and service spaces, such as cargo control stations, provision rooms, and store-rooms may be permitted by the Administration. Where such doors are fitted, the boundaries of the space shall be insulated to "A-60" Class. Bolted plates for removal of machinery may be fitted in such boundaries.
 - (ii) Portlights in such boundaries shall be of a fixed (non-opening) type. Pilot house windows may be non-fixed (opening).
 - (iii) Portlights in the first tier on the main deck shall be fitted with inside covers of steel or equivalent material.

The requirements of this paragraph, where applicable, except in the case of access to the navigating bridge spaces, shall also be applied to the boundaries of the superstructures and deckhouses for a distance of 5 metres measured longitudinally from the forward end of such structures.

Regulation 57. Construction

- (a) (i) The hull, superstructure, structural bulkheads, decks and deckhouses shall be constructed of steel or other equivalent material.
- (ii) Bulkheads between cargo pump rooms, including their trunks and machinery spaces of Category A shall be 'A' Class and shall have no penetrations which are less than "A-0" Class or equivalent in all respects, other than the cargo pump shaft glands and similar glanded penetrations.
- (iii) Bulkheads and decks forming divisions separating machinery spaces of Category A and cargo pump rooms, including their trunks, respectively, from the accommodation and service spaces shall be of "A-60" Class. Such bulkheads and decks and any boundaries of machinery spaces of Category A and cargo pump rooms shall not be pierced for windows or portlights.
- (iv) The requirements of sub-paragraphs (ii) and (iii) of this paragraph, however, do not preclude the installation of permanent approved gas-tight lighting enclosures for illuminating the pump rooms provided that they are of adequate strength and maintain the integrity and gas-tightness of the bulkhead as 'A' Class. Further, it does not preclude the use of windows in a control room located entirely within a machinery space.
- (v) Control stations shall be separated from adjacent enclosed spaces by means of 'A' Class bulkheads and decks. The insulation of these control station boundaries shall be to the satisfaction of the Administration having in mind the risk of fire in adjacent spaces.
- (vi) Casing doors in machinery spaces of Category A shall be self-closing and comply with the related provisions of sub-paragraph (b)(vii) of this Regulation.
- (vii) The surface of the insulation on interior boundaries of machinery spaces of Category A shall be impervious to oil and oil vapours.
- (viii) Primary deck coverings, if applied, shall be of approved materials which will not readily ignite.²¹
- (ix) Interior stairways shall be of steel or other suitable material.
- (x) When adjacent to accommodation spaces, bulkheads of galleys, paint stores, lamp rooms and boatswain's stores shall be of steel or equivalent material.
- (xi) Paints, varnishes and other finishes used on exposed interior surfaces shall not be of a nature to offer an undue fire hazard in the judgement of the Administration and shall not be capable of producing excessive quantities of smoke or other toxic properties.

²¹ Reference is made to Improved Provisional Guidelines on Test Procedures for Primary Deck Coverings, adopted by the Organization by Resolution A.214(VII).

- (xii) Pipes conveying oil or combustible liquids shall be of a material approved by the Administration having regard to the fire risk. Materials readily rendered ineffective by heat shall not be used for overboard scuppers, sanitary discharges, and other outlets which are close to the water-line and where the failure of the material in the event of fire would give rise to danger of flooding.
 - (xiii) Power ventilation of machinery spaces shall be capable of being stopped from an easily accessible position outside the machinery spaces.
 - (xiv) Skylights to machinery spaces of Category A and cargo pump rooms shall comply with the provisions of sub-paragraph (a)(iii) of this Regulation in respect of windows and portlights and in addition shall be so arranged as to be capable of being readily closed from outside the spaces which they service.
- (b) Within the accommodation and service spaces and control stations the following conditions shall apply:
- (i) Corridor bulkheads including doors shall be of 'A' or 'B' Class divisions extending from deck to deck. Where continuous 'B' Class ceilings and/or linings are fitted on both sides of the bulkhead, the bulkhead may terminate at the continuous ceiling or lining. Doors of cabins and public spaces in such bulkheads may have a louvre in the lower half.
 - (ii) Air spaces enclosed behind ceilings, panellings, or linings shall be divided by close fitting draught stops spaced not more than 14 metres apart.
 - (iii) Ceilings, linings, bulkheads and insulation except for insulation in refrigerated compartments shall be of non-combustible material. Vapour barriers and adhesives used in conjunction with insulation, as well as insulation of pipe fittings for cold service systems need not be non-combustible, but they shall be kept to the minimum quantity practicable and their exposed surfaces shall have resistance to propagation of flame to the satisfaction of the Administration.
 - (iv) The framing, including grounds and the joint pieces of bulkheads, linings, ceilings and draught stops, if fitted, shall be of non-combustible material.
 - (v) All exposed surfaces in corridors and stairway enclosures and surfaces in concealed or inaccessible spaces shall have low flame-spread characteristics.²²
 - (vi) Bulkheads, linings and ceilings may have combustible veneer, provided that such veneer shall not exceed 2 millimetres within any such space except corridors, stairway enclosures and control stations where it shall not exceed 1.5 millimetres.
 - (vii) Stairways which penetrate only a single deck shall be protected at least at one level by 'A' or 'B' Class divisions and self-closing doors so as to limit the rapid spread of fire from one deck to another. Crew lift trunks shall be of 'A' Class divisions. Stairways and lift trunks which penetrate more than a single deck shall be surrounded by 'A' Class divisions and protected by self-closing steel doors at all levels. Self-closing doors shall not be fitted with hold-back hooks. However, hold-back arrangements fitted with remote release fittings of the fail-safe type may be utilized.

²² Reference is made to Guidelines on Evaluation of Fire Hazard Properties of Materials, adopted by the Organization by Resolution A.166(ES.IV).

- (c) Ducts provided for ventilation of machinery spaces of Category 'A' shall not in general pass through accommodation and service spaces or control stations, except that the Administration may permit relaxation from this requirement provided that:
- (i) the ducts are constructed of steel and each is insulated to "A-60" Class; or
 - (ii) the ducts are constructed of steel and are fitted with an automatic fire damper close to the boundary penetrated and are insulated to "A-60" Class from the machinery space of Category A to a point at least 5 metres beyond the fire damper.
- (d) Ducts provided for ventilation of accommodation and service spaces or control stations shall not in general pass through machinery spaces of Category A except that the Administration may permit relaxation from this requirement provided that ducts are constructed of steel and an automatic fire damper is fitted close to the boundaries penetrated.

Regulation 58. Ventilation

- (a) The arrangement and positioning of openings in the cargo tank deck from which gas emission can occur shall be such as to minimize the possibility of gas being admitted to enclosed spaces containing a source of ignition, or collecting in the vicinity of deck machinery and equipment which may constitute an ignition hazard. In every case the height of the outlet above the deck and the discharge velocity of the gas shall be considered in conjunction with the distance of any outlet from any deckhouse opening or source of ignition.
- (b) The arrangement of ventilation inlets and outlets and other deckhouse and superstructure boundary space openings shall be such as to complement the provisions of paragraph (a) of this Regulation. Such vents especially for machinery spaces shall be situated as far aft as practicable. Due consideration in this regard should be given when the ship is equipped to load or discharge at the stern. Sources of ignition such as electrical equipment shall be so arranged as to avoid an explosion hazard.
- (c) Cargo pump rooms shall be mechanically ventilated and discharges from the exhaust fans shall be led to a safe place on the open deck. The ventilation of these rooms shall have sufficient capacity to minimize the possibility of accumulation of inflammable vapours. The number of changes of air shall be at least 20 times per hour, based upon the gross volume of the space. The air ducts shall be arranged so that all of the space is effectively ventilated. The ventilation shall be of the suction type.

Regulation 59. Means of Escape

In addition to the requirements of paragraph (a) of Regulation 53 of this Chapter, consideration shall be given by the Administration to the availability of emergency means of escape for personnel from each cabin.

Regulation 60. Cargo Tank Protection

- (a) For tankers of 100,000 metric tons deadweight and upwards and combination carriers of 50,000 metric tons deadweight and upwards, the protection of the cargo tanks deck area and cargo tanks shall be achieved by a fixed deck froth system and a fixed inert gas system in accordance with the requirements of Regulations 61 and 62 of this Part except that in lieu of the above installations the Administration, after having given consideration to the ship arrangement and equipment, may accept other combinations of fixed installations if they afford protection equivalent to the above, in accordance with Regulation 5 of Chapter I of this Convention.

- (b) To be considered equivalent, the system proposed in lieu of the deck froth system shall:
- (i) be capable of extinguishing spill fires and also preclude ignition of spilled oil not yet ignited; and
 - (ii) be capable of combating fires in ruptured tanks.
- (c) To be considered equivalent, the system proposed in lieu of the fixed inert gas system shall:
- (i) be capable of preventing dangerous accumulations of explosive mixtures in intact cargo tanks during normal service throughout the ballast voyage and necessary in-tank operations; and
 - (ii) be so designed as to minimize the risk of ignition from the generation of static electricity by the system itself.
- (d) In tankers of less than 100,000 metric tons deadweight and combination carriers of less than 50,000 metric tons deadweight the Administration, in applying the requirements of paragraph (f) of Regulation 52 of this Chapter, may accept a froth system, capable of discharging froth internally or externally, to the tanks. The details of such installation shall be to the satisfaction of the Administration.

Regulation 61. Fixed Deck Froth System

The fixed deck froth system referred to in paragraph (a) of Regulation 60 of this Chapter shall be designed as follows:

- (a) The arrangements for providing froth shall be capable of delivering froth to the entire cargo tank area as well as into any cargo tank, the deck of which has been ruptured.
- (b) The system shall be capable of simple and rapid operation. The main control station for the system shall be suitably located outside of the cargo tank area, adjacent to the accommodation spaces and readily accessible and operable in the event of fire in the areas protected.
- (c) The rate of supply of froth solution shall be not less than the greater of the following:
 - (i) 0.6 litres per minute per square metre of the cargo deck area, where cargo deck area means the maximum breadth of the ship times the total longitudinal extent of the cargo tank spaces, or
 - (ii) 6 litres per minute per square metre of the horizontal sectional area of the single tank having the largest such area.

Sufficient froth concentrate shall be supplied to ensure at least 20 minutes of froth generation when using solution rates stipulated in sub-paragraph (i) or (ii) of this paragraph, whichever is the greater. The froth expansion ratio (i.e. the ratio of the volume of froth produced to the volume of the mixture of water and froth-making concentrate supplied) shall not generally exceed 12 to 1. Where systems essentially produce low expansion froth but at an expansion ratio slightly in excess of 12 to 1, the quantity of froth solution available shall be calculated as for 12 to 1 expansion ratio systems. When medium expansion ratio froth (between 50 to 1 and 150 to 1 expansion ratio) is employed the application rate of the froth and the capacity of a monitor installation shall be to the satisfaction of the Administration.

- (d) Froth from the fixed froth system shall be supplied by means of monitors and froth applicators. At least 50 per cent of the required froth rate shall be delivered from each monitor.
- (e) (i) The number and position of monitors shall be such as to comply with paragraph (a) of this Regulation. The capacity of any monitor in litres per minute of froth solution shall be at least three times the deck area in square metres protected by that monitor, such area being entirely forward of the monitor.
 - (ii) The distance from the monitor to the farthest extremity of the protected area forward of that monitor shall not be more than 75 per cent of the monitor throw in still air conditions.
- (f) A monitor and hose connexion for a froth applicator shall be situated both port and starboard at the poop front or accommodation spaces facing the cargo deck. Applicators shall be provided for flexibility of action during fire-fighting operations and to cover areas screened from the monitors.
- (g) Valves shall be provided in both the froth main and the fire main immediately forward of every monitor position to isolate damaged sections of these mains.
- (h) Operation of a deck froth system at its required output shall permit the simultaneous use of the minimum required number of jets of water at the required pressure from the fire main.

Regulation 62. Inert Gas System

The inert gas system referred to in paragraph (a) of Regulation 60 of this Chapter shall be capable of providing on demand a gas or mixture of gases to the cargo tanks so deficient in oxygen that the atmosphere within a tank may be rendered inert, i.e. incapable of propagating flame. Such a system shall satisfy the following conditions:

- (a) The need for fresh air to enter a tank during normal operations shall be eliminated, except when preparing a tank for entry by personnel.
- (b) Empty tanks shall be capable of being purged with inert gas to reduce the hydrocarbon content of a tank after discharge of cargo.
- (c) The washing of tanks shall be capable of being carried out in an inert atmosphere.
- (d) During cargo discharge, the system shall be such as to ensure that the volume of gas referred to in paragraph (f) of this Regulation is available. At other times sufficient gas to ensure compliance with paragraph (g) of this Regulation shall be continuously available.
- (e) Suitable means for purging the tanks with fresh air as well as with inert gas shall be provided.
- (f) The system shall be capable of supplying inert gas at a rate of at least 125 per cent of the maximum rated capacity of the cargo pumps.
- (g) Under normal running conditions, when tanks are being filled or have been filled with inert gas, a positive pressure shall be capable of being maintained at the tank.

- (h) Exhaust gas outlets for purging shall be suitably located in the open air and shall be to the same general requirements as prescribed for ventilating outlets of tanks, referred to in paragraph (a) of Regulation 58 of this Chapter.
- (i) A scrubber shall be provided which will effectively cool the gas and remove solids and sulphur combustion products.
- (j) At least two fans (blowers) shall be provided which together shall be capable of delivering at least the amount of gas stipulated in paragraph (f) of this Regulation.
- (k) The oxygen content in the inert gas supply shall not normally exceed 5 per cent by volume.
- (l) Means shall be provided to prevent the return of hydrocarbon gases or vapours from the tanks to the machinery spaces and uptakes and prevent the development of excessive pressure or vacuum. In addition, an effective water lock shall be installed at the scrubber or on deck. Branch piping for inert gas shall be fitted with stop valves or equivalent means of control at every tank. The system shall be so designed as to minimize the risk of ignition from the generation of static electricity.
- (m) Instrumentation shall be fitted for continuously indicating and permanently recording at all times when inert gas is being supplied the pressure and oxygen content of the gas in the inert gas supply main on the discharge side of the fan. Such instrumentation should preferably be placed in the cargo control room if fitted but in any case shall be easily accessible to the officer in charge of cargo operations. Portable instruments suitable for measuring oxygen and hydrocarbon gases or vapour and the necessary tank fittings shall be provided for monitoring the tank contents.
- (n) Means for indicating the temperature and pressure of the inert gas main shall be provided.
- (o) Alarms shall be provided to indicate:
 - (i) high oxygen content of gas in the inert gas main;
 - (ii) low gas pressure in the inert gas main;
 - (iii) low pressure in the supply to the deck water seal, if such equipment is installed;
 - (iv) high temperature of gas in the inert gas main; and
 - (v) low water pressure to the scrubberand automatic shut-downs of the system shall be arranged on predetermined limits being reached in respect of sub-paragraphs (iii), (iv) and (v) of this paragraph.
- (p) The master of any ship equipped with an inert gas system shall be provided with an instruction manual covering operational, safety and occupational health requirements relevant to the system.

Regulation 63. Cargo Pump Room

Each cargo pump room shall be provided with a fixed fire-fighting system operated from a readily accessible position outside the pump room. The system shall use water-spray or another suitable medium satisfactory to the Administration.

Regulation 64. Hose Nozzles

All hose water nozzles provided shall be of an approved dual purpose type (i.e. spray/jet type) incorporating a shut-off.

PART F SPECIAL FIRE SAFETY MEASURES FOR EXISTING PASSENGER SHIPS

(For the purposes of this Part of this Chapter, all references to Regulation ... (1948) mean references to Regulations of Chapter II of the International Convention for the Safety of Life at Sea, 1948, and all references to Regulation ... (1960) mean, unless otherwise stated, references to Regulations of Chapter II of the International Convention for the Safety of Life at Sea, 1960)

Regulation 65. Application

Any passenger ship carrying more than 36 passengers shall at least comply as follows:

- (a) A ship, the keel of which was laid before 19 November 1952, shall comply with the provisions of Regulations 66 to 85 inclusive of this Part.
- (b) A ship, the keel of which was laid on or after 19 November 1952 but before 26 May 1965, shall comply with the provisions of the International Convention for the Safety of Life at Sea, 1948, relating to the fire safety measures applicable in that Convention to new ships and shall also comply with the provisions of Regulations 68(b) and (c), 75, 77(b), 78, 80(b), 81(b) to (g), 84 and 85 of this Part.
- (c) A ship, the keel of which was laid on or after 26 May 1965, but before the present Convention comes into force, shall, unless it complies with Parts A and B of this Chapter, comply with the provisions of the International Convention for the Safety of Life at Sea, 1960 relating to the fire safety measures applicable in that Convention to new ships and shall also comply with Regulations 68(b) and (c), 80(b), 81(b), (c) and (d) and 85 of this Part.

Regulation 66. Structure

The structural components shall be of steel or other suitable material in compliance with Regulation 27 (1948), except that isolated deckhouses containing no accommodation and decks exposed to the weather may be of wood if structural fire protection measures are taken to the satisfaction of the Administration.

Regulation 67. Main Vertical Zones

The ship shall be subdivided by 'A' Class divisions into main vertical zones in compliance with Regulation 28 (1948). Such divisions shall have as far as practicable adequate insulating value, taking into account the nature of the adjacent spaces as provided for in Regulation 26(c)(iv) (1948).

Regulation 68. Openings in Main Vertical Zone Bulkheads

- (a) The ship shall comply substantially with Regulation 29 (1948).
- (b) Fire doors shall be of steel or equivalent material with or without non-combustible insulation.
- (c) In the case of ventilation trunks and ducts having a cross-sectional area of 0.02 square metres (31 square inches) or more which pass through main zone divisions, the following additional provisions shall apply:

- (i) for trunks and ducts having cross-sectional areas between 0.02 square metres (31 square inches) and 0.075 square metres (116 square inches) inclusive, fire dampers shall be of a fail-safe automatic closing type, or such trunks and ducts shall be insulated for at least 457 millimetres (18 inches) on each side of the division to meet the applicable bulkhead requirements;
- (ii) for trunks and ducts having a cross-sectional area exceeding 0.075 square metres (116 square inches), fire dampers shall be of a fail-safe automatic closing type.

Regulation 69. Separation of Accommodation Spaces from Machinery, Cargo and Service Spaces

The ship shall comply with Regulation 31 (1948).

Regulation 70. Application Relative to Methods I, II and III

Each accommodation space and service space in a ship shall comply with all the provisions stipulated in one of the paragraphs (a), (b), (c) or (d) of this Regulation:

- (a) When a ship is being considered for acceptance in the context of Method I, a network of non-combustible 'B' Class bulkheads shall be provided in substantial compliance with Regulation 30(a) (1948) together with maximum use of non-combustible materials in compliance with Regulation 39(a) (1948).
- (b) When a ship is being considered for acceptance in the context of Method II:
 - (i) an automatic sprinkler and fire alarm system shall be provided which shall be in substantial compliance with Regulations 42 and 48 (1948), and
 - (ii) the use of combustible materials of all kinds shall be reduced as far as is reasonable and practicable.
- (c) When a ship is being considered for acceptance in the context of Method III, a network of fire-retarding bulkheads shall be fitted from deck to deck in substantial compliance with Regulation 30(b) (1948), together with an automatic fire detection system in substantial compliance with Regulation 43 (1948). The use of combustible and highly inflammable materials shall be restricted as prescribed in Regulations 39(b) and 40(g) (1948). Departure from the requirements of Regulations 39(b) and 40(g) (1948) may be permitted if a fire patrol is provided at intervals not exceeding 20 minutes.
- (d) When a ship is being considered for acceptance in the context of Method III:
 - (i) additional 'A' Class divisions shall be provided within the accommodation spaces in order to reduce in these spaces the mean length of the main vertical zones to about 20 metres (65.5 feet); and
 - (ii) an automatic fire detection system shall be provided in substantial compliance with Regulation 43 (1948); and
 - (iii) all exposed surfaces, and their coatings; of corridor and cabin bulkheads in accommodation spaces shall be of limited flame-spreading power; and
 - (iv) the use of combustible materials shall be restricted as prescribed in Regulation 39(b) (1948). Departure from the requirements of Regulation 39(b) (1948) may be permitted if a fire patrol is provided at intervals not exceeding 20 minutes; and

- (v) additional non-combustible 'B' Class divisions shall be fitted from deck to deck forming a network of fire-retarding bulkheads within which the area of any compartment, except public spaces, will in general not exceed 300 square metres (3,200 square feet).

Regulation 71. Protection of Vertical Stairways

The stairways shall comply with Regulation 33 (1948) except that, in cases of exceptional difficulty, the Administration may permit the use of non-combustible 'B' Class divisions and doors instead of 'A' Class divisions and doors for stairway enclosures. Moreover, the Administration may permit exceptionally the retention of a wooden stairway subject to its being sprinkler-protected and satisfactorily enclosed.

Regulation 72. Protection of Lifts (Passenger and Service), Vertical Trunks for Light and Air, etc.

The ship shall comply with Regulation 34 (1948).

Regulation 73. Protection of Control Stations

The ship shall comply with Regulation 35 (1948), except however that in cases where the disposition or construction of control stations is such as to preclude full compliance, e.g. timber construction of wheelhouse, the Administration may permit the use of free-standing non-combustible 'B' Class divisions to protect the boundaries of such control stations. In such cases, where spaces immediately below such control stations constitute a significant time hazard, the deck between shall be fully insulated as an 'A' Class division.

Regulation 74. Protection of Store-Rooms, etc.

The ship shall comply with Regulation 36 (1948).

Regulation 75. Windows and Sidescuttles

Skylights of engine and boiler spaces shall be capable of being closed from outside such spaces.

Regulation 76. Ventilation Systems

- (a) All power ventilation, except cargo and machinery space ventilation, shall be fitted with master controls so located outside the machinery space and in readily accessible positions, that it shall not be necessary to go to more than three stations in order to stop all the ventilation fans to spaces other than machinery and cargo spaces. Machinery space ventilation shall be provided with a master control operable from a position outside the machinery space.
- (b) Efficient insulation shall be provided for exhaust ducts from galley ranges where the ducts pass through accommodation spaces.

Regulation 77. Miscellaneous Items

- (a) The ship shall comply with Regulation 40(a), (b) and (f) (1948), except that in Regulation 40(a)(i) (1948), 20 metres (65.5 feet) may be substituted for 13.73 metres (45 feet).
- (b) Fuel pumps shall be fitted with remote controls situated outside the space concerned so that they may be stopped in the event of a fire arising in the space in which they are located.

Regulation 78. Cinematograph Film

Cellulose-nitrate-based film shall not be used in cinematograph installations on board ship.

Regulation 79. Plans

Plans shall be provided in compliance with Regulation 44 (1948).

Regulation 80. Pumps, Fire Main Systems, Hydrants and Hoses

- (a) The provisions of Regulation 45 (1948) shall be complied with.
- (b) Water from the fire main shall, as far as practicable, be immediately available, such as by maintenance of pressure or by remote control of fire pumps, which control shall be easily operable and readily accessible.

Regulation 81. Fire Detection and Extinction Requirements

General

- (a) The requirements of Regulation 50(a) to (o) (1948) inclusive shall be complied with, subject to further provisions of this Regulation.

Patrols, detection and communication system

- (b) Each member of any fire patrol required by this Part shall be trained to be familiar with the arrangements of the ship as well as the location and operation of any equipment he may be called upon to use.
- (c) A special alarm to summon the crew shall be fitted which may be part of the ship 's general alarm system.
- (d) A public address system or other effective means of communication shall also be available throughout the accommodation, public and service spaces.

Machinery and boiler spaces

- (e) The number, type and distribution of fire extinguishers shall comply with paragraphs (g)(ii), (g)(iii) and (h)(ii) of Regulation 64 (1960).

International shore connexion

- (f) The provisions of Regulation 64(d) (1960) shall be complied with.

Fireman's outfits

- (g) The provisions of Regulation 64(j) (1960) shall be complied with.

Regulation 82. Ready availability of fire-fighting appliances

The provisions of Regulation 66 (1960) shall be complied with.

Regulation 83. Means of Escape

The provisions of Regulation 54 (1948) shall be complied with.

Regulation 84. Emergency Source of Electrical Power

The provisions of Regulation 22(a), (b) and (c) (1948) shall be complied with except that the location of the emergency source of electrical power shall be in accordance with the requirements of Regulation 25(a) (1960).

Regulation 85. Practice Musters and Drills

At the fire drills mentioned in Regulation 26 of Chapter III of the International Convention for the Safety of Life at Sea, 1960 each member of the crew shall be required to demonstrate his familiarity with the arrangements and facilities of the ship, his duties, and any equipment he may be called upon to use. Masters shall be required to familiarize and instruct the crews in this regard.

CHAPTER III LIFE-SAVING APPLIANCES, ETC.

Regulation 1. Application

- (a) This Chapter, except where it is otherwise expressly provided, applies as follows to new ships engaged on international voyages:
- Part A - Passenger ships and cargo ships.
 - Part B - Passenger ships.
 - Part C - Cargo ships.
- (b) In the case of existing ships engaged on international voyages, the keels of which were laid or which were at a similar stage of construction on or after the date of coming into force of the International Convention for the Safety of Life at Sea, 1960, the requirements of Chapter III of that Convention applicable to new ships as defined in that Convention shall apply.
- (c) In the case of existing ships engaged on international voyages, the keels of which were laid or which were at a similar stage of construction before the date of coming into force of the International Convention for the Safety of Life at Sea, 1960, and which do not already comply with the provisions of Chapter III of that Convention relating to new ships, the arrangements in each ship shall be considered by the Administration with a view to securing, so far as this is practicable and reasonable, and as early as possible, substantial compliance with the requirements of Chapter III of that Convention. The proviso to sub-paragraph (b)(i) of Regulation 27 of that Chapter may, however, be applied to existing ships referred to in this paragraph only if:
- (i) the provisions of Regulations 4, 8, 14, 18 and 19 and paragraphs (a) and (b) of Regulation 27 of this Chapter are complied with;
 - (ii) the liferafts carried in accordance with the provisions of paragraph (b) of Regulation 27 comply with the requirements of either Regulation 15 or Regulation 16, and of Regulation 17 of this Chapter; and
 - (iii) the total number of persons on board shall not be increased as the result of the provision of liferafts unless the ship fully complies with the provisions of:
 - (1) Part B of Chapter II-1;
 - (2) sub-paragraphs (a)(iii) and (iv) of Regulation 21 or sub-paragraph (a)(iii) of Regulation 48 of Chapter II-2, as applicable; and
 - (3) paragraphs (a), (b), (e) and (f) of Regulation 29 of this Chapter.

PART A GENERAL

(Part A applies to both passenger ships and cargo ships)

Regulation 2. Definitions

For the purpose of this Chapter:

- (a) "Short international voyage" means an international voyage in the course of which a ship is not more than 200 miles from a port or place in which the passengers and crew could be placed in safety, and which does not exceed 600 miles in length between the last port of call in the country in which the voyage begins and the final port of destination.
- (b) "Liferaft" means a liferaft complying with either Regulation 15 or Regulation 16 of this Chapter.
- (c) "Approved launching device" means a device approved by the Administration, capable of launching from the embarkation position a liferaft fully loaded with the number of persons it is permitted to carry and with its equipment.
- (d) "Certificated lifeboatman" means any member of the crew who holds a certificate of efficiency issued under the provisions of Regulation 32 of this Chapter.
- (e) "Buoyant apparatus" means flotation equipment (other than lifeboats, liferafts, lifebuoys and life-jackets) designed to support a specified number of persons who are in the water and of such construction that it retains its shape and properties.

Regulation 3. Exemptions

- (a) The Administration, if it considers that the sheltered nature and conditions of the voyage are such as to render the application of the full requirements of this Chapter unreasonable or unnecessary, may to that extent exempt from the requirements of this Chapter individual ships or classes of ships which, in the course of their voyage, do not go more than 20 miles from the nearest land.
- (b) In the case of passenger ships which are employed in special trades for the carriage of large numbers of special trade passengers, such as the pilgrim trade, the Administration, if satisfied that it is impracticable to enforce compliance with the requirements of this Chapter, may exempt such ships, when they belong to its country, from those requirements, provided that they comply fully with the provisions of:
 - (i) the Rules annexed to the Special Trade Passenger Ships Agreement, 1971; and
 - (ii) the Rules annexed to the Protocol on Space Requirements for Special Trade Passenger Ships, 1973, when it enters into force.

Regulation 4. Ready Availability of Lifeboats, Liferafts and Buoyant Apparatus

- (a) The general principle governing the provision of lifeboats, liferafts and buoyant apparatus in a ship to which this Chapter applies is that they shall be readily available in case of emergency.

- (b) To be readily available, the lifeboats, liferafts and buoyant apparatus shall comply with the following conditions:
 - (i) they shall be capable of being put into the water safely and rapidly even under unfavourable conditions of trim and of 15 degree of list;
 - (ii) it shall be possible to effect embarkation into the lifeboats and liferafts rapidly and in good order;
 - (iii) the arrangement of each lifeboat, liferaft and article of buoyant apparatus shall be such that it will not interfere with the operation of other boats, liferafts and buoyant apparatus.
- (c) All the life-saving appliances shall be kept in working order and available for immediate use before the ship leaves port and at all times during the voyage.

Regulation 5. Construction of Lifeboats

- (a) All lifeboats shall be properly constructed and shall be of such form and proportions that they shall have ample stability in a seaway, and sufficient freeboard when loaded with their full complement of persons and equipment. All lifeboats shall be capable of maintaining positive stability when open to the sea and loaded with their full complement of persons and equipment.
- (b)
 - (i) All lifeboats shall have rigid sides and internal buoyancy only. The Administration may approve lifeboats with a rigid shelter, provided that it may be readily opened from both inside and outside, and does not impede rapid embarkation and disembarkation or the launching and handling of the lifeboat.
 - (ii) Motor lifeboats may be fitted to the satisfaction of the Administration with a means for preventing the entry of water at the fore end.
 - (iii) All lifeboats shall be not less than 7.3 metres (24 feet) in length except where owing to the size of the ship, or for other reasons, the Administration considers the carriage of such lifeboats unreasonable or impracticable. In no ship shall the lifeboats be less than 4.9 metres (16 feet) in length.
- (c) No lifeboat may be approved the weight of which when fully laden with persons and equipment exceeds 20,300 kilogrammes (20 tons) or which has a carrying capacity calculated in accordance with Regulation 7 of this Chapter of more than 150 persons.
- (d) All lifeboats permitted to carry more than 60 persons but not more than 100 persons shall be either motor lifeboats complying with the requirements of Regulation 9 of this Chapter or be lifeboats fitted with an approved means of mechanical propulsion complying with Regulation 10 of this Chapter. All lifeboats permitted to carry more than 100 persons shall be motor lifeboats complying with the requirements of Regulation 9 of this Chapter.
- (e) All lifeboats shall be of sufficient strength to enable them to be safely lowered into the water when loaded with their full complement of persons and equipment. All lifeboats shall be of such strength that they will not suffer residual deflection if subjected to an overload of 25 per cent.
- (f) All lifeboats shall have a mean sheer at least equal to 4 per cent of their length. The sheer shall be approximately parabolic in form.
- (g) In lifeboats permitted to carry 100 or more persons the volume of the buoyancy shall be increased to the satisfaction of the Administration.

- (h) All lifeboats shall have inherent buoyancy, or shall be fitted with watertight air cases or other equivalent non-corrodible buoyant material which shall not be adversely affected by oil or oil products, sufficient to float the boat and its equipment when the boat is flooded and open to the sea. An additional volume of watertight air cases or other equivalent non-corrodible buoyant material, which shall not be adversely affected by oil or oil products, equal to at least one-tenth of the cubic capacity of the boat shall also be provided. The Administration may permit the watertight air cases to be filled with a non-corrodible buoyant material which shall not be adversely affected by oil or oil products.
- (i) All thwarts and side-seats shall be fitted as low in the lifeboat as practicable.
- (j) The block coefficient of the cubic capacity as determined in accordance with Regulation 6 of this Chapter of all lifeboats, except wooden lifeboats made of planks, shall be not less than 0.64 provided that any such lifeboat may have a block coefficient of less than 0.64 if the Administration is satisfied with the sufficiency of the metacentric height and freeboard when the lifeboat is loaded with its full complement of persons and equipment.

Regulation 6. Cubic Capacity of Lifeboats

- (a) The cubic capacity of a lifeboat shall be determined by Simpson's (Stirling's) Rule or by any other method giving the same degree of accuracy. The capacity of a square-sterned lifeboat shall be calculated as if the lifeboat had a pointed stern.
- (b) For example, the capacity in cubic metres (or cubic feet) of a lifeboat, calculated by the aid of Simpson's Rule, may be considered as given by the following formula:

$$Capacity = \frac{L}{12} (4A + 2B + 4C)$$

L being the length of the lifeboat in metres (or feet) from the inside of the planking or plating at the stem to the corresponding point at the stern post: in the case of a lifeboat with a square stern, the length is measured to the inside of the transom.

A, B, C denote respectively the areas of the cross-sections at the quarter-length forward, amidships, and the quarter-length aft, which correspond to the three points obtained by dividing L into four equal parts. (The areas corresponding to the two ends of the lifeboat are considered negligible.)

The areas A, B, C shall be deemed to be given in square metres (or square feet) by the successive application of the following formula to each of the three cross-sections:

$$Area = \frac{h}{12} (a + 4b + 2c + 4d + e),$$

h being the depth measured in metres (or in feet) inside the planking or plating from the keel to the level of the gunwale, or, in certain cases, to a lower level as determined hereafter.

[Letter symbols] a, b, c, d, e denote the horizontal breadths of the lifeboat measured in metres (or in feet) at the upper and lower points of the depth and at the three points obtained by dividing h into four equal parts (a and e being the breadths at the extreme point, and c at the middle point of h).

- (c) If the sheer of the gunwale, measured at the two points situated at a quarter of the length of the lifeboat from the ends, exceeds 1 per cent of the length of the lifeboat the depth employed in calculating the area of the cross-sections A or C shall be deemed to be the depth amidships plus 1 per cent of the length of the lifeboat.
- (d) If the depth of the lifeboat amidships exceeds 45 per cent of the breadth, the depth employed in calculating the area of the amidship cross-section B shall be deemed to be equal to 45 per cent of the breadth, and the depth employed in calculating the areas of the quarter-length sections A and C is obtained by increasing this last figure by an amount equal to 1 per cent of the length of the lifeboat, provided that in no case shall the depths employed in the calculation exceed the actual depths at these points.
- (e) If the depth of the lifeboat is greater than 1.22 metres (4 feet) the number of persons given by the application of this Rule shall be reduced in proportion to the ratio of 1.22 metres (4 feet) to the actual depth, until the lifeboat has been satisfactorily tested afloat with that number of persons on board, all wearing life-jackets.
- (f) The Administration shall impose, by suitable formulae, a limit for the number of persons allowed in lifeboats with very fine ends and in lifeboats very full in form.
- (g) The Administration may assign to a lifeboat constructed of wooden planks capacity equal to the product of the length, the breadth and the depth multiplied by 0.6 if it is evident that this formula does not give a greater capacity than that obtained by the above method. The dimensions shall then be measured in the following manner:
- Length - From the intersection of the outside of the planking with the stem to the corresponding point at the stern post or, in the case of a square-sterned boat, to the after side of the transom.
 - Breadth - From the outside of the planking at the point where the breadth of the boat is greatest.
 - Depth - Amidships inside the planking from the keel to the level of the gunwale, but the depth used in calculating the cubic capacity may not in any case exceed 45 per cent of the breadth.

In all cases the shipowner has the right to require that the cubic capacity of the lifeboat shall be determined by exact measurement.

- (h) The cubic capacity of a motor lifeboat or a lifeboat fitted with other propelling gear shall be obtained from the gross capacity by deducting a volume equal to that occupied by the motor and its accessories or the gearbox of the other propelling gear, and, when carried, the radiotelegraph installation and searchlight with their accessories.

Regulation 7. Carrying Capacity of Lifeboats

The number of persons which a lifeboat shall be permitted to accommodate shall be equal to the greatest whole number obtained by dividing the capacity in cubic metres by:

- In the case of a lifeboat of 7.3 metres (24 feet) in length or over, 0.283 (or where the capacity is measured in cubic feet 10),
- In the case of lifeboats of 4.9 metres (16 feet) in length, 0.396 (or where the capacity is measured in cubic feet 14); and

- In the case of lifeboats of 4.9 metres (16 feet) in length or over but under 7.3 metres (24 feet), a number between 0.396 and 0.283 (or where the capacity is measured in cubic feet between 14 and 10) to be obtained by interpolation

provided that the number shall in no case exceed the number of adult persons wearing life-jackets which can be seated without in any way interfering with the use of oars or the operation of other propulsion equipment.

Regulation 8. Number of Motor Lifeboats to Be Carried

- (a) In every passenger ship there shall be carried on each side of the ship at least one motor lifeboat complying with the requirements of Regulation 9 of this Chapter. Provided that in passenger ships in which the total number of persons which the ship is certified to carry, together with the crew, does not exceed 30, only one such motor lifeboat shall be required.
- (b) In every cargo ship of 1,600 tons gross tonnage and upwards, except tankers, ships employed as whale factory ships, ships employed as fish processing or canning factory ships, and ships engaged in the carriage of persons in the whaling, fish processing or canning industries, there shall be carried at least one motor lifeboat complying with the requirements of Regulation 9 of this Chapter.
- (c) In every tanker of 1,600 tons gross tonnage and upwards, in every ship employed as a whale factory ship, in every ship employed as a fish processing or canning factory ship and in every ship engaged in the carriage of persons employed in the whaling, fish processing or canning industries, there shall be carried on each side at least one motor lifeboat complying with the requirements of Regulation 9 of this Chapter.

Regulation 9. Specification of Motor Lifeboats

- (a) A motor lifeboat shall comply with the following conditions:
 - (i) It shall be fitted with a compression ignition engine and kept so as to be at all times ready for use; it shall be capable of being readily started in all conditions; sufficient fuel for 24 hours continuous operation at the speed specified in sub-paragraph (iii) of this paragraph shall be provided.
 - (ii) The engine and its accessories shall be suitably enclosed to ensure operation under adverse weather conditions, and the engine casing shall be fire-resisting. Provision shall be made for going astern.
 - (iii) The speed ahead in smooth water when loaded with its full complement of persons and equipment shall be:
 - (1) In the case of motor lifeboats required by Regulation 8 of this Chapter to be carried in passenger ships, tankers, ships employed as whale factory ships, ships employed as fish processing or canning factory ships and ships engaged in the carriage of persons employed in the whaling, fish processing or canning industries, at least six knots.
 - (2) In the case of any other motor lifeboat, at least four knots.
- (b) The volume of the internal buoyancy appliances of a motor lifeboat shall be increased above that required by Regulation 5 of this Chapter by the amount, if any, by which the volume of the internal buoyancy appliances required to support the engine and its accessories, and, if fitted, the searchlight and radiotelegraph installation and their accessories, exceeds the volume of the

internal buoyancy appliances required, at the rate of 0.0283 cubic metres (one cubic foot) per person, to support the additional persons which the lifeboat could accommodate if the motor and its accessories, and, if fitted, the searchlight and radiotelegraph installation and their accessories, were removed.

Regulation 10. Specification of Mechanically Propelled Lifeboats Other Than Motor Lifeboats

A mechanically propelled lifeboat, other than a motor lifeboat, shall comply with the following conditions:

- (a) The propelling gear shall be of an approved type and shall have sufficient power to enable the lifeboat to be readily cleared from the ship's side when launched and be able to hold course under adverse weather conditions. If the gear is manually operated it shall be capable of being worked by persons untrained in its use and shall be capable of being operated when the lifeboat is flooded.
- (b) A device shall be fitted by means of which the helmsman can cause the lifeboat to go astern at any time when the propelling gear is in operation.
- (c) The volume of the internal buoyancy of a mechanically propelled lifeboat, other than a motor lifeboat, shall be increased to compensate for the weight of the propelling gear.

Regulation 11. Equipment of Lifeboats

- (a) The normal equipment of every lifeboat shall consist of:
 - (i) a single banked complement of buoyant oars, two spare buoyant oars, and a buoyant steering oar; one set and a half of thole pins or crutches, attached to the lifeboat by lanyard or chain; a boat hook;
 - (ii) two plus for each plug hole (plugs are not required when proper automatic valves are fitted) attached to the lifeboat by lanyards or chains; a baler, and two buckets of approved material;
 - (iii) a rudder attached to the lifeboat and a tiller;
 - (iv) two hatchets, one at each end of the lifeboat;
 - (v) a lamp, with oil sufficient for 12 hours; two boxes of suitable matches in a watertight container;
 - (vi) a mast or masts, with galvanized wire stays together with sails (coloured orange);
 - (vii) an efficient compass in binnacle, to be luminised or fitted with suitable means of illumination;
 - (viii) a lifeline becketed around the outside of the lifeboat;
 - (ix) a sea-anchor of approved size;
 - (x) two painters of sufficient length. One shall be secured to the forward end of the lifeboat with strop and toggle so that it can be released, and the other shall be firmly secured to the stem of the lifeboat and be ready for use;

- (xi) a vessel containing 4 1/2 litres (1 gallon) of vegetable, fish or animal oil. The vessel shall be so constructed that the oil can be easily distributed on the water, and so arranged that it can be attached to the sea-anchor;
 - (xii) a food ration, determined by the Administration, for each person the lifeboat is certified to carry. These rations shall be kept in airtight receptacles which are to be stowed in a watertight container;
 - (xiii) watertight receptacles containing 3 litres (6 pints) of fresh water for each person the lifeboat is certified to carry, or watertight receptacles containing 2 litres (4 pints) of fresh water for each person together with an approved de-salting apparatus capable of providing 1 litre (2 pints) of drinking water per person; a rustproof dipper with lanyard; a rustproof graduated drinking vessel;
 - (xiv) four parachute signals of approved type capable of giving a bright red light at a high altitude; six hand flares of an approved type giving a bright red light;
 - (xv) two buoyant smoke signals of an approved type (for day-time use) capable of giving off a volume of orange-coloured smoke;
 - (xvi) approved means to enable persons to cling to the boat should it be upturned, in the form of bilge keels or keel rails, together with grab lines secured from gunwale to gunwale under the keel, or other approved arrangements;
 - (xvii) an approved first-aid outfit in a watertight case;
 - (xviii) a waterproof electric torch suitable for signalling in the Morse Code together with one spare set of batteries and one spare bulb in a waterproof container;
 - (xix) a daylight-signalling mirror of an approved type;
 - (xx) a jack-knife fitted with a tin-opener to be kept attached to the boat with a lanyard;
 - (xxi) two light buoyant heaving lines;
 - (xxii) a manual pump of an approved type;
 - (xxiii) a suitable locker for stowage of small items of equipment;
 - (xxiv) one whistle or equivalent sound signal;
 - (xxv) one set of fishing tackle;
 - (xxvi) one approved cover of a highly visible colour capable of protecting the occupants against injury by exposure; and
 - (xxvii) one copy of the illustrated table of life-saving signals referred to in Regulation 16 of Chapter V.
- (b) In the case of ships engaged on voyages of such duration that in the opinion of the Administration the items specified in sub-paragraphs (vi), (xii), (xix), (xx) and (xxv) of paragraph (a) of this Regulation are unnecessary, the Administration may allow them to be dispensed with.

- (c) Notwithstanding the provisions of paragraph (a) of this Regulation, motor lifeboats or other approved mechanically propelled lifeboats need not carry a mast or sails or more than half the complement of oars, but they shall carry two boat hooks.
- (d) All lifeboats shall be fitted with suitable means to enable persons in the water to climb into the lifeboat.
- (e) Every motor lifeboat shall carry portable fire-extinguishing equipment of an approved type capable of discharging froth or other suitable substance for extinguishing oil fires.

Regulation 12. Security of Lifeboat Equipment

All items of lifeboat equipment, with the exception of the boat hook which shall be kept free for fending off purposes, shall be suitably secured within the lifeboat. The lashing shall be carried out in such a manner as to ensure the security of the equipment and so as not to interfere with the lifting hooks or to prevent ready embarkation. All items of lifeboat equipment shall be as small and light in weight as possible and shall be packed in suitable and compact form.

Regulation 13. Portable Radio Apparatus for Survival Craft

- (a) An approved portable radio apparatus for survival craft complying with the requirements set out in Regulation 14 of Chapter IV shall be carried in all ships except those on which there is carried on each side of the ship a motor lifeboat fitted with a radiotelegraph installation complying with the provisions of Regulation 14 of this Chapter and of Regulation 13 of Chapter IV. All this equipment shall be kept together in the chartroom or other suitable place ready to be moved to one or other of the lifeboats in the event of an emergency. However, in tankers of 3,000 tons gross tonnage and upwards in which lifeboats are fitted amidships and aft this equipment shall be kept in a suitable place in the vicinity of those lifeboats which are furthest away from the ship's main transmitter.
- (b) In the case of ships engaged on voyages of such duration that in the opinion of the Administration portable radio apparatus for survival craft is unnecessary, the Administration may allow such equipment to be dispensed with.

Regulation 14. Radio Apparatus and Searchlights in Motor Lifeboats

- (a) (i) Where the total number of persons on board a passenger ship engaged on international voyages which are not short international voyages, a ship employed as a whale factory ship, a ship employed as a fish processing or canning factory ship or a ship engaged in the carriage of persons employed in the whaling, fish processing or canning industries, is more than 199 but less than 1,500, a radiotelegraph apparatus complying with the requirements set out in this Regulation and in Regulation 13 of Chapter IV shall be fitted in at least one of the motor lifeboats required under Regulation 8 of this Chapter to be carried in that ship.
- (ii) Where the total number of persons on board such a ship is 1,500 or more, such a radiotelegraph apparatus shall be fitted in every motor lifeboat required under Regulation 8 of this Chapter to be carried in that ship.
- (b) The radio apparatus shall be installed in a cabin large enough to accommodate both the equipment and the person using it.
- (c) The arrangements shall be such that the efficient operation of the transmitter and receiver shall not be interfered with by the engine while it is running, whether a battery is on charge or not.

- (d) The radio battery shall not be used to supply power to any engine starting motor or ignition system.
- (e) The motor lifeboat engine shall be fitted with a dynamo for recharging the radio battery, and for other services.
- (f) A searchlight shall be fitted in each motor lifeboat required to be carried under paragraph (a) of Regulation 8 of this Chapter in passenger ships and under paragraph (c) of that Regulation in ships employed as whale factory ships, fish processing or canning factory ships and ships engaged in the carriage of persons employed in the whaling, fish processing or canning industries.
- (g) The searchlight shall include a lamp of at least 80 watts, an efficient reflector and a source of power which will give effective illumination of a light-coloured object having a width of about 18 metres (60 feet) at a distance of 180 metres (200 yards) for a total period of six hours and shall be capable of working for at least three hours continuously.

Regulation 15. Requirements for Inflatable Liferafts

- (a) Every inflatable liferaft shall be so constructed that, when fully inflated and floating with the cover uppermost, it shall be stable in a seaway.
- (b) The liferaft shall be so constructed that if it is dropped into the water from a height of 18 metres (60 feet) neither the liferaft nor its equipment will be damaged. If the raft is to be stowed on the ship at a height above the water more than 18 metres (60 feet), it shall be of a type which has been satisfactorily drop-tested from a height at least equal to the height at which it is to be stowed.
- (c) The construction of the liferaft shall include a cover which shall automatically be set in place when the liferaft is inflated. This cover shall be capable of protecting the occupants against injury from exposure, and means shall be provided for collecting rain. The top of the cover shall be fitted with a lamp which derives its luminosity from a sea-activated cell and a similar lamp shall also be fitted inside the liferaft. The cover of the liferaft shall be of a highly visible colour.
- (d) The liferaft shall be fitted with a painter and shall have a line securely becketed round the outside. A lifeline shall also be fitted around the inside of the liferaft.
- (e) The liferaft shall be capable of being readily righted by one person if it inflates in an inverted position.
- (f) The liferaft shall be fitted at each opening with efficient means to enable persons in the water to climb on board.
- (g) The liferaft shall be contained in a valise or other container so constructed as to be capable of withstanding hard wear under conditions met with at sea. The liferaft in its valise or other container shall be inherently buoyant.
- (h) The buoyancy of the liferaft shall be so arranged as to ensure by a division into an even number of separate compartments, half of which shall be capable of supporting out of the water the number of persons which the liferaft is permitted to accommodate, or by some other equally efficient means, that there is a reasonable margin of buoyancy if the raft is damaged or partially fails to inflate.

- (i) The total weight of the liferaft, its valise or other container and its equipment shall not exceed 180 kilogrammes (400 lbs.).
- (j) The number of persons which an inflatable liferaft shall be permitted to accommodate shall be equal to:
 - (i) the greatest whole number obtained by dividing by 96 the volume, measured in cubic decimetres (or by 3.4 the volume, measured in cubic feet) of the main buoyancy tubes (which for this purpose shall include neither the arches nor the thwart or thwarts if fitted) when inflated; or
 - (ii) the greatest whole number obtained by dividing by 3,720 the area measured in square centimetres (or by 4 the area, measured in square feet) of the floor (which for this purpose may include the thwart or thwarts if fitted) of the liferaft when inflated whichever number shall be the less.
- (k) The floor of the liferaft shall be waterproof and shall be capable of being sufficiently insulated against cold.
- (l) The liferaft shall be inflated by a gas which is not injurious to the occupants and the inflation shall take place automatically either on the pulling of a line or by some other equally simple and efficient method. Means shall be provided whereby the topping-up pump or bellows required by Regulation 17 of this Chapter may be used to maintain pressure.
- (m) The liferaft shall be of approved material and construction, and shall be so constructed as to be capable of withstanding exposure for 30 days afloat in all sea conditions.
- (n) No liferaft shall be approved which has a carrying capacity calculated in accordance with paragraph (j) of this Regulation of less than six persons. The maximum number of persons calculated in accordance with that paragraph for which an inflatable liferaft may be approved shall at the discretion of the Administration, but shall in no case exceed 25.
- (o) The liferaft shall be capable of operating throughout a temperature range of 66°C to minus 30°C (150°F to minus 22°F).
- (p) (i) The liferaft shall be so stowed as to be readily available in case of emergency. It shall be stowed in such a manner as to permit it to float free from its stowage, inflate and break free from the vessel in the event of sinking.
 - (ii) If used, lashing shall be fitted with an automatic release system of a hydrostatic or equivalent nature approved by the Administration.
 - (iii) The liferaft required by paragraph (c) of Regulation 35 of this Chapter may be securely fastened.
- (q) The liferaft shall be fitted with arrangements enabling it to be readily towed.

Regulation 16. Requirements for Rigid Liferafts

- (a) Every rigid liferaft shall be so constructed that if it is dropped into the water from its stowed position neither the liferaft nor its equipment will be damaged.

- (b) The deck area of the liferaft shall be situated within that part of the liferaft which affords protection to its occupants. The area of that deck shall be at least 0.3720 square metres (4 square feet) for every person the liferaft is permitted to carry. The nature of the deck shall be such as to prevent so far as practicable the ingress of water and it shall effectively support the occupants out of the water.
- (c) The liferaft shall be fitted with a cover or equivalent arrangement of a highly visible colour, which shall be capable of protecting the occupants against injury from exposure whichever way up the liferaft is floating.
- (d) The equipment of the liferaft shall be so stowed as to be readily available whichever way up the liferaft is floating.
- (e) The total weight of a liferaft and its equipment carried in passenger ships shall not exceed 180 kilogrammes (400 lbs.). Liferafts carried in cargo ships may exceed 180 kilogrammes (400 lbs.) in weight if they are capable of being launched from both sides of the ship or if there are provided means for putting them into the water mechanically.
- (f) The liferaft must at all times be effective and stable when floating either way up.
- (g) The liferaft shall have at least 96 cubic decimetres (3.4 cubic feet) of air cases or equivalent buoyancy for each person it is permitted to carry which must be placed as near as possible to the side of the raft.
- (h) The liferaft shall have a painter attached and a lifeline securely becketed round the outside. A lifeline shall also be fitted around the inside of the raft.
- (i) The liferaft shall be fitted at each opening with efficient means to enable persons in the water to climb on board.
- (j) The liferaft shall be so constructed as not to be affected by oil or oil products.
- (k) A buoyant light of the electric battery type shall be attached to the liferaft by a lanyard.
- (l) The liferaft shall be fitted with arrangements enabling it to be readily towed.
- (m) Liferafts shall be so stowed as to float free in the event of the ship sinking.

Regulation 17. Equipment of Inflatable and Rigid Liferafts

- (a) The normal equipment of every liferaft shall consist of:
 - (i) One buoyant rescue quoit, attached to at least 30 metres (100 feet) of buoyant line.
 - (ii) For liferafts which are permitted to accommodate not more than 12 persons: one knife and one baler; for liferafts which are permitted to accommodate 13 persons or more: two knives and two balers.
 - (iii) Two sponges.
 - (iv) Two sea-anchors, one permanently attached to the liferaft and one spare.
 - (v) Two paddles.

- (vi) One repair outfit capable of repairing punctures in buoyancy compartments.
 - (vii) One topping-up pump or bellows, unless the liferaft complies with Regulation 16 of this Chapter.
 - (viii) Three tin-openers.
 - (ix) One approved first-aid outfit in a waterproof case.
 - (x) One rustproof graduated drinking vessel.
 - (xi) One waterproof electric torch suitable for signalling in the Morse Code, together with one spare set of batteries and one spare bulb in a waterproof container.
 - (xii) One daylight-signalling mirror and one signalling whistle.
 - (xiii) Two parachute distress signals of an approved type, capable of giving a bright red light at a high altitude.
 - (xiv) Six hand flares of an approved type, capable of giving a bright red light.
 - (xv) One set of fishing tackle.
 - (xvi) A food ration, determined by the Administration, for each person the liferaft is permitted to accommodate.
 - (xvii) Watertight receptacles containing 1 1/2 litres (3 pints) of fresh water for each person the liferaft is permitted to accommodate, of which 1/2 litre (1 pint) per person may be replaced by a suitable de-salting apparatus capable of producing an equal amount of fresh water.
 - (xviii) Six anti-seasickness tablets for each person the liferaft is deemed fit to accommodate.
 - (xix) Instructions on how to survive in the liferaft; and
 - (xx) one copy of the illustrated table of life-saving signals referred to in Regulation 16 of Chapter V.
- (b) In the case of passenger ships engaged on short international voyages of such duration that in the opinion of the Administration all the items specified in paragraph (a) of this Regulation are unnecessary, the Administration may allow one or more liferafts, not being less than one-sixth of the number of liferafts carried in any such ship, to be provided with the equipment specified in sub-paragraphs (i) to (vii) inclusive, (xi) and (xix) of paragraph (a) of this Regulation, and with one-half of the equipment specified in sub-paragraphs (xiii) and (xiv) of that paragraph and the remainder of the liferafts carried to be provided with the equipment specified in sub-paragraphs (i) to (vii) inclusive and (xix) of that paragraph.

Regulation 18. Training in the Use of Liferafts

The Administration shall so far as is practicable and reasonable take steps with a view to ensuring that crews of ships in which liferafts are carried are trained in their launching and use.

Regulation 19. Embarkation into Lifeboats and Liferrafts

- (a) Suitable arrangements shall be made for embarkation into the lifeboats, which shall include:
- (i) a ladder at each set of davits to afford access to the lifeboats when waterborne, except that in passenger ships, ships employed as whale factory ships, ships employed as fish processing or canning factory ships and ships engaged in the carriage of persons employed in the whaling, fish processing or canning industries, the Administration may permit such ladders to be replaced by approved devices provided that there shall not be less than one ladder on each side of the ship;
 - (ii) means for illuminating the lifeboats and their launching gear during preparation for and the process of launching, and also for illuminating the water into which the lifeboats are launched until the process of launching is completed;
 - (iii) arrangements for warning the passengers and crew that the ship is about to be abandoned; and
 - (iv) means for preventing any discharge of water into the lifeboats.
- (b) Suitable arrangements shall also be made for embarkation into the liferafts, which shall include:
- (i) sufficient ladders to facilitate embarkation into the liferafts when waterborne except that in passenger ships, ships employed as whale factory ships, ships employed as fish processing or canning factory ships, and ships engaged in the carriage of persons employed in the whaling, fish processing or fish canning industries, the Administration may permit the replacement of some or all of such ladders by approved devices;
 - (ii) where there are carried liferafts for which approved launching devices are provided, means for illuminating those liferafts and launching devices during the preparation for and the process of launching, and also for illuminating the water into which those liferafts are launched until the process of launching is completed;
 - (iii) means for illuminating the stowage position of liferafts for which approved launching devices are not provided;
 - (iv) arrangements for warning the passengers and crew that the ship is about to be abandoned; and
 - (v) means for preventing any discharge of water into the liferafts at fixed launching positions, including those under approved launching devices.

Regulation 20. Marking of Lifeboats, Liferrafts and Buoyant Apparatus

- (a) The dimensions of a lifeboat and the number of persons which it is permitted to carry shall be marked on it in clear permanent characters. The name and port of registry of the ship to which the lifeboat belongs shall be painted on each side of the bow.
- (b) Buoyant apparatus shall be marked with the number of persons in the same manner.
- (c) The number of persons shall be marked in the same manner on inflatable liferafts and also on the valise or container in which the inflatable liferaft is contained. Every inflatable liferaft shall also bear a serial number and the manufacturer's name so that the owner of the liferaft can be ascertained.

- (d) Every rigid liferaft shall be marked with the name and port of registry of the ship in which it is carried, and with the number of persons it is permitted to carry.
- (e) No lifeboat, liferaft or buoyant apparatus shall be marked for a greater number of persons than that obtained in the manner specified in this Chapter.

Regulation 21. Specification of a Lifebuoy

- (a) A lifebuoy shall satisfy the following requirements;
 - (i) it shall be of solid cork or any other equivalent material;
 - (ii) it shall be capable of supporting in fresh water for 24 hours at least 14.5 kilogrammes (32 lbs.) of iron;
 - (iii) it shall not be adversely affected by oil or oil products;
 - (iv) it shall be of a highly visible colour;
 - (v) it shall be marked in block letters with the name and port of registry of the ship in which it is carried.
- (b) Lifebuoys filled with rushes, cork shavings or granulated cork, or any other loose granulated material, or whose buoyancy depends upon air compartments which require to be inflated, are prohibited.
- (c) Lifebuoys made of plastic or other synthetic compounds shall be capable of retaining their buoyant properties and durability in contact with sea water or oil products, or under variations of temperature or climatic changes prevailing in open sea voyages.
- (d) Lifebuoys shall be fitted with beackets securely seized. At least one lifebuoy on each side of the ship shall be fitted with a buoyant lifeline of at least 27.5 metres (15 fathoms) in length.
- (e) In passenger ships not less than one-half of the total number of lifebuoys, and in no case less than six, and in cargo ships at least one-half of the total number of lifebuoys, shall be provided with efficient self-igniting lights.
- (f) The self-igniting lights required by paragraph (e) of this Regulation shall be such that they cannot be extinguished by water. They shall be capable of burning for not less than 45 minutes and shall have a luminous intensity of not less than 2 candelas in all directions of the upper hemisphere. The lights shall be kept near the lifebuoys to which they belong, with the necessary means of attachment. Self-igniting lights used in tankers shall be of an approved electric battery type.
- (g) All lifebuoys shall be so placed as to be readily accessible to the persons on board, and at least two of the lifebuoys provided with self-igniting lights in accordance with paragraph (e) of this Regulation shall also be provided with an efficient self-activating smoke signal capable of producing smoke of a highly visible colour for at least 15 minutes, and shall be capable of quick release from the navigating bridge.
- (h) Lifebuoys shall always be capable of being rapidly cast loose and shall not be permanently secured in any way.

Regulation 22. Life-Jackets

- (a) Ships shall carry for every person on board a life-jacket of an approved type and, in addition, unless these life-jackets can be adapted for use by children, a sufficient number of life-jackets suitable for children. Each life-jacket shall be suitably marked showing that it has been approved by the Administration.
- (b) In addition to the life-jackets required by paragraph (a) of this Regulation there shall be carried on passenger ships life-jackets for 5 per cent of the total number of persons on board. These life-jackets shall be stowed in a conspicuous place on deck.
- (c) An approved life-jacket shall comply with the following requirements:
 - (i) it shall be constructed with proper workmanship and materials;
 - (ii) it shall be so constructed as to eliminate so far as possible all risk of its being put on incorrectly, except that it shall be capable of being worn inside out;
 - (iii) it shall be capable of lifting the face of an exhausted or unconscious person out of the water and holding it above the water with the body inclined backwards from its vertical position;
 - (iv) it shall be capable of turning the body in the water from any position to a safe floating position with the body inclined backwards from its vertical position;
 - (v) it shall not be adversely affected by oil or oil products;
 - (vi) it shall be of a highly visible colour;
 - (vii) it shall be fitted with an approved whistle, firmly secured by a cord;
 - (viii) the buoyancy of the life-jacket required to provide the foregoing performance shall not be reduced by more than 5 per cent after 24 hours' submergence in fresh water.
- (d) A life-jacket, the buoyancy of which depends on inflation, may be permitted for use by the crews of all ships except passenger ships and tankers provided that:
 - (i) it has two separate inflatable compartments;
 - (ii) it is capable of being inflated both mechanically and by mouth; and
 - (iii) it complies with the requirements of paragraph (c) of this Regulation with either compartment inflated separately.
- (e) Life-jackets shall be so placed as to be readily accessible and their position shall be plainly indicated.

Regulation 23. Line-Throwing Appliances

- (a) Ships shall carry a line-throwing appliance of an approved type.
- (b) The appliance shall be capable of carrying a line not less than 230 metres (250 yards) with reasonable accuracy, and shall include not less than four projectiles and four lines.

Regulation 24. Ships' Distress Signals

Ships shall be provided, to the satisfaction of the Administration, with means of making effective distress signals by day and by night, including at least twelve parachute signals capable of giving a bright red light at a high altitude.

Regulation 25. Muster List and Emergency Procedure

- (i) Special duties to be undertaken in the event of an emergency shall be allotted to each member of the crew.
- (ii) The muster list shall show all the special duties and shall indicate, in particular, the station to which each member must go, and the duties that he has to perform.
- (iii) The muster list for each passenger ship shall be in a form approved by the Administration.
- (iv) Before the vessel sails, the muster list shall be completed. Copies shall be posted in several parts of the ship, and in particular in the crew's quarters.
- (v) The muster list shall show the duties assigned to the different members of the crew in connexion with:
 - (i) the closing of the watertight doors, valves and closing mechanisms of scuppers, ash-shoots and fire doors;
 - (ii) the equipping of the lifeboats (including the portable radio apparatus for survival craft) and the other life-saving appliances;
 - (iii) the launching of the lifeboat;
 - (iv) the general preparation of the other life-saving appliances;
 - (v) the muster of the passengers; and
 - (vi) the extinction of fire, having regard to the ship's fire control plans.
- (vi) The muster list shall show the several duties assigned to the members of the stewards' department in relation to the passengers in case of emergency. These duties shall include:
 - (i) warning the passengers;
 - (ii) seeing that they are suitably clad and have put on their life-jackets in a proper manner;
 - (iii) assembling the passengers at muster stations;
 - (iv) keeping order in the passages and on the stairways, and, generally, controlling the movements of the passengers; and
 - (v) ensuring that a supply of blankets is taken to the lifeboats.
- (vii) The duties shown by the muster list in relation to the extinction of fire pursuant to sub-paragraph (e)(vi) of this Regulation shall include particulars of:
 - (i) the manning of the fire parties assigned to deal with fires;

- (ii) the special duties assigned in respect of the operation of fire-fighting equipment and installations.

- (viii) The muster list shall specify definite signals for calling all the crew to their boat, liferaft and fire stations, and shall give full particulars of these signals. These signals shall be made on the whistle or siren and, except on passenger ships on short international voyages and on cargo ships of less than 45.7 metres (150 feet) in length, they shall be supplemented by other signals which shall be electrically operated. All these signals shall be operable from the bridge.

Regulation 26. Practice Musters and Drills

- (a) (i) In passenger ships, musters of the crew for boat drill and fire drill shall take place weekly when practicable and there shall be such a muster when a passenger ship leaves the final port of departure on an international voyage which is not a short international voyage.

 - (ii) In cargo ships, a muster of the crew for boat drill and fire drill shall take place at intervals of not more than one month, provided that a muster of the crew for boat drill and fire drill shall take place within 24 hours of leaving a port if more than 25 per cent of the crew have been replaced at that port.

 - (iii) On the occasion of the monthly muster in cargo ships the boat's equipment shall be examined to ensure that it is complete.

 - (iv) The date upon which musters are held, and details of any training and drills in fire fighting which are carried out on board shall be recorded in such log book as may be prescribed by the Administration. If in any week (for passenger ships) or month (for cargo ships) no muster or a part muster only is held, an entry shall be made stating the circumstances and extent of the muster held. A report of the examination of the boat's equipment on cargo ships shall be entered in the log book, which shall also record the occasions on which the lifeboats are swung out and lowered in compliance with paragraph (c) of this Regulation.
- (b) In passenger ships, except those engaged on short international voyages, a muster of the passengers shall be held within 24 hours after leaving port.

 - (c) Different groups of lifeboats shall be used in turn at successive boat drills and every lifeboat shall be swung out and, if practicable and reasonable, lowered at least once every four months. The musters and inspections shall be so arranged that the crew thoroughly understand and are practised in the duties they have to perform, including instructions in the handling and operation of liferafts where these are carried.

 - (d) The emergency signal for summoning passengers to muster stations shall be a succession of seven or more short blasts followed by one long blast on the whistle or siren. This shall be supplemented in passenger ships, except those engaged on short international voyages, by other signals, which shall be electrically operated, throughout the ship operable from the bridge. The meaning of all signals affecting passengers, with precise instructions on what they are to do in an emergency, shall be clearly stated in appropriate languages on cards posted in their cabins and in conspicuous places in other passenger quarters.

PART B
PASSENGER SHIPS ONLY

Regulation 27. Lifeboats, Liferafts and Buoyant Apparatus

- (a) Passenger ships shall carry two boats attached to davits - one on each side of the ship - for use in an emergency. These boats shall be of an approved type and shall be not more than 8.5 metres (28 feet) in length. They may be counted for the purposes of paragraphs (b) and (c) of this Regulation, provided that they comply fully with the requirements for lifeboats of this Chapter, and for the purposes of Regulation 8 provided that in addition they comply fully with the requirements of Regulation 9 and where appropriate Regulation 14 of this Chapter. They shall be kept ready for immediate use while the ship is at sea. In ships in which the requirements of paragraph (h) of Regulation 29 are met by means of appliances fitted to the sides of the lifeboats, such appliances shall not be required to be fitted to the two boats provided to meet the requirements of this Regulation.
- (b) Passenger ships engaged on international voyages which are not short international voyages shall carry:
- (i) Lifeboats on each side of such aggregate capacity as will accommodate half the total number of persons on board; provided that the Administration may permit the substitution of lifeboats by liferafts of the same total capacity so however that there shall never be less than sufficient lifeboats on each side of the ship to accommodate 371/2 per cent of all on board.
- (ii) Liferafts of sufficient aggregate capacity to accommodate 25 per cent of the total number of persons on board, together with buoyant apparatus for 3 per cent of that number. Provided that ships which have a factor of subdivision of 0.33 or less shall be permitted to carry, in lieu of liferafts for 25 per cent of all on board and buoyant apparatus for 3 per cent of all on board, buoyant apparatus for 25 per cent of that number.
- (c) (i) A passenger ship engaged on short international voyages shall be provided with sets of davits in accordance with its length as specified in Column A of the Table in Regulation 28 of this Chapter. Each set of davits shall have a lifeboat attached to it and these lifeboats shall provide at least the minimum capacity required by Column C of the Table or the capacity required to provide accommodation for all on board if this is less.

Provided that when in the opinion of the Administration it is impracticable or unreasonable to place on a ship engaged on short international voyages the number of sets of davits required by Column A of the Table in Regulation 28, the Administration may authorize, under exceptional conditions, a smaller number of davits, except that this number shall never be less than the minimum number fixed by Column B of the Table, and that the total capacity of the lifeboats on the ship will be at least equal to the minimum capacity required by Column C or the capacity required to provide for all persons on board if this is less.

- (ii) If the lifeboats so provided are not sufficient to accommodate all on board, additional lifeboats under davits or liferafts shall be provided so that the accommodation provided in the lifeboats and the liferafts in the ship shall be sufficient for all on board.
- (iii) Notwithstanding the provisions of sub-paragraph (ii) of this paragraph in any ship engaged on short international voyages the number of persons carried shall not exceed the total capacity of the lifeboats provided in accordance with sub-paragraphs (i) and (ii) of this paragraph unless the Administration considers that this is necessitated by the volume of

traffic and then only if the ship complies with the provisions of paragraph (d) of Regulation I of Chapter II-1.

- (iv) Where under the provisions of sub-paragraph (iii) of this paragraph the Administration has permitted the carriage of persons in excess of the lifeboat capacity and is satisfied that it is impracticable in that ship to stow the liferafts carried in accordance with sub-paragraph (ii) of this paragraph it may permit a reduction in the number of lifeboats.

Provided that:

- (1) the number of lifeboats shall, in the case of ships of 58 metres (190 feet) in length and over, never be less than four, two of which shall be carried on each side of the ship, and in the case of ships of less than 58 metres (190 feet) in length, shall never be less than two, one of which shall be carried on each side of the ship; and
- (2) the number of lifeboats and liferafts shall always be sufficient to accommodate the total number of persons on board.
- (v) Every passenger ship engaged on short international voyages shall carry in addition to the lifeboats and liferafts required by the provisions of this paragraph, liferafts sufficient to accommodate 10 per cent of the total number of persons for whom there is accommodation in the lifeboats carried in that ship.
- (vi) Every passenger ship engaged on short international voyages shall also carry buoyant apparatus for at least 5 per cent of the total number of persons on board.
- (vii) The Administration may permit individual ships or classes of ships with short international voyage certificates to proceed on voyages in excess of 600 miles but not exceeding 1,200 miles if such ships comply with the provisions of paragraph (d) of Regulation 1 of Chapter II-1, if they carry lifeboats which provide for 75 per cent of the persons on board and otherwise comply with the provisions of this paragraph.

Regulation 28. Table Relating to Davits and Lifeboat Capacity for Ships on Short International Voyages

The following table fixes according to the length of the ship:

- (A) the minimum number of sets of davits to be provided on a ship engaged on short international voyages to each of which must be attached a lifeboat in accordance with Regulation 27 of this Chapter;
- (B) the smaller number of sets of davits which may be authorized exceptionally on a ship engaged on short international voyages under Regulation 27 of this Chapter; and
- (C) the minimum lifeboat capacity required for a ship engaged on short international voyages.

Registered length of ship		(A) Minimum number of sets of davits	(B) Smaller number of sets of davits authorized exceptionally	(C) Minimum capacity of lifeboats	
Metres	Feet			Cubic metres	Cubic feet
31 and under 37	100 and under 120	2	2	11	400
37 and under 43	120 and under 140	2	2	18	650
43 and under 49	140 and under 160	2	2	26	900
49 and under 53	160 and under 175	3	3	33	1,150
53 and under 58	175 and under 190	3	3	38	1,350
58 and under 63	190 and under 205	4	4	44	1,550
63 and under 67	205 and under 220	4	4	50	1,750
67 and under 70	220 and under 230	5	4	52	1,850
70 and under 75	230 and under 245	5	4	61	2,150
75 and under 78	245 and under 255	6	5	68	2,400
78 and under 82	255 and under 270	6	5	76	2,700
82 and under 87	270 and under 285	7	5	85	3,000
87 and under 91	285 and under 300	7	5	94	3,300
91 and under 96	300 and under 300	8	6	102	3,600
96 and under 101	315 and under 335	8	6	110	3,900
101 and under 107	330 and under 350	9	7	122	4,300
107 and under 113	350 and under 370	9	7	135	4,750
113 and under 119	370 and under 390	10	7	146	5,150
119 and under 125	390 and under 410	10	7	157	5,550
125 and under 133	410 and under 435	12	9	171	6,050
133 and under 140	435 and under 460	12	9	185	6,550
140 and under 149	460 and under 490	14	10	202	7,150
149 and under 159	490 and under 520	14	10	221	7,800
159 and under 168	520 and under 550	16	12	238	8,400

Note on (C): Where the length of the ship is under 31 metres (100 feet) or over 168 metres (550 feet) the minimum number of sets of davits and the cubic capacity of the lifeboats shall be prescribed by the Administration.

Regulation 29. Stowage and Handling of Lifeboats, Liferafts and Buoyant Apparatus

- (a) Lifeboats and liferafts shall be stowed to the satisfaction of the Administration in such a way that:
- (i) they can all be launched in the shortest possible time and in not more than 30 minutes;

- (ii) they will not impede in any way the prompt handling of any of the other lifeboats, liferafts or buoyant apparatus or the marshalling of the persons on board at the launching stations, or their embarkation;
 - (iii) the lifeboats, and the liferafts for which approved launching devices are required to be carried, shall be capable of being put into the water loaded with their full complement of persons and equipment even in unfavourable conditions of trim and of 15 degrees of list either way; and
 - (iv) the liferafts for which approved launching devices are not required to be carried, and the buoyant apparatus, shall be capable of being put into the water even in unfavourable conditions of trim and of 15 degrees of list either way.
- (b) Every lifeboat shall be attached to a separate set of davits.
- (c) Lifeboats may only be stowed on more than one deck if proper measures are taken to prevent lifeboats on a lower deck being fouled by those stowed on a deck above.
- (d) Lifeboats, and liferafts for which approved launching devices are required to be carried, shall not be placed in the bow of the ship. They shall be stowed in such positions as to ensure safe launching having particular regard to clearance from the propeller and steeply overhanging portions of the hull aft.
- (e) Davits shall be of approved design and shall be suitably placed to the satisfaction of the Administration. They shall be so disposed on one or more decks that the lifeboats placed under them can be safely lowered without interference from the operation of any other davits.
- (f) Davits shall be as follows:
 - (i) luffing or gravity type for operating lifeboats weighing not more than 2,300 kilogrammes (2¼ tons) in their turning out condition;
 - (ii) gravity type for operating lifeboats weighing more than 2,300 kilogrammes (2¼ tons) in their turning out condition.
- (g) Davits, falls, blocks and all other gear shall be of such strength that the lifeboats can be turned out manned by a launching crew and then safely lowered with the full complement of persons and equipment, with the ship listed to 15 degrees either way and with a 10 degrees trim.
- (h) Skates or other suitable means shall be provided to facilitate launching the lifeboats against a list of 15 degrees.
- (i) Means shall be provided for bringing the lifeboats against the ship's side and there holding them so that persons may be safely embarked.
- (j) Lifeboats, together with the emergency boats required by Regulation 27 of this Chapter, shall be served by wire rope falls, together with winches of an approved type which, in the case of the emergency boats, shall be capable of quick recovery of those boats. Exceptionally, the Administration may allow manila rope falls or falls of another approved material with or without winches (except that the emergency boats shall be required to be served by winches which are capable of quick recovery of those boats) where they are satisfied that manila rope falls or falls of another approved material are adequate.
- (k) At least two lifelines shall be fitted to the davit span, and the falls and lifelines shall be long enough to reach the water with the ship at its lightest seagoing draught and listed to 15 degrees either way. Lower fall blocks shall be fitted with a suitable ring or long link for attaching to the sling hooks unless an approved type of disengaging gear is fitted.

- (l) Where mechanically-powered appliances are fitted for the recovery of the lifeboats, efficient hand gear shall also be provided. Where davits are recovered by action of the falls by power, safety devices shall be fitted which will automatically cut off the power before the davits come against the stops in order to avoid overstressing the wire rope falls or davits.
- (m) Lifeboats attached to davits shall have the falls ready for service and arrangements shall be made for speedily, but not necessarily simultaneously, detaching the lifeboats from the falls. The point of attachment of the lifeboats to the falls shall be at such height above the gunwale as to ensure stability when lowering the lifeboats.
- (n) (i) In passenger ships engaged on international voyages which are not short international voyages in which there are carried lifeboats and liferafts in accordance with sub-paragraph (b)(i) of Regulation 27 of this Chapter, there shall be provided approved launching devices sufficient in number in the opinion of the Administration to enable that number of liferafts which, together with the lifeboats, is required in accordance with that sub-paragraph to provide accommodation for all on board, to be put into the water loaded with the number of persons they are permitted to accommodate, in not more than thirty minutes in calm conditions. Approved launching devices so provided shall, so far as practicable, be distributed equally on each side of the ship and there shall never be less than one such device on each side. No such devices need, however, be provided for the additional liferafts required to be carried by sub-paragraph (b)(ii) of Regulation 27 of this Chapter for 25 per cent of all on board, but every liferaft carried in accordance with that sub-paragraph shall, where an approved launching device is provided in the ship, be of a type which is capable of being launched from such a device.
- (ii) In passenger ships engaged on short international voyages, the number of approved launching devices to be provided shall be at the discretion of the Administration. The number of liferafts allocated to each such device carried shall not be more than the number which, in the opinion of the Administration, can be put into the water fully loaded with the number of persons they are permitted to carry by that device in not more than 30 minutes in calm conditions.

Regulation 30. Lighting for Decks, Lifeboats, Liferafts, etc.

- (a) Provision shall be made for an electric or equivalent system of lighting sufficient for all the requirements of safety in the different parts of a passenger ship, and particularly for decks on which the lifeboats and liferafts are stowed. The self-contained emergency source of electrical power required by Regulation 25 of Chapter II-1 shall be capable of supplying where necessary this lighting system and also the lighting required by sub-paragraphs (a)(ii), (b)(ii) and (b)(iii) of Regulation 19 of this Chapter.
- (b) The exit from every main compartment occupied by passengers or crew shall be continuously lighted by an emergency lamp. The power for these emergency lamps shall be so arranged that they will be supplied from the emergency source of power referred to in paragraph (a) of this Regulation in the event of failure of the main generating plant.

Regulation 31. Manning of Lifeboats and Liferafts

- (a) A deck officer or certified lifeboatman shall be placed in charge of each lifeboat and a second-in-command shall also be nominated. The person in charge shall have a list of the lifeboat's crew, and shall see that the men placed under his orders are acquainted with their several duties.
- (b) A man capable of working the motor shall be assigned to each motor lifeboat.
- (c) A man capable of working the radio and searchlight installations shall be assigned to each lifeboat carrying this equipment.

- (d) A man practised in the handling and operation of liferafts shall be assigned to each liferaft carried, except where in ships engaged on short international voyages the Administration is satisfied that this is not practicable.

Regulation 32. Certificated Lifeboatmen

- (a) In passenger ships there shall be, for every lifeboat carried in order to comply with this Chapter, a number of lifeboatmen at least equal to that specified in the following table:

<i>Prescribed complement of lifeboat</i>	<i>The minimum number of certificated lifeboatmen shall be</i>
<i>Less than 41 persons</i>	2
<i>From 41 to 61 persons</i>	3
<i>From 62 to 85 persons</i>	4
<i>Above 85 persons</i>	5

- (b) The allocation of the certificated lifeboatmen to each lifeboat remains within the discretion of the master.
- (c) Certificates of efficiency shall be issued under the authority of the Administration. In order to obtain such a certificate an applicant shall prove that he has been trained in all the operations connected with launching lifeboats and other life-saving appliances and in the use of oars and propelling gear; that he is acquainted with the practical handling of lifeboats and of other life-saving equipment, and further, that he is capable of understanding and answering the orders relative to all kinds of life-saving appliances.

Regulation 33. Buoyant Apparatus

- (a) No type of buoyant apparatus shall be approved unless it satisfies the following conditions:
- (i) It shall be of such size and strength that it can be thrown from the place where it is stowed into the water without being damaged.
 - (ii) It shall not exceed 180 kilogrammes (400 lbs.) in weight unless suitable means to the satisfaction of the Administration are provided to enable it to be launched without lifting by hand.
 - (iii) It shall be of approved material and construction.
 - (iv) It shall be effective and stable when floating either way up.
 - (v) The air cases or equivalent buoyancy shall be placed as near as possible to the sides of the apparatus, and such buoyancy shall not be dependent upon inflation.
 - (vi) It shall be fitted with a painter and have a line securely becketed round the outside.
- (b) The number of persons for which buoyant apparatus is certified shall be the number:
- (i) ascertained by dividing the number of kilogrammes of iron which it is capable of supporting in fresh water by 14.5 (or the number of pounds divided by 32), or
 - (ii) equal to the number of millimetres in the perimeter divided by 305 (or the number of feet in the perimeter), whichever is the less.

Regulation 34. Number of Lifebuoys to Be Provided

The minimum number of lifebuoys with which passenger ships are provided shall be fixed by the following table:

<i>Length of ship</i>		<i>Minimum number of buoys</i>
<i>In metres</i>	<i>In feet</i>	
Under 61	Under 200	8
61 and under 122	200 and under 400	12
122 and under 183	400 and under 600	18
183 and under 244	600 and under 800	24
244 and over	800 and over	30

**PART C
CARGO SHIPS ONLY**

Regulation 35. Number and Capacity of Lifeboats and Liferrafts

- (a) (i) Every cargo ship, except ships employed as whale factory ships, fish processing or canning factory ships, and ships engaged in the carriage of persons employed in the whaling, fish processing or canning industries, shall carry lifeboats on each side of the ship of such aggregate capacity as will accommodate all persons on board, and in addition shall carry liferafts sufficient to accommodate half that number.

Provided that, in the case of such cargo ships engaged on international voyages between near neighbouring countries, the Administration, if it is satisfied that the conditions of the voyage are such as to render the compulsory carriage of liferafts unreasonable or unnecessary, may to that extent exempt individual ships or classes of ships from this requirement.

- (ii) (1) Subject to the provisions of sub-paragraph (ii)(2) of this paragraph, every tanker of 3,000 tons gross tonnage and upwards shall carry not less than four lifeboats, two of which shall be carried aft and two amidships, except that in tankers which have no amidships superstructure all lifeboats shall be carried aft.
- (2) A tanker of 3,000 tons gross tonnage and upwards which has no amidships superstructure may be permitted by the Administration to carry two lifeboats only, provided that:
- (aa) one lifeboat is carried aft on each side of the ship;
 - (bb) each such lifeboat shall not exceed 8.5 metres (28 feet) in length;
 - (cc) each such lifeboat shall be stowed as far forward as practicable, but at least so far forward that the after end of the lifeboat is one-and-a-half times the length of the lifeboat forward of the propeller; and
 - (dd) each such lifeboat shall be stowed as near sea level as is safe and practicable.
- (b) (i) Every ship employed as a whale factory ship, every ship employed as a fish processing or canning factory ship and every ship engaged in the carriage of persons employed in the whaling, fish processing or canning industries shall carry:

- (1) Lifeboats on each side of such aggregate capacity as will accommodate half the total number of persons on board; provided that the Administration may permit the substitution of lifeboats by liferafts of the same total capacity so however that there shall never be less than sufficient lifeboats on each side of the ship to accommodate 37½ per cent of all on board.
- (2) Liferafts of sufficient aggregate capacity to accommodate half the total number of persons on board; provided that, if in ships employed as fish processing or canning factory ships, it is impracticable to carry lifeboats which comply fully with the requirements of this Chapter, the Administration may permit instead the carriage of other boats, which shall however provide not less than the accommodation required by this Regulation and shall have at least the buoyancy and equipment required by this Chapter for lifeboats.
- (iii) Every ship employed as a whale factory ship, every ship employed as a fish processing or canning factory ship and every ship engaged in the carriage of persons employed in the whaling, fish processing or canning industries shall carry two boats - one on each side - for use in an emergency. These boats shall be of an approved type and shall be not more than 8.5 metres (28 feet) in length. They may be counted for the purposes of this paragraph provided that they comply fully with the requirements for lifeboats of this Chapter and for the purposes of Regulation 8 provided that in addition they comply with the requirements of Regulation 9, and, where appropriate, Regulation 14 of this Chapter. They shall be kept ready for immediate use while the ship is at sea. In ships in which the requirements of paragraph (g) of Regulation 36 of this Chapter are met by means of appliances fitted to the sides of the lifeboats, such appliances shall not be required to be fitted to the two boats provided to meet the requirements of this Regulation.
- (c) Every cargo ship with no amidships superstructure having a registered length of 150 metres (492 feet) and upwards shall carry, in addition to the liferafts required under sub-paragraph (a)(i) of this Regulation, a liferaft capable of accommodating at least six persons which shall be stowed as far forward as is reasonable and practicable.

Regulation 36. Davits and Launching Arrangements

- (a) In cargo ships lifeboats and liferafts shall be stowed to the satisfaction of the Administration.
- (b) Every lifeboat shall be attached to a separate set of davits.
- (c) Lifeboats and liferafts for which approved launching devices are required to be carried shall preferably be positioned as close to accommodation and service spaces as possible. They shall be stowed in such positions as to ensure safe launching, having particular regard to clearance from the propeller and steeply overhanging portions of the hull, with the object of ensuring so far as practicable that they can be launched down the straight side of the ship. If positioned forward they shall be stowed abaft the collision bulkhead in a sheltered position and in this respect the Administration shall give special consideration to the strength of the davits.
- (d) Davits shall be of approved design and shall be suitably placed to the satisfaction of the Administration.

- (e) In tankers of 1,600 tons gross tonnage and upwards, ships employed as whale factory ships, ships employed as fish processing or canning factory ships and ships engaged in the carriage of persons employed in the whaling, fish processing or canning industries, all davits shall be of the gravity type. In other ships, davits shall be as follows:
 - (i) luffing or gravity type for operating lifeboats weighing not more than 2,300 kilogrammes (2¼ tons) in their turning out condition;
 - (ii) gravity type for operating lifeboats weighing more than 2,300 kilogrammes (2¼ tons) in their turning out condition.
- (f) Davits, falls, blocks and all other gear shall be of such strength that the lifeboats can be turned out manned by a launching crew and then safely lowered with the full complement of persons and equipment, with the ship listed to 15 degrees either way, and with a 10 degrees trim.
- (g) Skates or other suitable means shall be provided to facilitate launching the lifeboats against a list of 15 degrees.
- (h) Means shall be provided for bringing the lifeboats against the ship's side and there holding them so that persons may be safely embarked.
- (i) Lifeboats, together with the emergency boats required by sub-paragraph (b)(ii) of Regulation 35 of this Chapter, shall be served by wire rope falls, together with winches of an approved type which, in the case of the emergency boats, shall be capable of quick recovery of those boats. Exceptionally, the Administration may allow manila rope falls or falls of another approved material with or without winches (except that the emergency boats shall be required to be served by winches which are capable of quick recovery of those boats) where they are satisfied that manila rope falls or falls of another approved material are adequate.
- (j) At least two lifelines shall be fitted to the davit spans, and the falls and lifelines shall be long enough to reach the water with the ship at its lightest sea-going draught and listed to 15 degrees either way. Lower fall blocks shall be fitted with a suitable ring or long link for attaching to the sling hooks unless an approved type of disengaging gear is fitted.
- (k) Where mechanically powered appliances are fitted for the recovery of the lifeboats, efficient hand gear shall also be provided. Where davits are recovered by action of the falls by power, safety devices shall be fitted which will automatically cut off the power before the davits come against the stops in order to avoid overstressing the wire rope falls or davits.
- (l) Lifeboats shall have the falls ready for service, and arrangements shall be made for speedily, but not necessarily simultaneously, detaching the lifeboats from the falls. The point of attachment of the lifeboats to the falls shall be at such height above the gunwale as to ensure stability when lowering the lifeboats.
- (m) In ships employed as whale factory ships, ships employed as fish processing or canning factory ships and ships engaged in the carriage of persons employed in the whaling, fish processing or canning industries, in which there are carried lifeboats and liferafts in accordance with sub-paragraph (b)(i)(2) of Regulation 35 no approved launching devices need be provided for the liferafts, but there shall be provided such devices sufficient in number, in the opinion of the Administration, to enable the liferafts carried in accordance with sub-paragraph (b)(i)(1) of that Regulation to be put into the water loaded with the number of persons they are permitted to accommodate, in not more than 30 minutes in calm conditions. Approved launching devices so provided shall, so far as practicable, be distributed equally on each side of the ship. Every liferaft carried on ships in which an approved launching device is required to be provided shall be of a type which is capable of being launched by such a device.

Regulation 37. Number of Lifebuoys to Be Provided

At least eight lifebuoys of a type which satisfies the requirements of Regulation 21 of this Chapter shall be carried.

Regulation 38. Emergency Lighting

The lighting required by sub-paragraphs (a)(ii), (b)(ii) and (b)(iii) of Regulation 19 of this Chapter shall be capable of being supplied for at least three hours by the emergency source of power required by Regulation 26 of Chapter II-1. In cargo ships of 1,600 tons gross tonnage and upwards the Administration shall ensure that the lighting of the alleyways, stairways and exits is such that the access of all persons on board to the launching stations and stowage positions of lifeboats and liferafts is not impeded.

CHAPTER IV RADIOTELEGRAPHY AND RADIOTELEPHONY

PART A APPLICATION AND DEFINITIONS

Regulation 1. Application

- (a) Unless expressly provided otherwise, this Chapter applies to all ships to which the present Regulations apply.
- (b) This Chapter does not apply to ships to which present Regulations would otherwise apply while such ships are being navigated within the Great Lakes of North America and their connecting and tributary waters as far east as the lower exit of the St. Lambert Lock at Montreal in the Province of Quebec, Canada.²³
- (c) No provision in this Chapter shall prevent the use by a ship or survival craft in distress of any means at its disposal to attract attention, make known its position and obtain help.

Regulation 2. Terms and Definitions

For the purpose of this Chapter the following terms shall have the meanings defined below. All other terms which are used in this Chapter and which are also defined in the Radio Regulations shall have the same meanings as defined in those Regulations:

- (i) "Radio Regulations" means the Radio Regulations annexed to, or regarded as being annexed to, the most recent International Telecommunication Convention which may be in force at any time.
- (ii) "Radiotelegraph auto alarm" means an automatic alarm receiving apparatus which responds to the radiotelegraph alarm signal and has been approved.
- (iii) "Radiotelephone auto alarm" means an automatic alarm receiving apparatus which responds to the radiotelephone alarm signal and has been approved.
- (iv) "Radiotelephone station", "Radiotelephone installation" and "Watches - radiotelephone" shall be considered as relating to the medium frequency band, unless expressly provided otherwise.
- (v) "Radio Officer" means a person holding at least a first or second class radiotelegraph operator's certificate, or a radio communication operator's general certificate for the maritime mobile service, complying with the provisions of the Radio Regulations, who is employed in the radiotelegraph station of a ship which is provided with such a station in compliance with the provisions of Regulation 3 or Regulation 4 of this Chapter.
- (vi) "Radiotelephone operator" means a person holding an appropriate certificate complying with the provisions of the Radio Regulations.
- (vii) "Existing installation" means:
 - (i) an installation wholly installed on board a ship before the date on which the present Convention enters into force irrespective of the date on which acceptance by the respective Administration takes effect; and
 - (ii) an installation part of which was installed on board a ship before the date of entry into force of the present Convention and the rest of which consists either of parts installed in replacement of identical parts, or parts which comply with the requirements of this Chapter.

²³ Such ships are subject to special requirements relative to radio for safety purposes, as contained in the relevant agreement between Canada and the United States of America.

(viii) "New installation" means any installation which is not an existing installation.

Regulation 3. Radiotelegraph Station

Passenger ships irrespective of size and cargo ships of 1,600 tons gross tonnage and upwards, unless exempted under Regulation 5 of this Chapter, shall be fitted with a radiotelegraph station complying with the provisions of Regulations 9 and 10 of this Chapter.

Regulation 4. Radiotelephone Station

Cargo ships of 300 tons gross tonnage and upwards but less than 1,600 tons gross tonnage, unless fitted with a radiotelegraph station complying with the provisions of Regulations 9 and 10 of this Chapter shall, provided they are not exempted under Regulation 5 of this Chapter, be fitted with a radiotelephone station complying with the provisions of Regulations 15 and 16 of this Chapter.

Regulation 5. Exemptions from Regulations 3 and 4

- (a) The Contracting Governments consider it highly desirable not to deviate from the application of Regulations 3 and 4 of this Chapter; nevertheless the Administration may grant to individual passenger or cargo ships exemptions of a partial and/or conditional nature, or complete exemption from the requirements of Regulation 3 or Regulation 4 of this Chapter.
- (b) The exemptions permitted under paragraph (a) of this Regulation shall be granted only to a ship engaged on a voyage where the maximum distance of the ship from the shore, the length of the voyage, the absence of general navigational hazards, and other conditions affecting safety are such as to render the full application of Regulation 3 or Regulation 4 of this Chapter unreasonable or unnecessary. When deciding whether or not to grant exemptions to individual ships, Administrations shall have regard to the effect that exemptions may have upon the general efficiency of the distress service for the safety of all ships. Administrations should bear in mind the desirability of requiring ships which are exempted from the requirement of Regulation 3 of this Chapter to be fitted with a radiotelephone station which complies with the provisions of Regulations 15 and 16 of this Chapter as a condition of exemption.
- (c) Each Administration shall submit to the Organization as soon as possible after the first of January in each year a report showing all exemptions granted under paragraphs (a) and (b) of this Regulation during the previous calendar year and giving the reasons for granting such exemptions.

PART B WATCHES

Regulation 6. Watches - Radiotelegraph

- (a) Each ship which in accordance with Regulation 3 or Regulation 4 of this Chapter is fitted with a radiotelegraph station shall, while at sea, carry at least one radio officer and, if not fitted with a radiotelegraph auto alarm shall, subject to the provisions of paragraph (d) of this Regulation, listen continuously on the radiotelegraph distress frequency by means of a radio officer using headphones or a loudspeaker.
- (b) Each passenger ship which in accordance with Regulation 3 of this Chapter is fitted with a radiotelegraph station, if fitted with a radiotelegraph auto alarm, shall, subject to the provisions of paragraph (d) of this Regulation, and while at sea, listen on the radiotelegraph distress frequency by means of a radio officer using headphones or a loudspeaker, as follows:
 - (i) if carrying or certificated to carry 250 passengers or less, at least 8 hours listening a day in the aggregate;

- (ii) if carrying or certificated to carry more than 250 passengers and engaged on a voyage exceeding 16 hours' duration between two consecutive ports, at least 16 hours' listening a day in the aggregate. In this case the ship shall carry at least two radio officers;
 - (iii) if carrying or certificated to carry more than 250 passengers and engaged on a voyage of less than 16 hours' duration between two consecutive ports, at least 8 hours' listening a day in the aggregate.
- (c) (i) Each cargo ship which in accordance with Regulation 3 of this Chapter is fitted with a radiotelegraph station, if fitted with a radiotelegraph auto alarm, shall, subject to the provisions of paragraph (d) of this Regulation, and while at sea, listen on the radiotelegraph distress frequency by means of a radio officer using headphones or a loudspeaker, for at least 8 hours a day in the aggregate.
- (ii) Each cargo ships of 300 tons gross tonnage and upwards but less than 1,600 tons gross tonnage which is fitted with a radiotelegraph station as a consequence of Regulation 4 of this Chapter, if fitted with a radiotelegraph auto alarm shall, subject to the provisions of paragraph (d) of this Regulation, and while at sea, listen on the radiotelegraph distress frequency by means of a radio officer using headphones or a loudspeaker, during such periods as may be determined by the Administration. Administrations shall, however, have regard to the desirability of requiring, whenever practicable, a listening watch of at least 8 hours a day in the aggregate.
- (d) (i) During the period when a radio officer is required by this Regulation to listen on the radiotelegraph distress frequency, the radio officer may discontinue such listening during the time when he is handling traffic on other frequencies, or performing other essential radio duties, but only if it is impracticable to listen by split headphones or loudspeaker. The listening watch shall always be maintained by a radio officer using headphones or a loudspeaker during the silence periods provided for by the Radio Regulations.

The term "essential radio duties" in this paragraph includes urgent repairs of:

- (1) equipment for radiocommunication used for safety;
 - (2) radio navigational equipment by order of the master.
- (ii) In addition to the provisions of sub-paragraph (i) of this paragraph, on ships other than multi-radio officer passenger ships, the radio officer may, in exceptional cases, i.e. when it is impractical to listen by split headphones or loudspeaker, discontinue listening by order of the master in order to carry out maintenance required to prevent imminent malfunction of:

- equipment for radiocommunication used for safety;
- radio navigational equipment;
- other electronic navigational equipment including its repair;

provided that:

- (1) the radio officer, at the discretion of the Administration concerned, is appropriately qualified to perform these duties; and
- (2) the ship is fitted with a receiving selector which meets the requirements of the Radio Regulations;
- (3) the listening watch is always maintained by a radio officer using headphones or loudspeaker during the silence periods provided for by the Radio Regulations.

- (d) In all ships fitted with a radiotelegraph auto alarm this radiotelegraph auto alarm shall, while the ship is at sea, be in operation whenever there is no listening being kept under paragraphs (b), (c) or (d) of this Regulation and, whenever practicable, during direction-finding operations.
- (e) The listening periods provided for by this Regulation, including those which are determined by the Administration, should be maintained preferably during periods prescribed for the radiotelegraph service by the Radio Regulations.

Regulation 7. Watches - Radiotelephone

- (a) Each ship which is fitted with a radiotelephone station in accordance with Regulation 4 of this Chapter shall, for safety purposes, carry at least on radiotelephone operator (who may be the master, an officer or a member of the crew holding a certificate for radiotelephony) and shall, while at sea, maintain continuous watch on the radiotelephone distress frequency in the place on board from which the ship is usually navigated, by use of a radiotelephone distress frequency watch receiver, using a loudspeaker, a filtered loudspeaker or radiotelephone auto alarm.
- (b) Each ship which in accordance with Regulation 3 or Regulation 4 of this Chapter is fitted with a radiotelegraph station shall, while at sea, maintain continuous watch on the radiotelephone distress frequency in a place to be determined by the Administration, by use of a radiotelephone distress frequency watch receiver, using a loudspeaker, a filtered loudspeaker or radiotelephone auto alarm.

Regulation 8. Watches - VHF Radiotelephone

Each ship provided with a Very High Frequency (VHF) radiotelephone station, in accordance with Regulation 18 of Chapter V, shall maintain a listening watch on the bridge for such periods and on such channels as may be required by the Contracting Government referred to in that Regulation.

PART C TECHNICAL REQUIREMENTS

Regulation 9. Radiotelegraph Stations

- (a) The radiotelegraph station shall be so located that no harmful interference from extraneous mechanical or other noise will be caused to the proper reception of radio signals. The station shall be placed as high in the ship as is practicable, so that the greatest possible degree of safety may be secured.
- (b) The radiotelegraph operating room shall be of sufficient size and of adequate ventilation to enable the main and reserve radiotelegraph installations to be operated efficiently, and shall not be used for any purpose which will interfere with the operation of the radiotelegraph station.
- (c) The sleeping accommodation of at least one radio officer shall be situated as near as practicable to the radiotelegraph operating room. In new ships, this sleeping accommodation shall not be within the radiotelegraph operating room.
- (d) There shall be provided between the radiotelegraph operating room and the bridge and one other place, if any, from which the ship is navigated, an efficient two-way system for calling and voice communication which shall be independent of the main communication system on the ship.
- (e) The radiotelegraph installation shall be installed in such a position that it will be protected against the harmful effects of water or extremes of temperature. It shall be readily accessible both for immediate use in case of distress and for repair.

- (f) A reliable clock with a dial not less than 12.5 centimetres (5 inches) in diameter and a concentric seconds hand, the face of which is marked to indicate the silence periods prescribed for the radiotelegraph service by the Radio Regulations, shall be provided. It shall be securely mounted in the radiotelegraph operating room in such a position that the entire dial can be easily and accurately observed by the radio officer from the radiotelegraph operating position and from the position for testing the radiotelegraph auto alarm receiver.
- (g) A reliable emergency light shall be provided in the radiotelegraph operating room, consisting of an electric lamp permanently arranged so as to provide satisfactory illumination of the operating controls of the main and reserve radiotelegraph installations and of the clock required by paragraph (f) of this Regulation. In new installations, this lamp shall, if supplied from the reserve source of energy required by sub-paragraph (a)(iii) of Regulation 10 of this Chapter, be controlled by two-way switches placed near the main entrance to the radiotelegraph operating room and at the radiotelegraph operation position, unless the layout of the radiotelegraph operating room does not warrant it. These switches shall be clearly labelled to indicate their purpose.
- (h) Either an electric inspection lamp, operated from the reserve source of energy required by sub-paragraph (a)(iii) of Regulation 10 of this Chapter and provided with a flexible lead of adequate length, or a flashlight shall be provided and kept in the radiotelegraph operating room.
- (i) The radiotelegraph station shall be provided with such spare parts, tools and testing equipment as will enable the radiotelegraph installation to be maintained in efficient working condition while at sea. The testing equipment shall include an instrument or instruments for measuring A.C. volts, D.C. volts and ohms.
- (j) If a separate emergency radiotelegraph operating room is provided the requirements of paragraphs (d), (e), (f), (g) and (h) of this Regulation shall apply to it.

Regulation 10. Radiotelegraph Installations

- (a) Except as otherwise expressly provided in this Regulation:
 - (i) The radiotelegraph station shall include a main installation and reserve installation, electrically separate and electrically independent of each other.
 - (ii) The main installation shall include a main transmitter, main receiver, radiotelephone distress frequency watch receiver, and main source of energy.
 - (iii) The reserve installation shall include a reserve transmitter, reserve receiver and reserve source of energy.
 - (iv) A main and a reserve antenna shall be provided and installed, provided that the Administration may except any ship from the provision of a reserve antenna if it is satisfied that the fitting of such an antenna is impracticable or unreasonable, but in such case a suitable spare antenna completely assembled for immediate installation shall be carried. In addition, sufficient antenna wire and insulators shall in all cases be provided to enable a suitable antenna to be erected. The main antenna, if suspended between supports liable to whipping, shall be suitably protected against breakage.
- (b) In installations on cargo ships (except those on cargo ships of 1,600 tons gross tonnage and upwards installed on or after 19 November 1952), if the main transmitter complies with all the requirements for the reserve transmitter, the latter is not obligatory.
- (c)
 - (i) The main and reserve transmitters shall be capable of being quickly connected with and tuned to the main antenna, and the reserve antenna if one is fitted.
 - (ii) The main and reserve receivers shall be capable of being quickly connected with any antenna with which they are required to be used.

- (d) All parts of the reserve installation shall be placed as high in the ship as is practicable, so that the greatest possible degree of safety may be secured.
- (e) The main and reserve transmitters shall be capable of transmitting on the radiotelegraph distress frequency using a class of emission assigned by the Radio Regulations for that frequency. In addition, the main transmitter shall be capable of transmitting on at least two working frequencies in the authorized bands between 405 kHz and 535 kHz, using classes of emission assigned by the Radio Regulations for these frequencies. The reserve transmitter may consist of a ship's emergency transmitter, as defined in and limited in use by the Radio Regulations.
- (f) The main and reserve transmitters shall, if modulated emission is prescribed by the Radio Regulations, have a depth of modulation of not less than 70 per cent and a note frequency between 450 and 1,350 Hz.
- (g) The main and reserve transmitters shall, when connected to the main antenna, have a minimum normal range as specified below, that is to say, they must be capable of transmitting clearly perceptible signals from ship to ship by day and under normal conditions and circumstances over the specified ranges.²⁴ (Clearly perceptible signals will normally be received if the R.M.S. value of the field strength at the receiver is at least 50 microvolts per metre.)

	<i>Minimum normal range in miles</i>	
	<i>Main transmitter</i>	<i>Reserve transmitter</i>
All passenger ships, and cargo ships of 1,600 tons gross tonnage and upwards	150	100
Cargo ships below 1,600 tons gross tonnage	100	75

- (h) (i) The main and reserve receivers shall be capable of receiving the radiotelegraph distress frequency and the classes of emission assigned by the Radio Regulations for that frequency.
- (ii) In addition, the main receiver shall permit the reception of such of the frequencies and classes of emission used for the transmission of time signals, meteorological messages and such other communications relating to safety of navigation as may be considered necessary by the Administration.

²⁴ In the absence of a direct measurement of the field strength the following data may be used as a guide for approximately determining the normal range:

<i>Normal range in miles</i>	<i>Metre-amperes*</i>	<i>Total antenna power (watts)**</i>
200	128	200
175	102	125
150	76	71
125	58	41
100	45	25
75	34	14

* This figure represents the product of the maximum height of the antenna above the deepest load water-line in metres and the antenna current in amperes (R.M.S. value). The values given in the second column of the table correspond to an average value of the ratio

$$\frac{\text{effective antenna height}}{\text{maximum antenna height}} = 0.47$$

This ratio varies with local conditions of the antenna and may vary between about 0.3 and 0.7.

**The values given in the third column of the table correspond to an average value of the ratio

$$\frac{\text{radiated antenna power}}{\text{total antenna power}} = 0.08$$

This ratio varies considerably according to the values of effective antenna height and antenna resistance.

- (iii) The radiotelephone distress frequency watch receiver shall be preset to this frequency. It shall be provided with a filtering unit or a device to silence the loudspeaker if on the bridge in the absence of a radiotelephone alarm signal. The device shall be capable of being easily switched in and out and may be used when, in the opinion of the master, conditions are such that maintenance of the listening watch would interfere with the safe navigation of the ship.
- (iv) (1) A radiotelephone transmitter, if provided, shall be fitted with an automatic device for generating the radiotelephone alarm signal, so designed as to prevent actuation by mistake, and complying with the requirements of paragraph (e) of Regulation 16 of this Chapter. The device shall be capable of being taken out of operation at any time in order to permit the immediate transmission of a distress message.
 - (2) Arrangements shall be made to check periodically the proper functioning of the automatic device for generating the radiotelephone alarm signal on frequencies other than the radiotelephone distress frequency using a suitable artificial antenna.
- (i) The main receiver shall have sufficient sensitivity to produce signals in headphones or by means of a loudspeaker when the receiver input is as low as 50 microvolts. The reserve receiver shall have sufficient sensitivity to produce such signals when the receiver input is as low as 100 microvolts.
- (j) There shall be available at all times, while the ship is at sea, a supply of electrical energy sufficient to operate the main installation over the normal range required by paragraph (g) of this Regulation as well as for the purpose of charging any batteries forming part of the radiotelegraph station. The voltage of the supply for the main installation shall, in the case of new ships, be maintained within 10 per cent of the rated voltage. In the case of existing ships, it shall be maintained as near the rated voltage as possible and, if practicable, within 10 per cent.
- (k) The reserve installation shall be provided with a source of energy independent of the propelling power of the ship and of the ship's electrical system.
- (l) (i) The reserve source of energy shall preferably consist of accumulator batteries, which may be charged from the ship's electrical system, and shall under all circumstances be capable of being put into operation rapidly and of operating the reserve transmitter and receiver for at least six hours continuously under normal working conditions besides any of the additional loads mentioned in paragraphs (m) and (n) of this Regulation.
 - (ii) The reserve source of energy is required to be of a capacity sufficient to operate simultaneously the reserve transmitter and the VHF installation, when fitted, for at least six hours unless a switching device is fitted to ensure alternate operation only. VHF usage of the reserve source of energy shall be limited to distress, urgency and safety communications. Alternatively, a separate reserve source of energy may be provided for the VHF installation.
- (m) The reserve source of energy shall be used to supply the reserve installation and the automatic alarm signal keying device specified in paragraph (r) of this Regulation if it is electrically operated.

The reserve source of energy may also be used to supply:

- (i) the radiotelegraph auto alarm;
- (ii) the emergency light specified in paragraph (g) of Regulation 9 of this Chapter;
- (iii) the direction-finder;
- (iv) the VHF installation;

- (v) the device for generating the radiotelephone alarm signal, if provided;
- (vi) any device, prescribed by the Radio Regulations, to permit changeover from transmission to reception and vice versa.

Subject to the provisions of paragraph (n) of this Regulation, the reserve source of energy shall not be used other than for the purposes specified in this paragraph.

- (n) Notwithstanding the provisions of paragraph (m) of this Regulation, the Administration may authorize the use in cargo ships of the reserve source of energy for a small number of low-power emergency circuits which are wholly confined to the upper part of the ship, such as emergency lighting on the boat deck, on condition that these can be readily disconnected if necessary, and that the source of energy is of sufficient capacity to carry the additional load or loads.
- (o) The reserve source of energy and its switchboard shall be as high as practicable in the ship and readily accessible to the radio officer. The switchboard shall, wherever possible, be situated in a radio room; if it is not, it shall be capable of being illuminated.
- (p) While the ship is at sea, accumulator batteries, whether forming part of the main installation or reserve installation, shall be brought up to the normal fully-charged condition daily.
- (q) All steps shall be taken to eliminate so far as is possible the causes of, and to suppress, radio interference from electrical and other apparatus on board. If necessary, steps shall be taken to ensure that the antennae attached to broadcast receivers do not cause interference to the efficient or correct working of the radiotelegraph installation. Particular attention shall be paid to this requirement in the design of new ships.
- (r) In addition to a means for manually transmitting the radiotelegraph alarm signal, an automatic radiotelegraph alarm signal keying device shall be provided, capable of keying the main and the reserve transmitters so as to transmit the radiotelegraph alarm signal. The device shall be capable of being taken out of operation at any time in order to permit immediate manual operation of the transmitter. If electrically operated, this keying device shall be capable of operation from the reserve source of energy.
- (s) At sea, the reserve transmitter, if not used for communications, shall be tested daily using a suitable artificial antenna, and at least once during each voyage using the reserve antenna if installed. The reserve source of energy shall also be tested daily.
- (t) All equipment forming part of the radiotelegraph installation shall be reliable, and shall be so constructed that it is readily accessible for maintenance purposes.
- (u) Notwithstanding the provisions of Regulation 4 of this Chapter, the Administration may, in the case of cargo ships of less than 1,600 tons gross tonnage, relax the full requirements of Regulation 9 of this Chapter and the present Regulation, provided that the standard of the radiotelegraph station shall in no case fall below the equivalent of that prescribed under Regulation 15 and Regulation 16 of this Chapter for radiotelephone stations, so far as applicable. In particular, in the case of cargo ships of 300 tons gross tonnage and upwards but less than 500 tons gross tonnage, the Administration need not require:
 - (i) a reserve receiver;
 - (ii) a reserve source of energy in existing installations;
 - (iii) protection of the main antenna against breakage by whipping;
 - (iv) the means of communication between the radiotelegraph station and the bridge to be independent of the main communication system;
 - (v) the range of the transmitter to be greater than 75 miles.

Regulation 11. Radiotelegraph Auto Alarms

- (a) Any radiotelegraph auto alarm installed after 26 May 1965 shall comply with the following minimum requirements:
- (i) In the absence of interference of any kind it shall be capable of being actuated, without manual adjustment, by any radiotelegraph alarm signal transmitted on the radiotelegraph distress frequency by any coast station, ship's emergency or survival craft transmitter operating in accordance with the Radio Regulations, provided that the strength of the signal at the receiver input is greater than 100 microvolts and less than 1 volt.
 - (ii) In the absence of interference of any kind, it shall be actuated by either three of four consecutive dashes when the dashes vary in length from 3.5 to as near 6 seconds as possible and the spaces vary in length between 1.5 seconds and the lowest practicable value, preferably not greater than 10 milliseconds.
 - (iii) It shall not be actuated by atmospherics or by any signal other than the radiotelegraph alarm signal, provided that the received signals do not in fact constitute a signal falling within the tolerance limits indicated in sub-paragraph (ii) above.
 - (iv) The selectivity of the radiotelegraph auto alarm shall be such as to provide a practically uniform sensitivity over a band extending not less than 4 kHz and not more than 8 kHz on each side of the radiotelegraph distress frequency and to provide outside this band a sensitivity which decreases as rapidly as possible in conformity with the best engineering practice.
 - (v) If practicable, the radiotelegraph auto alarm shall, in the presence of atmospherics or interfering signals, automatically adjust itself so that within a reasonably short time it approaches the condition in which it can most readily distinguish the radiotelegraph alarm signal.
 - (vi) When actuated by a radiotelegraph alarm signal, or in the event of failure of the apparatus, the radiotelegraph auto alarm shall cause a continuous audible warning to be given in the radiotelegraph operating room, in the radio officer's sleeping accommodation and on the bridge. If practicable, warning shall also be given in the case of failure of any part of the whole alarm receiving system. Only one switch for stopping the warning shall be provided and this shall be situated in the radiotelegraph operating room.
 - (vii) For the purpose of regularly testing the radiotelegraph auto alarm, the apparatus shall include a generator pre-tuned to the radiotelegraph distress frequency and a keying device by means of which a radiotelegraph alarm signal of the minimum strength indicated in sub-paragraph (i) above is produced. A means shall also be provided for attaching headphones for the purpose of listening to signals received on the radiotelegraph auto alarm.
 - (viii) The radiotelegraph auto alarm shall be capable of withstanding vibration, humidity and changes of temperature, equivalent to severe conditions experienced on board ships at sea, and shall continue to operate under such conditions.
- (b) Before a new type of radiotelegraph auto alarm is approved, the Administration concerned shall be satisfied, by practical tests made under operating conditions equivalent to those obtaining in practice, that the apparatus complies with paragraph (a) of this Regulation.
- (c) In ships fitted with a radiotelegraph auto alarm, its efficiency shall be tested by a radio officer at least once every 24 hours while at sea. If it is not in working order, the radio officer shall report that fact to the master or officer on watch on the bridge.
- (d) A radio officer shall periodically check the proper functioning of the radiotelegraph auto alarm receiver, with its normal antenna connected, by listening to signals and by comparing them with similar signals received on the radiotelegraph distress frequency on the main installation.

- (e) As far as practicable, the radiotelegraph auto alarm, when connected to an antenna shall not affect the accuracy of the direction-finder.

Regulation 12. Direction-Finders

- (a) (i) The direction-finding apparatus required by Regulation 12 of Chapter V shall be efficient and capable of receiving signals with the minimum of receiver noise and of taking bearings from which the true bearing and direction may be determined.
- (ii) It shall be capable of receiving signals on the radiotelegraph frequencies assigned by the Radio Regulations for the purposes of distress and direction-finding and for maritime radio beacons.
- (iii) In the absence of interference the direction-finding apparatus shall have a sensitivity sufficient to permit accurate bearings being taken on a signal having a field strength as low as 50 microvolts per metre.
- (iv) As far as is practicable, the direction-finding apparatus shall be so located that as little interference as possible from mechanical or other noise will be caused to the efficient determination of bearings.
- (v) As far as is practicable, the direction-finding antenna system shall be erected in such a manner that the efficient determination of bearings will be hindered as little as possible by the close proximity of other antennae, derricks, wire halyards or other large metal objects.
- (vi) An efficient two-way means of calling and voice communication shall be provided between the direction-finder and the bridge.
- (vii) All direction-finders shall be calibrated to the satisfaction of the Administration on first installation. The calibration shall be verified by check bearings or by a further calibration whenever any changes are made in the position of any antennae or of any structures on deck which might affect appreciably the accuracy of the direction-finder. The calibration particulars shall be checked at yearly intervals, or as near thereto as possible. A record shall be kept of the calibrations and of any checks made of their accuracy.
- (b) (i) Radio equipment for homing on the radiotelephone distress frequency shall be capable of taking direction-finding bearings on that frequency without ambiguity of sense within an arc of 30 degrees on either side of the bow.
- (ii) When installing and testing the equipment referred to in this paragraph due regard should be given to the relevant recommendation of the International Radio Consultative Committee (CCIR).
- (iii) All reasonable steps shall be taken to ensure the homing capability required by this paragraph. In cases where due to technical difficulties the homing capability cannot be achieved, Administrations may grant to individual ships exemptions from the requirements of this paragraph.

Regulation 13. Radiotelegraph Installation for Fitting in Motor Lifeboats

- (a) The radiotelegraph installation required by Regulation 14 of Chapter III shall include a transmitter, a receiver and a source of energy. It shall be so designed that it can be used in an emergency by an unskilled person.
- (b) The transmitter shall be capable of transmitting on the radiotelegraph distress frequency using a class of emission assigned by the Radio Regulations for that frequency. The transmitter shall also be capable of transmitting on the frequency, and of using a class of emission, assigned by the Radio Regulations for use by survival craft in the bands between 4,000 kHz and 27,500 kHz.

- (c) The transmitter shall, if modulated emission is prescribed by the Radio Regulations, have a depth of modulation of not less than 70 per cent and a note frequency between 450 and 1,350 Hz.
- (d) In addition to a key for manual transmissions, the transmitter shall be fitted with an automatic keying device for the transmission of the radiotelegraph alarm and distress signals.
- (e) On the radiotelegraph distress frequency the transmitter shall have a minimum normal range (as specified in paragraph (g) of Regulation 10 of this Chapter) of 25 miles using the fixed antenna.²⁵
- (f) The receiver shall be capable of receiving the radiotelegraph distress frequency and the classes of emission assigned by the Radio Regulations for that frequency.
- (g) The source of energy shall consist of an accumulator battery with sufficient capacity to supply the transmitter for four hours continuously under normal working conditions. If the battery is of a type that required charging, means shall be available for charging it from the ship's power supply. In addition there shall be a means for charging it after the lifeboat has been launched.
- (h) When the power for the radiotelegraph installation and the searchlight required by Regulation 14 of Chapter III are drawn from the same battery, it shall have sufficient capacity to provide for the additional load of the searchlight.
- (i) A fixed-type antenna will be provided together with means for supporting it at the maximum practicable height. In addition an antenna supported by a kite or balloon shall be provided if practicable.
- (j) At sea a radio officer shall at weekly intervals test the transmitter using a suitable artificial antenna, and shall bring the battery up to full charge if it is of a type which requires charging.

Regulation 14. Portable Radio Apparatus for Survival Craft

- (a) The apparatus required by Regulation 13 of Chapter III shall include a transmitter, a receiver, an antenna and a source of energy. It shall be so designed that it can be used in an emergency by an unskilled person.
- (b) The apparatus shall be readily portable, watertight, capable of floating in sea water and capable of being dropped into the sea without damage. New equipment shall be as light-weight and compact as practicable and shall preferably be capable of use in both lifeboats and liferafts.
- (c) The transmitter shall be capable of transmitting on the radiotelegraph distress frequency using a class of emission assigned by the Radio Regulations for that frequency, and, in the bands between 4,000 kHz and 27,500 kHz, of transmitting on the radiotelegraph frequency, and of using a class of emission assigned by the Radio Regulations for survival craft. However, the Administration may permit the transmitter to be capable of transmitting on the radiotelephone distress frequency, and of using a class of emission assigned by the Radio Regulations for that frequency, as an alternative or in addition to transmission on the radiotelegraph frequency assigned by the Radio Regulations for survival craft in the bands between 4,000 kHz and 27,500 kHz.
- (d) The transmitter shall, if modulated emission is prescribed by the Radio Regulations, have a depth of modulation of not less than 70 per cent and in the case of radiotelegraph emission have a note frequency between 450 and 1,350 Hz.
- (e) In addition to a key for manual transmissions, the transmitter shall be fitted with an automatic keying device for the transmission of the radiotelegraph alarm and distress signals. If the

²⁵ In the absence of a measurement of the field strength, it may be assumed that this range will be obtained if the product of the height of the antenna above the water-line and the antenna current (R.M.S. value) is 10 metre-amperes.

transmitter is capable of transmitting on the radiotelephone distress frequency, it shall be fitted with an automatic device, complying with the requirements of paragraph (e) of Regulation 16 of this Chapter, for transmitting the radiotelephone alarm signal.

- (f) The receiver shall be capable of receiving the radiotelegraph distress frequency and the classes of emission assigned by the Radio Regulations for that frequency. If the transmitter is capable of transmitting on the radiotelephone distress frequency the receiver shall also be capable of receiving that frequency and a class of emission assigned by the Radio Regulations for that frequency.
- (g) The antenna shall be either self-supporting or capable of being supported by the mast of a lifeboat at the maximum practicable height. In addition it is desirable that an antenna supported by a kite or balloon shall be provided if practicable.
- (h) The transmitter shall supply an adequate radio frequency power²⁶ to the antenna required by paragraph (a) of this Regulation and shall preferably derive its supply from a hand generator. If operated from a battery, the battery shall comply with conditions laid down by the Administration to ensure that it is of a durable type and is of adequate capacity.
- (i) At sea a radio officer or a radiotelephone operator, as appropriate, shall at weekly intervals test the transmitter, using a suitable artificial antenna and shall bring the battery up to full charge if it is of a type which requires charging.
- (j) For the purpose of this Regulation, new equipment means equipment supplied to a ship after the date of entry into force of the present Convention.

Regulation 15. Radiotelephone Stations

- (a) The radiotelephone station shall be in the upper part of the ship and so located that it is sheltered to the greatest possible extent from noise which might impair the correct reception of messages and signals.
- (b) There shall be efficient communication between the radiotelephone station and the bridge.
- (c) A reliable clock shall be securely mounted in such a position that the entire dial can be easily observed from the radiotelephone operating position.
- (d) A reliable emergency light shall be provided, independent of the system which supplies the normal lighting of the radiotelephone installation, and permanently arranged so as to be capable of providing adequate illumination of the operating controls of the radiotelephone installation, of the clock required by paragraph (c) of this Regulation and of the card of instructions required by paragraph (f).
- (e) Where a source of energy consists of a battery or batteries, the radiotelephone station shall be provided with a means of assessing the charge condition.
- (f) A card of instructions giving a clear summary of the radiotelephone distress procedure shall be displayed in full view of the radiotelephone operating position.

Regulation 16. Radiotelephone Installations

- (a) The radiotelephone installation shall include transmitting and receiving equipment, and appropriate sources of energy (referred to in the following paragraphs as "the transmitter", "the receiver", "the radiotelephone distress frequency watch receiver", and "the source of energy" respectively).

²⁶ It may be assumed that the purposes of this Regulation will be satisfied by the following performance: At least 10 watts input to the anode of the final stage or a radio-frequency output of at least 2.0 watts (A2 emission) at 500 kHz into an artificial antenna having an effective resistance of 15 ohms and 100 X 10⁻¹² farads capacitance in series. The depth of modulation shall be at least 70 per cent.

- (b) The transmitter shall be capable of transmitting on the radiotelephone distress frequency and on at least one other frequency in the bands between 1,605 kHz and 2,850 kHz, using the classes of emission assigned by the Radio Regulations for these frequencies. In normal operation a double sideband transmission or a single sideband transmission with full carrier (i.e., A3H) shall have a depth of modulation of at least 70 per cent at peak intensity. Modulation of a single sideband transmission with reduced or suppressed carrier (A3A, A3J) shall be such that the intermodulation products shall not exceed the values given in the Radio Regulations.
- (c) (i) In the case of cargo ships of 500 tons gross tonnage and upwards but less than 1,600 tons gross tonnage the transmitter shall have a minimum normal range of 150 miles, i.e., it shall be capable of transmitting clearly perceptible signals from ship to ship by day and under normal conditions and circumstances over this range.²⁷ (Clearly perceptible signals will normally be received if the R.M.S. value of the field strength produced at the receiver by the unmodulated carrier is at least 25 microvolts per metre.)
- (ii) In the case of cargo ships of 300 tons gross tonnage and upwards but less than 500 tons gross tonnage:
- (1) for existing installations the transmitter shall have a minimum normal range of at least 75 miles; and
 - (2) for new installations the transmitter shall produce a power in the antenna of at least 15 watts (unmodulated carrier).
- (d) The transmitter shall be fitted with a device for generating the radiotelephone alarm signal by automatic means so designed as to prevent actuation by mistake. The device shall be capable of being taken out of operation at any time in order to permit the immediate transmission of a distress message. Arrangements shall be made to check periodically the proper functioning of the device on frequencies other than the radiotelephone distress frequency using a suitable artificial antenna.
- (e) The device required by paragraph (d) of this Regulation shall comply with the following requirements:
- (i) The tolerance of the frequency of each tone shall be 1.5 per cent.
 - (ii) The tolerance on the duration of each tone shall be 50 milliseconds.
 - (iii) The interval between successive tones shall not exceed 50 milliseconds.
 - (iv) The ratio of the amplitude of the stronger tone to that of the weaker shall be within the range 1 to 1.2.
- (f) The receiver required by paragraph (a) of this Regulation shall be capable of receiving the radiotelephone distress frequency and at least one other frequency available for maritime radiotelephone stations in the bands between 1,605 kHz and 2,850 kHz, using the classes of emission assigned by the Radio Regulations for these frequencies. In addition the receiver shall permit the reception of such other frequencies, using the classes of emission assigned by the Radio Regulations, as are used for the transmission by radiotelephony of meteorological messages and such other communications relating to the safety of navigation as may be considered necessary by the Administration. The receiver shall have sufficient sensitivity to produce signals by means of a loudspeaker when the receiver input is as low as 50 microvolts.
- (g) The radiotelephone distress frequency watch receiver shall be preset to this frequency. It shall be provided with a filtering unit or a device to silence the loudspeaker in the absence of a radiotelephone alarm signal. The device shall be capable of being easily switched in and out

²⁷ In the absence of field strength measurements, it may be assumed that this range will be obtained by a power in the antenna of 15 watts (unmodulated carrier) with an antenna efficiency of 27 per cent.

and may be used when, in the opinion of the master, conditions are such that maintenance of the listening watch would interfere with the safe navigation of the ship.

- (h) To permit rapid change-over from transmission to reception when manual switching is used, the control for the switching device shall, where practicable, be located on the microphone or the telephone handset.
- (i) While the ship is at sea, there shall be available at all times a main source of energy sufficient to operate the installation over the normal range required by paragraph (c) of this Regulation. If batteries are provided they shall under all circumstances have sufficient capacity to operate the transmitter and receiver for at least six hours continuously under normal working conditions.²⁸ In installations in cargo ships of 500 tons gross tonnage and upwards but less than 1,600 tons gross tonnage made on or after 19 November 1952, a reserve source of energy shall be provided in the upper part of the ship unless the main source of energy is so situated.
- (j) The reserve source of energy, if provided, may be used only to supply:
 - (i) the radiotelephone installation;
 - (ii) the emergency light required by paragraph (d) of Regulation 15 of this Chapter;
 - (iii) the device required by paragraph (d) of this Regulation, for generating the radiotelephone alarm signal; and
 - (iv) the VHF installation.
- (k) Notwithstanding the provisions of paragraph (j) of this Regulation, the Administration may authorize the use of the reserve source of energy, if provided, for a direction-finder, if fitted, and for a number of low-power emergency circuits which are wholly confined to the upper part of the ship, such as emergency lighting on the boat deck, on condition that the additional loads can be readily disconnected, and that the source of energy is of sufficient capacity to carry them.
- (l) While at sea, any battery provided shall be kept charged so as to meet the requirements of paragraph (i) of this Regulation.
- (m) An antenna shall be provided and installed and, if suspended between supports liable to whipping, shall in the case of cargo ships of 500 tons gross tonnage and upwards but less than 1,600 tons gross tonnage be protected against breakage. In addition, there shall be a spare antenna completely assembled for immediate replacement or, where this is not practicable, sufficient antenna wire and insulators to enable a spare antenna to be erected. The necessary tools to erect an antenna shall also be provided.

Regulation 17. VHF Radiotelephone Stations

- (a) When a VHF radiotelephone station is provided in accordance with Regulation 18 of Chapter V, it shall be in the upper part of the ship and include a VHF radiotelephone installation complying with the provisions of this Regulation and comprising a transmitter and receiver, a source of power capable of actuating them at their rated power levels, and an antenna suitable for efficient radiating and receiving signals at the operating frequencies.
- (b) Such a VHF installation shall conform to the requirements laid down in the Radio Regulations for equipment used in the VHF Maritime Mobile Radiotelephone Service and shall be capable

²⁸ For the purpose of determining the electrical load to be supplied by batteries required to have six hours reserve capacity, the following formula is recommended as a guide:

- ½ of the current consumption necessary for speech transmission;
- + current consumption of receiver;
- + current consumption of all additional loads to which the batteries may supply energy in time of distress or emergency.

of operation on those channels specified by the Radio Regulations and as may be required by the Contracting Government referred to in Regulation 18 of Chapter V.

- (c) The Contracting Government shall not require the transmitter R.F. carrier power output to be greater than 10 watts. The antenna shall, in so far as is practicable, have an unobstructed view in all directions.
- (d) Control of the VHF channels required for navigational safety shall be immediately available on the bridge convenient to the conning position and, where necessary, facilities should also be available to permit radiocommunications from the wings of the bridge.

Regulation 18. Radiotelephone Auto Alarms

- (a) The radiotelephone auto alarm shall comply with the following minimum requirements:
 - (i) the frequencies of maximum response of the tuned circuits, and other tone selecting devices, shall be subject to a tolerance of 1.5 per cent in each instance; and the response shall not fall below 50 per cent of the maximum response for frequencies within 3 per cent of the frequency of maximum response;
 - (ii) in the absence of noise and interference, the automatic receiving equipment shall be capable of operating from the alarm signal in a period of not less than four and not more than six seconds;
 - (iii) the automatic receiving equipment shall respond to the alarm signal, under conditions of intermittent interference caused by atmospherics and powerful signals other than the alarm signal, preferably without any manual adjustment being required during any period of watch maintained by the equipment;
 - (iv) the automatic receiving equipment shall not be actuated by atmospherics or by strong signals other than the alarm signal;
 - (v) the automatic receiving equipment shall be effective beyond the range at which speech transmission is satisfactory;
 - (vi) the automatic receiving equipment shall be capable of withstanding vibration, humidity, changes of temperature and variations in power supply voltage equivalent to the severe conditions experienced on board ships at sea, and shall continue to operate under such conditions;
 - (vii) the automatic receiving equipment should, as far as practicable, give warning of faults that would prevent the apparatus from performing its normal functions during watch hours.
- (b) Before a new type of radiotelephone auto alarm is approved, the Administration concerned shall be satisfied by practical tests, made under operating conditions equivalent to those obtained in practice, that the apparatus complies with paragraph (a) of this Regulation.

PART D RADIO LOGS

Regulation 19. Radio Logs

- (a) The radio log (diary of the radio service) required by the Radio Regulations for a ship which is fitted with a radiotelegraph station in accordance with Regulation 3 or Regulation 4 of this Chapter shall be kept in the radiotelegraph operating room during the voyage. Every radio officer shall enter in the log his name, the times at which he goes on and off watch, and all incidents connected with the radio service which occur during his watch which may appear to be of importance to safety of life at sea. In addition, there shall be entered in the log:
 - (i) the entries required by the Radio Regulations;

- (ii) details of the maintenance, including a record of the charging of the batteries, in such form as may be prescribed by the Administration;
 - (iii) a daily statement that the requirement of paragraph (p) of Regulation 10 of this Chapter has been fulfilled;
 - (iv) details of the tests of the reserve transmitter and reserve source of energy made under paragraph (s) of Regulation 10 of this Chapter;
 - (v) in ships fitted with a radiotelegraph auto alarm details of tests made under paragraph (c) of Regulation 11 of this Chapter;
 - (vi) details of the maintenance of the batteries, including a record of the charging (if applicable) required by paragraph (j) of Regulation 13 of this Chapter, and details of the tests required by that paragraph in respect of the transmitters fitted in motor lifeboats;
 - (vii) details of the maintenance of the batteries, including a record of the charging (if applicable) required by paragraph (i) of Regulation 14 of this Chapter, and details of the tests required by that paragraph in respect of portable radio apparatus for survival craft;
 - (viii) the time at which the listening watch was discontinued in accordance with paragraph (d) of Regulation 6 of this Chapter, together with the reason and the time at which the listening watch was resumed.
- (b) The radio log (diary of the radio service) required by the Radio Regulations for a ship which is fitted with a radiotelephone station in accordance with Regulation 4 of this Chapter shall be kept at the place where listening watch is maintained. Every qualified operator, and every master, officer or crew member carrying out a listening watch in accordance with Regulation 7 of this Chapter, shall enter in the log, with his name, the details of all incidents connected with the radio service which occur during his watch which may appear to be of importance to safety of life at sea. In addition, there shall be entered in the log:
- (i) the details required by the Radio Regulations;
 - (ii) the time at which listening watch begins when the ship leaves port, and the time at which it ends when the ship reaches port;
 - (iii) the time at which listening watch is for any reason discontinued, together with the reason, and the time at which listening watch is resumed;
 - (iv) details of the maintenance of the batteries (if provided), including a record of the charging required by paragraph (l) of Regulation 16 of this Chapter;
 - (v) details of the maintenance of the batteries, including a record of the charging (if applicable) required by paragraph (i) of Regulation 14 of this Chapter, and details of the tests required by that paragraph in respect of portable radio apparatus for survival craft.
- (c) Radio logs shall be available for inspection by the officers authorized by the Administration to make such inspection.

CHAPTER V

SAFETY OF NAVIGATION

Regulation 1. Application

This Chapter, unless otherwise expressly provided in this Chapter, applies to all ships on all voyages, except ships of war and ships solely navigating the Great Lakes of North America and their connecting and tributary waters as far east as the lower exit of the St. Lambert Lock at Montreal in the Province of Quebec, Canada.

Regulation 2. Danger Messages

- (a) The master of every ship which meets with dangerous ice, a dangerous derelict, or any other direct dangers to navigation, or a tropical storm, or encounters sub-freezing air temperatures associated with gale force winds causing severe ice accretion on superstructures, or winds of force 10 or above on the Beaufort scale for which no storm warning has been received, is bound to communicate the information by all the means at his disposal to ships in the vicinity, and also to the competent authorities at the first point on the coast with which he can communicate. The form in which the information is sent is not obligatory. It may be transmitted either in plain language (preferably English) or by means of the International Code of Signals. It should be broadcast to all ships in the vicinity and sent to the first point on the coast to which communication can be made, with a request that it be transmitted to the appropriate authorities.
- (b) Each Contracting Government will take all steps necessary to ensure that when intelligence of any of the dangers specified in paragraph (a) of this Regulation is received, it will be promptly brought to the knowledge of those concerned and communicated to other interested Governments.
- (c) The transmission of messages respecting the dangers specified is free of cost to the ships concerned.
- (d) All radio messages issued under paragraph (a) of this Regulation shall be preceded by the Safety Signal, using the procedure as prescribed by the Radio Regulations as defined in Regulation 2 of Chapter IV.

Regulation 3. Information Required in Danger Messages

The following information is required in danger messages:

- (a) *Ice, derelicts and other direct dangers to navigation*
 - (i) The kind of ice, derelict or danger observed.
 - (ii) The position of the ice, derelict or danger when last observed.
 - (iii) The time and date (Greenwich Mean Time) when danger last observed.
- (b) *Tropical storms (Hurricanes in the West Indies, Typhoons in the China Sea, Cyclones in Indian waters, and storms of a similar nature in other regions)*
 - (i) A statement that a tropical storm has been encountered. The obligation should be interpreted in a broad spirit, and information transmitted whenever the master has good reason to believe that a tropical storm is developing or exists in his neighbourhood.
 - (ii) Time, date (Greenwich Mean Time) and position of ship when the observation was taken.
 - (iii) As much of the following information as is practicable should be included in the message:
 - barometric pressure, preferably corrected (stating millibars, millimetres, or inches, and whether corrected or uncorrected);

- barometric tendency (the change in barometric pressure during the past three hours);
- true wind direction;
- wind force (Beaufort scale);
- state of the sea (smooth, moderate, rough, high);
- swell (slight, moderate, heavy) and the true direction from which it comes. Period or length of swell (short, average, long) would also be of value;
- true course and speed of ship.

(c) *Subsequent observations*

When a master has reported a tropical or other dangerous storm, it is desirable, but not obligatory, that further observations be made and transmitted hourly, if practicable, but in any case at intervals of not more than three hours, so long as the ship remains under the influence of the storm.

(d) *Winds of force 10 or above on the Beaufort scale for which no storm warning has been received*

This is intended to deal with storms other than the tropical storms referred to in paragraph (b) of this Regulation; when such a storm is encountered, the message should contain similar information to that listed under that paragraph but excluding the details concerning sea and swell.

(e) *Sub-freezing air temperatures associated with gale force winds causing severe ice accretion on superstructures*

- (i) Time and date (Greenwich Mean Time).
- (ii) Air temperature.
- (iii) Sea temperature (if practicable).
- (iv) Wind force and direction.

Examples

Ice. TTT Ice. Large berg sighted in 4605 N., 4410 W., at 0800 GMT. May 15.

Derelicts. TTT Derelict. Observed derelict almost submerged in 4006 N., 1243 W., at 1630 GMT. April 21.

Danger to navigation. TTT Navigation. Alpha lightship not on station. 1800 GMT. January 3.

Tropical storm

- TTT Storm. 0030 GMT. August 18. 2004 N., 11354 E. Barometer corrected 994 millibars, tendency down 6 millibars. Wind NW., force 9, heavy squalls. Heavy easterly swell. Course 067, 5 knots.
- TTT Storm. Appearances indicate approach of hurricane. 1300 GMT. September 14. 2200 N., 7236 W. Barometer corrected 29.64 inches, tendency down .015 inches. Wind NE., force 8, frequent rain squalls. Course 035, 9 knots.
- TTT Storm. Conditions indicate intense cyclone has formed. 0200 GMT. May 4. 1620 N., 9203 E. Barometer uncorrected 753 millimetres, tendency down 5 millimetres. Wind S. by W., force 5. Course 300, 8 knots.
- TTT Storm. Typhoon to southeast. 0300 GMT. June 12. 1812 N., 12605 E. Barometer falling rapidly. Wind increasing from N.
- TTT Storm. Wind force 11, no storm warning received. 0300 GMT. May 4. 4830 N., 30 W. Barometer corrected 983 millibars, tendency down 4 millibars. Wind SW., force 11 veering. Course 260, 6 knots.

Icing. TTT experiencing severe icing. 1400 GMT. March 2. 69 N., 10 W. Air temperature 18. Sea temperature 29. Wind NE., force 8.

Regulation 4. Meteorological Services

- (a) The Contracting Governments undertake to encourage the collection of meteorological data by ships at sea and to arrange for their examination, dissemination and exchange in the manner most suitable for the purpose of aiding navigation. Administrations shall encourage the use of instruments of a high degree of accuracy, and shall facilitate the checking of such instruments upon request.
- (b) In particular, the Contracting Governments undertake to co-operate in carrying out, as far as practicable, the following meteorological arrangements:
 - (i) To warn ships of gales, storms and tropical storms, both by the issue of radio messages and by the display of appropriate signals at coastal points.
 - (ii) To issue daily, by radio, weather bulletins suitable for shipping, containing data of existing weather, waves and ice, forecasts and, when practicable, sufficient additional information to enable simple weather charts to be prepared at sea and also to encourage the transmission of suitable facsimile weather charts.
 - (iii) To prepare and issue such publications as may be necessary for the efficient conduct of meteorological work at sea and to arrange, if practicable, for the publication and making available of daily weather charts for the information of departing ships.
 - (iv) To arrange for selected ships to be equipped with tested instruments (such as a barometer, a barograph, a psychrometer, and suitable apparatus for measuring sea temperature) for use in this service, and to take meteorological observations at main standard times for surface synoptic observations (at least four times daily, whenever circumstances permit) and to encourage other ships to take observations in a modified form, particularly when in areas where shipping is sparse; these ships to transmit their observations by radio for the benefit of the various official meteorological services, repeating the information for the benefit of ships in the vicinity. When in the vicinity of a tropical storm, or of a suspected tropical storm, ships should be encouraged to take and transmit their observations at more frequent intervals whenever practicable, bearing in mind navigational preoccupations of ships' officers during storm conditions.
 - (v) To arrange for the reception and transmission by coast radio stations of weather messages from and to ships. Ships which are unable to communicate direct with shore shall be encouraged to relay their weather messages through ocean weather ships or through other ships which are in contact with shore.
 - (vi) To encourage all masters to inform ships in the vicinity and also shore stations whenever they experience a wind speed of 50 knots or more (force 10 on the Beaufort scale).
 - (vii) To endeavour to obtain a uniform procedure in regard to the international meteorological services already specified, and, as far as is practicable, to conform to the Technical Regulations and recommendations made by the World Meteorological Organization, to which the Contracting Governments may refer for study and advice any meteorological question which may arise in carrying out the present Convention.
- (c) The information provided for in this Regulation shall be furnished in form for transmission and transmitted in the order of priority prescribed by the Radio Regulations, and during transmission "to all stations" of meteorological information, forecasts and warnings, all ship stations must conform to the provisions of the Radio Regulations.

- (d) Forecasts, warnings, synoptic and other meteorological reports intended for ships shall be issued and disseminated by the national service in the best position to serve various zones and areas, in accordance with mutual arrangements made by the Contracting Governments concerned.

Regulation 5 Ice Patrol Service

- (a) The Contracting Governments undertake to continue an ice patrol and a service for study and observation of ice conditions in the North Atlantic. During the whole of the ice season the south-eastern, southern and south-western limits of the regions of icebergs in the vicinity of the Grand Banks of Newfoundland shall be guarded for the purpose of informing passing ships of the extent of this dangerous region; for the study of ice conditions in general; and for the purpose of affording assistance to ships and crews requiring aid within the limits of operation of the patrol ships. During the rest of the year the study and observation of ice conditions shall be maintained as advisable.
- (b) Ships and aircraft used for the ice patrol service and the study and observation of ice conditions may be assigned other duties by the managing Government, provided that such other duties do not interfere with their primary purpose or increase the cost of this service.

Regulation 6. Ice Patrol; Management and Cost

- (a) The Government of the United States of America agrees to continue the management of the ice patrol service and the study and observation of ice conditions, including the dissemination of information received therefrom. The Contracting Governments specially interested in these services undertake to contribute to the expense of maintaining and operating these services; each contribution to be based upon the total gross tonnage of the vessels of each contributing Government passing through the regions of icebergs guarded by the Ice Patrol; in particular, each Contracting Government specially interested undertakes to contribute annually to the expense of maintaining and operating these services a sum determined by the ratio which the total gross tonnage of that Contracting Government's vessels passing during the ice season through the regions of icebergs guarded by the Ice Patrol bears to the combined total gross tonnage of the vessels of all contributing Governments passing during the ice season through the regions of icebergs guarded by the Ice Patrol. Non-contracting Governments specially interested may contribute to the expense of maintaining and operating these services on the same basis. The managing Government will furnish annually to each contributing Government a statement of the total cost of maintaining and operating the Ice Patrol and the proportionate share of each contributing Government.
- (b) Each of the contributing Governments has the right to alter or discontinue its contribution, and other interested Governments may undertake to contribute to the expense. The contributing Government which avails itself of this right will continue responsible for its current contribution up to 1 September following the date of giving notice of intention to alter or discontinue its contribution. To take advantage of the said right it must give notice to the managing Government at least six months before the said 1 September.
- (c) If, at any time, the United States Government should desire to discontinue these services, or if one of the contributing Governments should express a wish to relinquish responsibility for its pecuniary contribution, or to have its contribution altered, or another Contracting Government should desire to undertake to contribute to the expense, the contributing Governments shall settle the question in accordance with their mutual interests.
- (d) The contributing Governments shall have the right by common consent to make from time to time such alterations in the provisions of this Regulation and of Regulation 5 of this Chapter as appear desirable.

- (e) Where this Regulation provides that a measure may be taken after agreement among the contributing Governments, proposals made by any Contracting Government for effecting such a measure shall be communicated to the managing Government which shall approach the other contributing Governments with a view to ascertaining whether they accept such proposals, and the results of the enquiries thus made shall be sent to the other contributing Governments and the Contracting Government making the proposals. In particular, the arrangements relating to contributions to the cost of the services shall be reviewed by the contributing Governments at intervals not exceeding three years. The managing Government shall initiate the action necessary to this end.

Regulation 7. Speed Near Ice

When ice is reported on or near his course the master of every ship at night is bound to proceed at a moderate speed or to alter his course so as to go well clear of the danger zone.

Regulation 8. Routing

- (a) The practice of following, particularly in converging areas, routes adopted for the purpose of separation of traffic including avoidance of passage through areas designated as areas to be avoided by ships or certain classes of ships, or for the purpose of avoiding unsafe conditions, has contributed to the safety of navigation and is recommended for use by all ships concerned.
- (b) The Organization is recognized as the only international body for establishing and adopting measures on an international level concerning routing and areas to be avoided by ships or certain classes of ships. It will collate and disseminate to Contracting Governments all relevant information.
- (c) The selection of the routes and the initiation of action with regard to them, and the delineation of what constitutes converging areas, will be primarily the responsibility of the Governments concerned. In the development of routing schemes which impinge upon international waters, or such other schemes they may wish adopted by the Organization, they will give due consideration to relevant information published by the Organization.
- (d) Contracting Governments will use their influence to secure the appropriate use of adopted routes and will do everything in their power to ensure adherence to the measures adopted by the Organization in connexion with routing of ships.
- (e) Contracting Governments will also induce all ships proceeding on voyages in the vicinity of the Grand Banks of Newfoundland to avoid, as far as practicable, the fishing banks of Newfoundland north of latitude 43°N and to pass outside regions known or believed to be endangered by ice.

Regulation 9. Misuse of Distress Signals

The use of an international distress signal, except for the purpose of indicating that a ship or aircraft is in distress, and the use of any signal which may be confused with an international distress signal, are prohibited on every ship or aircraft.

Regulation 10. Distress Messages - Obligations and Procedures

- (a) The master of a ship at sea, on receiving a signal from any source that a ship or aircraft or survival craft thereof is in distress, is bound to proceed with all speed to the assistance of the persons in distress informing them if possible that he is doing so. If he is unable or, in the special circumstances of the case, considers it unreasonable or unnecessary to proceed to their assistance, he must enter in the logbook the reason for failing to proceed to the assistance of the persons in distress.

- (b) The master of a ship in distress, after consultation, so far as may be possible, with the masters of the ships which answer his call for assistance, has the right to requisition such one or more of those ships as he considers best able to render assistance, and it shall be the duty of the master or masters of the ship or ships requisitioned to comply with the requisition by continuing to proceed with all speed to the assistance of persons in distress.
- (c) The master of a ship shall be released from the obligation imposed by paragraph (a) of this Regulation when he learns that one or more ships other than his own have been requisitioned and are complying with the requisition.
- (d) The master of a ship shall be released from the obligation imposed by paragraph (a) of this Regulation, and, if his ship has been requisitioned, from the obligation imposed by paragraph (b) of this Regulation, if he is informed by the persons in distress or by the master of another ship which has reached such persons that assistance is no longer necessary.
- (e) The provisions of this Regulation do not prejudice the International Convention for the unification of certain rules of law relating to Assistance and Salvage at Sea, signed at Brussels on 23 September 1910, particularly the obligation to render assistance imposed by Article 11 of that Convention.

Regulation 11. Signalling Lamps

All ships of over 150 tons gross tonnage, when engaged on international voyages, shall have on board an efficient daylight signalling lamp which shall not be solely dependent upon the ship's main source of electrical power.

Regulation 12. Shipborne Navigational Equipment

- (a) All ships of 1,600 tons gross tonnage and upwards shall be fitted with a radar of a type approved by the Administration. Facilities for plotting radar readings shall be provided on the bridge in those ships.
- (b) All ships of 1,600 tons gross tonnage and upwards, when engaged on international voyages, shall be fitted with radio direction-finding apparatus complying with the provisions of Regulation 12 of Chapter IV. The Administration may, in areas where it considers it unreasonable or unnecessary for such apparatus to be carried, exempt any ship of less than 5,000 tons gross tonnage from this requirement, due regard being had to the fact that radio direction-finding apparatus is of value both as a navigational instrument and as an aid to locating ships, aircraft or survival craft.
- (c) All ships of 1,600 tons gross tonnage and upwards, when engaged on international voyages, shall be fitted with a gyro-compass in addition to the magnetic compass. The Administration, if it considers it unreasonable or unnecessary to require a gyro-compass, may exempt any ship of less than 5,000 tons gross tonnage from this requirement.
- (d) All new ships of 500 tons gross tonnage and upwards, when engaged on international voyages, shall be fitted with an echo-sounding device.
- (e) Whilst all reasonable steps shall be taken to maintain the apparatus in an efficient condition, malfunction of the radar equipment, the gyro-compass or the echo-sounding device shall not be considered as making the ship unseaworthy or as a reason for delaying the ship in ports where repair facilities are not readily available.
- (f) All new ships of 1,600 tons gross tonnage and upwards, when engaged on international voyages, shall be fitted with radio equipment for homing on the radiotelephone distress frequency complying with the relevant provisions of paragraph (b) of Regulation 12 of Chapter IV.

Regulation 13. Manning

The Contracting Governments undertake, each for its national ships, to maintain, or, if it is necessary, to adopt, measures for the purpose of ensuring that, from the point of view of safety of life at sea, all ships shall be sufficiently and efficiently manned.

Regulation 14. Aids to Navigation

The Contracting Governments undertake to arrange for the establishment and maintenance of such aids to navigation, including radio beacons and electronic aids as, in their opinion, the volume of traffic justifies and the degree of risk requires, and to arrange for information relating to these aids to be made available to all concerned.

Regulation 15. Search and Rescue

- (a) Each Contracting Government undertakes to ensure that any necessary arrangements are made for coast watching and for the rescue of persons in distress at sea round its coasts. These arrangements should include the establishment, operation and maintenance of such maritime safety facilities as are deemed practicable and necessary having regard to the density of the seagoing traffic and the navigational dangers and should, so far as possible, afford adequate means of locating and rescuing such persons.
- (b) Each Contracting Government undertakes to make available information concerning its existing rescue facilities and the plans for changes therein, if any.

Regulation 16. Life-Saving Signals

The following signals shall be used by life-saving stations and maritime rescue units when communicating with ships or persons in distress and by ships or persons in distress when communicating with life-saving stations and maritime rescue units. The signals used by aircraft engaged in search and rescue operations to direct ships are indicated in paragraph (d) below. An illustrated table describing the signals listed below shall be readily available to the officer of the watch of every ship to which this Chapter applies.

- (a) Replies from life-saving stations or maritime rescue units to distress signals made by a ship or person:

<i>Signal</i>	<i>Signification</i>
<p><i>By day</i> – Orange smoke signal or combined light and sound signals (thunderlight) consisting of three single signals which are fired at intervals of approximately one minute</p> <p><i>By night</i> – White star rocket consisting of three single signals which are fired at intervals of approximately one minute.</p>	<p>"You are seen – assistance will be given as soon as possible" (Repetition of such signals shall have the same meaning)</p>

If necessary the day signals may be given at night or the night signals by day.

(b) Landing signals for the guidance of small boats with crews or persons in distress:

<i>Signal</i>	} <i>Signification</i>
<p><i>By day</i> – Vertical motion of a white flag or the arms or firing of a green star – signals or signaling the code letter "K" (– · –) given by light or sound signal apparatus</p> <p><i>By night</i> – Vertical motion of a white light or flare, or firing of a green star signal or signalling the code letter "K" (– · –) given by light or sound signal apparatus. A range (indication of direction) may be given by placing a steady white light or flare at a lower level and in line with the observer</p>	
<i>Signal</i>	} <i>Signification</i>
<p><i>By day</i> – Horizontal motion of a white flag or arms extended horizontally or firing of a red star – signal or signalling the code letter "S" (···) given by light or sound – signal apparatus.</p> <p><i>By night</i> – Horizontal motion of a white light or flare or firing of a red star – signal or signalling the code letter "S" (···) given by light or sound – signal apparatus.,</p>	
<i>Signal</i>	} <i>Signification</i>
<p><i>By day</i> – Horizontal motion of a white flag, followed by the placing of the white flag in the ground and the carrying of another white flag in the direction to be indicated or firing of a red star – signal vertically and a white star – signal in the direction towards the better landing place or signalling the code letter "S" (···) followed by the code letter "R" (· – ·) if a better landing place for the craft in distress is located more to the right in the direction of approach or the code letter "L" (· – ·) if a better landing place for the craft in distress is located more to the left in the direction of approach</p> <p><i>By night</i> – Horizontal motion of a white light or flare, followed by the placing of the white light or flare on the ground and the carrying of another white light or flare in the direction to be indicated or firing of a red star – signal vertically and a white star – signal in the direction towards the better landing place or signalling the code letter "S" (···) followed by code letter "R" (· – ·) if a better landing place for the craft in distress is located more to the right in the direction of approach or the code letter "L" (· – ·) if a better landing place for the craft in distress is located more to the left in the direction of approach</p>	

(c) Signals to be employed in connexion with the use of shore life-saving apparatus:

<i>Signal</i>	<i>Signification</i>
<p style="text-align: center;"><i>Signal</i></p> <p><i>By day</i> – Vertical motion of a white flag or the arms or firing of a green star – signal.</p> <p><i>By night</i> – Vertical motion of a white light or flare or firing of a green star – signal</p>	<p>Generally: "Affirmative."</p> <p>Specifically: "Rocket line is held." "Tail bloc is made fast." "Hawser is made fast." "Man is in the breeches buoy." "Haul away."</p>

<i>Signal</i>	<i>Signification</i>
<p style="text-align: center;"><i>Signal</i></p> <p><i>By day</i> – Horizontal motion of a white flag or the arms or firing of a red star – signal.</p> <p><i>By night</i> – Horizontal motion of a white light or flare or firing of a red star – signal</p>	<p>Generally: "Negative."</p> <p>Specifically: "Slack away." "Avast Hauling."</p>

(d) Signals used by aircraft engaged on search and rescue operations to direct ships towards an aircraft, ship or person in distress (see explanatory Note below):

(i) The following procedures performed in sequence by an aircraft mean that the aircraft is directing a surface craft towards an aircraft or a surface craft in distress:

- (1) circling the surface craft at least once;
- (2) crossing the projected course of the surface craft close ahead at a low altitude, opening and closing the throttle or changing the propeller pitch;
- (3) heading in the direction which the surface craft is to be directed.

Repetition of such procedures has the same meaning.

(ii) The following procedure performed by an aircraft means that the assistance of the surface craft to which the signal is directed is no longer required:

- crossing the wake of the surface craft close astern at a low altitude, opening and closing the throttle or changing the propeller pitch.

Note: Advance notification of changes in these signals will be given by the Organization as necessary.

Regulation 17. Pilot Ladders and Mechanical Pilot Hoists

Ships engaged on voyages in the course of which pilots are likely to be employed shall comply with the following requirements:

(a) *Pilot ladders*

- (i) The ladder shall be efficient for the purpose of enabling pilots to embark and disembark safely, kept clean and in good order and may be used by officials and other persons while a ship is arriving at or leaving a port.
- (ii) The ladder shall be secured in a position so that it is clear from any possible discharges from the ship, that each step rests firmly against the ship's side, that it is clear so far as is practicable of the finer lines of the ship and that the pilot can gain safe and convenient access to the ship after climbing not less than 1.5 metres (5 feet) and not more than 9 metres (30 feet). A single length of ladder shall be used capable of reaching the water from the point of access to the ship; in providing for this due allowance shall be made for all conditions of loading and trim of the ship and for an adverse list of 15 degrees. Whenever the distance from sea level to the point of access to the ship is more than 9 metres (30 feet), access from the pilot ladder to the ship shall be by means of an accommodation ladder or other equally safe and convenient means.
- (iii) The steps of the pilot ladder shall be:
 - (1) of hardwood, or other material of equivalent properties, made in one piece free of knots, having an efficient non-slip surface; the four lowest steps may be made of rubber of sufficient strength and stiffness or of other suitable material of equivalent characteristics;
 - (2) not less than 480 millimetres (19 inches) long, 115 millimetres (4 1/2 inches) wide, and 25 millimetres (1 inch) in depth, excluding any non-slip device;
 - (3) equally spaced not less than 300 millimetres (12 inches) nor more than 380 millimetres (15 inches) apart and be secured in such a manner that they will remain horizontal.
- (iv) No pilot ladder shall have more than two replacement steps which are secured in position by a method different from that used in the original construction of the ladder and any steps so secured shall be replaced as soon as reasonably practicable by steps secured in position by the method used in the original construction of the ladder. When any replacement step is secured to the side ropes of the ladder by means of grooves in the sides of the step, such grooves shall be in the longer sides of the step.
- (v) The side ropes of the ladder shall consist of two uncovered manila ropes not less than 60 millimetres (2 1/4 inches) in circumference on each side. Each rope shall be continuous with no joints below the top step. Two man-ropes properly secured to the ship and not less than 65 millimetres (2 1/2 inches) in circumference and a safety line shall be kept at hand ready for use if required.
- (vi) Battens made of hardwood, or other material of equivalent properties, in one piece and not less than 1.80 metres (5 feet 10 inches) long shall be provided at such intervals as will prevent the pilot ladder from twisting. The lowest batten shall be on the fifth step from the bottom of the ladder and the interval between any batten and the next shall not exceed 9 steps.

- (vii) Means shall be provided to ensure safe and convenient passage on to or into and off the ship between the head of the pilot ladder or of any accommodation ladder or other appliance provided. Where such passage is by means of a gateway in the rails or bulwark, adequate handholds shall be provided. Where such passage is by means of a bulwark ladder, such ladder shall be securely attached to the bulwark rail or platform and two handhold stanchions shall be fitted at the point of boarding or leaving the ship not less than 0.70 metre (2 feet 3 inches) nor more than 0.80 metre (2 feet 7 inches) apart. Each stanchion shall be rigidly secured to the ship's structure at or near its base and also at a higher point, shall be not less than 40 millimetres (1 1/2 inches) in diameter and shall extend not less than 1.20 metres (3 feet 11 inches) above the top of the bulwark.
 - (viii) Lighting shall be provided at night such that both the pilot ladder overside and also the position where the pilot boards the ship shall be adequately lit. A lifebuoy equipped with a self-igniting light shall be kept at hand ready for use. A heaving line shall be kept at hand ready for use if required.
 - (ix) Means shall be provided to enable the pilot ladder to be used on either side of the ship.
 - (x) The rigging of the ladder and the embarkation and disembarkation of a pilot shall be supervised by a responsible officer of the ship.
 - (xi) Where on any ship constructional features such as rubbing bands would prevent the implementation of any of these provisions, special arrangements shall be made to the satisfaction of the Administration to ensure that persons are able to embark and disembark safely.
- (b) *Mechanical pilot hoists*
- (i) A mechanical pilot hoist, if provided, and its ancillary equipment shall be of a type approved by the Administration. It shall be of such design and construction as to ensure that the pilot can be embarked and disembarked in a safe manner including a safe access from the hoist to the deck and *vice versa*.
 - (ii) A pilot ladder complying with the provisions of paragraph (a) of this Regulation shall be kept on deck adjacent to the hoist and available for immediate use.

Regulation 18. VHF Radiotelephone Stations

When a Contracting Government requires ships navigating in an area under its sovereignty to be provided with a Very High Frequency (VHF) radiotelephone station to be used in conjunction with a system which it has established in order to promote safety of navigation, such station shall comply with the provisions of Regulation 17 of Chapter IV and shall be operated in accordance with Regulation 8 of Chapter IV.

Regulation 19. Use of the Automatic Pilot

- (a) In areas of high traffic density, in conditions of restricted visibility and in all other hazardous navigational situations where the automatic pilot is used, it shall be possible to establish human control of the ship's steering immediately.
- (b) In circumstances as above, it shall be possible for the officer of the watch to have available without delay the services of a qualified helmsman who shall be ready at all times to take over steering control.

- (c) The change-over from automatic to manual steering and *vice versa* shall be made by or under the supervision of a responsible officer.

Regulation 20. Nautical Publications

All ships shall carry adequate and up-to-date charts, sailing directions, lists of lights, notices to mariners, tide tables and all other nautical publications necessary for the intended voyage.

Regulation 21. International Code of Signals

All ships which in accordance with the present Convention are required to carry a radiotelegraph or a radiotelephone installation shall carry the International Code of Signals. This publication shall also be carried by any other ship which in the opinion of the Administration has a need to use it.

CHAPTER VI CARRIAGE OF GRAIN

PART A GENERAL PROVISIONS

Regulation 1. Application

Unless expressly provided otherwise, this Chapter, including Parts A, B and C, applies to the carriage of grain in all ships to which the present Regulations apply.

Regulation 2. Definitions

- (a) The term "grain" includes wheat, maize (corn), oats, rye, barley, rice, pulses, seeds and processed forms thereof, whose behaviour is similar to that of grain in its natural state.
- (b) The term "filled compartment" refers to any compartment in which, after loading and trimming as required under Regulation 3, the bulk grain is at its highest possible level.
- (c) The term "partly filled compartment" refers to any compartment wherein bulk grain is not loaded in the manner prescribed in paragraph (b) of this Regulation.
- (d) The term "angle of flooding" (f) means an angle of heel at which openings in the hull, superstructures or deckhouses, which cannot be closed weathertight, immerse. In applying this definition, small openings through which progressive flooding cannot take place need not be considered as open.

Regulation 3. Trimming of Grain

All necessary and reasonable trimming shall be performed to level all free grain surfaces and to minimize the effect of grain shifting.

- (a) In any "filled compartment", the bulk grain shall be trimmed so as to fill all the spaces under the decks and hatch covers to the maximum extent possible.
- (b) After loading, all free grain surfaces in "partly filled compartments" shall be level.
- (c) The Administration issuing the document of authorization may, under Regulation 9 of this Chapter, grant dispensation from trimming in those cases where the underdeck void geometry resulting from free flowing grain into a compartment, which may be provided with feeding ducts, perforated decks or other similar means, is taken into account to its satisfaction when calculating the void depths.

Regulation 4. Intact Stability Requirements

- (a) The calculations required by this Regulation shall be based upon the stability information provided in accordance with Regulation 19 of Chapter II-I, of the present Convention, or with the requirements of the Administration issuing the document of authorization under Regulation 10 of this Chapter.

- (b) The intact stability characteristics of any ship carrying bulk grain shall be shown to meet, throughout the voyage, at least the following criteria after taking into account in the manner described in Part B, the heeling moments due to grain shift:
- (i) the angle of heel due to the shift of grain shall be not greater than 12 degrees except that an Administration giving authorization in accordance with Regulation 10 of this Chapter may require a lesser angle of heel if it considers that experience shows this to be necessary;
 - (ii) in the statical stability diagram, the net or residual area between the heeling arm curve and the righting arm curve up to the angle of heel of maximum difference between the ordinates of the two curves, or 40 degrees or the "angle of flooding" (θ), whichever is the least, shall in all conditions of loading be not less than 0.075 metre-radians; and
 - (iii) the initial metacentric height, after correction for the free surface effects of liquids in tanks, shall be not less than 0.30 metre.
- (c) Before loading bulk grain the master shall, if so required by the Contracting Government of the country of the port of loading, demonstrate the ability of the ship at all stages of any voyage to comply with the stability criteria required by paragraph (b) of this Regulation using the information approved and issued under Regulations 10 and 11 of this Chapter,
- (d) After loading, the master shall ensure that the ship shall be upright before proceeding to sea.

Regulation 5. Longitudinal Divisions and Saucers

- (a) In both "filled compartments" and "partly filled compartments", longitudinal divisions may be provided as a device either to reduce the adverse heeling effect of grain shift or to limit the depth of cargo used for securing the grain surface. Such divisions shall be fitted grain-tight and constructed in accordance with the provisions of Section I of Part C of this Chapter
- (b) In a "filled compartment", a division, if fitted to reduce the adverse effects of grain shift, shall:
- (i) in a tween-deck compartment extend from deck to deck; and
 - (ii) in a hold extend downwards from the underside of the deck or hatch covers as described in Section II of Part B of this Chapter.

Except in the case of linseed and other seeds having similar properties, a longitudinal division beneath a hatchway may be replaced by a saucer formed in the manner described in Section I of Part C of this Chapter.

- (c) In a "partly filled compartment", a division, if fitted, shall extend from one-eighth of the maximum breadth of the compartment above the level of the grain surface and to the same distance below the grain surface. When used to limit the depth of overstowing, the height of the centreline division shall be at least 0.6 metre above the level grain surface.
- (d) Furthermore, the adverse heeling effects of grain shift may be reduced by tightly stowing the wings and ends of a compartment with bagged grain or other suitable cargo adequately restrained from shifting.

Regulation 6. Securing

- (a) Unless account is taken of the adverse heeling effect due to grain shift in accordance with these Regulations, the surface of the bulk grain in any "partly filled compartment" shall be level and topped off with bagged grain tightly stowed and extending to a height of not less than one-sixteenth of the maximum breadth of the free grain surface or 1.2 metres, whichever is the greater. Instead of bagged grain, other suitable cargo exerting at least the same pressure may be used.
- (b) The bagged grain or such other suitable cargo shall be supported in the manner described in Section II of Part C of this Chapter. Alternatively, the bulk grain surface may be secured by strapping or lashing as described in that Section.

Regulation 7. Feeders and Trunks

If feeders or trunks are fitted, proper account shall be taken of the effects thereof when calculating the heeling moments as described in Section III of Part B of this Chapter. The strength of the divisions forming the boundaries of such feeders shall conform with the provisions of Section I of Part C of this Chapter.

Regulation 8. Combination Arrangements

Lower holds and tween-deck spaces in way thereof may be loaded as one compartment provided that, in calculating transverse heeling moments, proper account is taken of the flow of grain into the lower spaces.

Regulation 9. Application of Parts B and C

An Administration or a Contracting Government on behalf of an Administration may authorize departure from the assumptions contained in Parts B and C of this Chapter in those cases where it considers this to be justified having regard to the provisions for loading or the structural arrangements, provided the stability criteria in paragraph (b) of Regulation 4 of this Chapter are met. Where such authorization is granted under this Regulation, particulars shall be included in the document of authorization or grain loading data.

Regulation 10. Authorization

- (a) A document of authorization shall be issued for every ship loaded in accordance with the Regulations of this Chapter either by the Administration or an organization recognized by it or by a Contracting Government on behalf of the Administration. It shall be accepted as evidence that the ship is capable of complying with the requirements of these Regulations.
- (b) The document shall accompany and refer to the grain loading stability booklet provided to enable the master to meet the requirements of paragraph (c) of Regulation 4 of this Chapter. This booklet shall meet the requirements of Regulation 11 of this Chapter.
- (c) Such a document, grain loading stability data and associated plans may be drawn up in the official language or languages of the issuing country. If the language used is neither English nor French, the text shall include a translation into one of these languages.
- (d) A copy of such a document, grain loading stability data and associated plans shall be placed on board in order that the master, if so required, shall produce them for the inspection of the Contracting Government of the country of the port of loading.

- (e) A ship without such a document of authorization shall not load grain until the master demonstrates to the satisfaction of the Administration or the Contracting Government of the port of loading on behalf of the Administration that the ship in its proposed loaded condition will comply with the requirements of these Regulations.

Regulation 11. Grain Loading Information

This information shall be sufficient to allow the master to determine in all reasonable loading conditions the heeling moments due to grain shift calculated in accordance with Part B of this Chapter. It shall include the following:

- (a) Information which shall be approved by the Administration or by a Contracting Government on behalf of the Administration:
- (i) curves or tables of grain heeling moments for every compartment, filled or partly filled, or combination thereof, including the effects of temporary fittings;
 - (ii) tables of maximum permissible heeling moments or other information sufficient to allow the master to demonstrate compliance with the requirements of paragraph (c) of Regulation 4 of this Chapter;
 - (iii) details of the scantlings of any temporary fittings and where applicable the provisions necessary to meet the requirements of Section I(E) of Part C of this Chapter;
 - (iv) typical loaded service departure and arrival conditions and where necessary, intermediate worst service conditions;
 - (v) a worked example for the guidance of the master;
 - (vi) loading instructions in the form of notes summarizing the requirements of this Chapter.
- (b) Information which shall be acceptable to the Administration or to a Contracting Government on behalf of the Administration:
- (i) ship's particulars;
 - (ii) lightship displacement and the vertical distance from the intersection of the moulded base line and midship section to the centre of gravity (KG);
 - (iii) table of free surface corrections;
 - (iv) capacities and centres of gravity.

Regulation 12. Equivalent

Where an equivalent accepted by the Administration in accordance with Regulation 5 of Chapter I of this Convention is applied, particulars shall be included in the document of authorization or grain loading data.

Regulation 13. Exemptions for Certain Voyages

The Administration, or a Contracting Government on behalf of the Administration may, if it considers that the sheltered nature and conditions of the voyage are such as to render the application of any of the requirements of Regulations 3 to 12 of this Chapter unreasonable or unnecessary, exempt from those particular requirements individual ships or classes of ships.

PART B CALCULATION OF ASSUMED HEELING MOMENTS

Section I: Description of the assumed voids and method of calculating intact stability

(A) General

- (a) For the purpose of calculating the adverse heeling moment due to a shift of cargo surface in ships carrying bulk grain it shall be assumed that:
- (i) In "filled compartments" which have been trimmed in accordance with Regulation 3 of this Chapter a void exists under all boundary surfaces having an inclination to the horizontal less than 30 degrees and that the void is parallel to the boundary surface having an average depth calculated according to the formula:

$$V_d = V_{d_1} + 0.75(d - 600)\text{mm}$$

Where:

V_d = Average void depth in mm;

V_{d_1} = Standard void depth from Table I below;

d = Actual girder depth in mm.

In no case shall V_d be assumed to be less than 100 mm.

TABLE I

<i>Distance from hatchend or hatchside to boundary of compartment (metres)</i>	<i>Standard void depth Vd_1 (mm)</i>
0.5	570
1.0	530
1.5	500
2.0	480
2.5	450
3.0	440
3.5	430
4.0	430
4.5	430
5.0	430
5.5	450
6.0	470
6.5	490
7.0	520
7.5	550
8.0	590

Notes on Table I:

For distances greater than 8.0 metres the standard void depth Vd_1 shall be linearly extrapolated at 80 mm increase for each 1.0 metre increase in distance. Where there is a difference in depth between the hatchside girder or its continuation and the hatchend beam the greater depth shall be used except that:

- (1) when the hatchside girder or its continuation is shallower than the hatchend beam the voids abreast the hatchway may be calculated using the lesser depth; and
 - (2) where the hatchend beam is shallower than the hatchside girder or its continuation the voids fore and aft of the hatchway inboard of the continuation of the hatchside girder may be calculated using the lesser depth;
 - (3) where there is a raised deck clear of a hatchway the average void depth measured from the underside of the raised deck shall be calculated using the standard void depth in association with a girder depth of the hatchend beam plus the height of the raised deck.
- (ii) In "filled compartments" which are not trimmed in accordance with Regulation 3 of this Chapter and where the boundary surface has an inclination to the horizontal which is less than 30 degrees, the cargo surface has an inclination of 30 degrees to the horizontal after loading.
- (iii) Within filled hatchways and in addition to any open void within the hatch cover there is a void of average depth of 150 mm measured down to the grain surface from the lowest part of the hatch cover or the top of the hatchside coaming, whichever is the lower.
- (b) The description of the pattern of grain surface behaviour to be assumed in "partly filled compartments" is shown in Section IV of this Part.

- (c) For the purpose of demonstrating compliance with the stability criteria in paragraph (b) of Regulation 4 of this Chapter (see Figure 1), the ship's stability calculations shall be normally based upon the assumption that the centre of gravity of cargo in a "filled compartment" is at the volumetric centre of the whole cargo space. In those cases where the Administration authorizes account to be taken of the effect of assumed underdeck voids on the vertical position of the centre of gravity of the cargo in "filled compartments" it will be necessary to compensate for the adverse effect of the vertical shift of grain surfaces by increasing the assumed heeling moment due to the transverse shift of grain as follows:

Total heeling moment = 1.06 x calculated transverse heeling moment.

In all cases the weight of cargo in a "filled compartment" shall be the volume of the whole cargo space divided by the stowage factor.

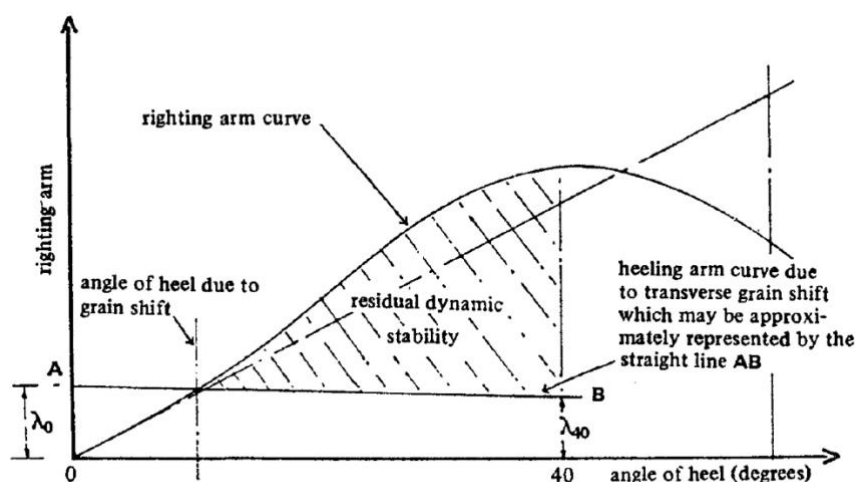

FIGURE 1

Notes on Figure 1.

- (1) Where:
- $$\lambda_0 = \frac{\text{Assumed Volumetric Heeling Moment due to Transverse Shift}}{\text{Stowage Factor} \times \text{Displacement}};$$
- $$\lambda_{40} = 0.8 \times \lambda_0;$$

Stowage factor = Volume per unit weight of grain cargo;

Displacement = Weight of ship, fuel, fresh water, stores etc. and cargo.

- (2) The righting arm curve shall be derived from cross-curves which are sufficient in number to accurately define the curve for the purpose of these requirements and shall include cross-curves at 12 degrees and 40 degrees.

- (d) In "partly filled compartments" the adverse effect of the vertical shift of grain surfaces shall be taken into account as follows:

Total heeling moment = 1.12 x calculated transverse heeling moment.

- (e) Any other equally effective method may be adopted to make the compensation required in paragraphs (c) and (d) above.

Section II: Assumed volumetric heeling moment of a filled compartment

(A) General

- (a) The pattern of grain surface movement relates to a transverse section across the portion of the compartment being considered and the resultant heeling moment should be multiplied by the length to obtain the total moment for that portion.
- (b) The assumed transverse heeling moment due to grain shifting is a consequence of final changes of shape and position of voids after grain has moved from the high side to the low side.
- (c) The resulting grain surface after shifting shall be assumed to be at 15 degrees to the horizontal.
- (d) In calculating the maximum void area that can be formed against a longitudinal structural member, the effects of any horizontal surfaces, e.g. flanges or face bars, shall be ignored.
- (e) The total areas of the initial and final voids shall be equal.
- (f) A discontinuous longitudinal division shall be considered effective over its full length.

(B) Assumptions

In the following paragraphs it is assumed that the total heeling moment for a compartment is obtained by adding the results of separate considerations of the following portions:

(a) Before and abaft hatchways:

- (i) If a compartment has two or more main hatchways through which loading may take place the depth of the underdeck void for the portion(s) between such hatchways shall be determined using the fore and aft distance to the midpoint between the hatchways.
- (ii) After the assumed shift of grain the final void pattern shall be as shown in Figure 2 below:

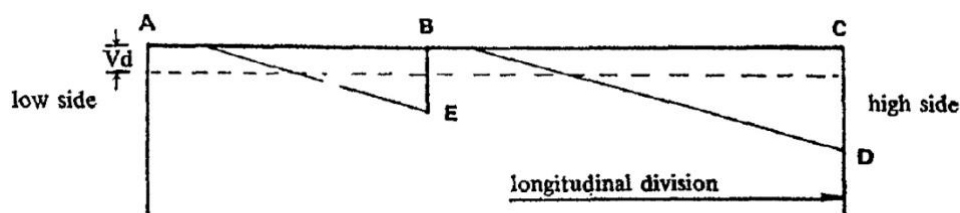

FIGURE 2

Notes on Figure 2.

- (1) If the maximum void area which can be formed against the girder at B is less than the initial area of the void under AB, i.e. $AB \times V_d$, the excess area shall be assumed to transfer to the final void on the high side.
 - (2) If the longitudinal division at C is one which has been provided in accordance with sub-paragraph (b)(ii) of Regulation 5 of this Chapter it shall extend to at least 0.6 metre below D or E whichever gives the greater depth.
- (b) *In and abreast hatchways:* After the assumed shift of grain the final void pattern shall be as shown in the following Figure 3 or Figure 4.

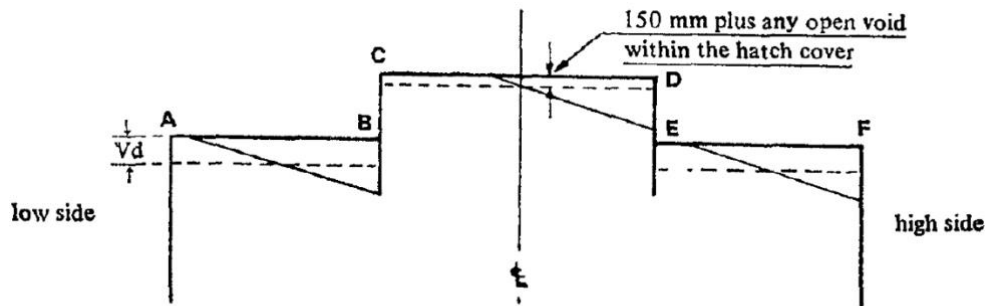

FIGURE 3

Notes on Figure 3.

- (1) AB: Any area in excess of that which can be formed against the girder at B shall transfer to the final void area in the hatchway.
- (2) CD: any area in excess of that which can be formed against the girder at E shall transfer to the final void area on the high side.

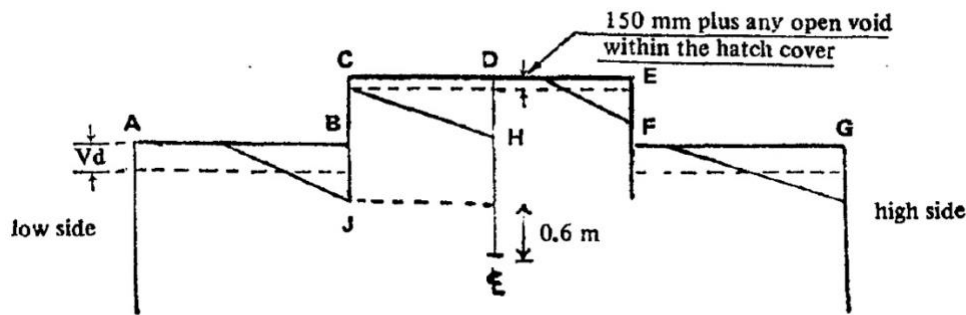

FIGURE 4

Notes on Figure 4.

- (1) If the centreline division is one which has been provided in accordance with sub-paragraph (b)(ii) of Regulation 5 of this Chapter it shall extend to at least 0.6 metre below H or J, whichever gives the greater depth.
- (2) The excess void area from AB shall transfer to the low side half of the hatchway in which two separate final void areas will be formed, viz., one against the centreline division and the other against the hatchside coaming and girder on the high side.
- (3) If a bagged saucer or bulk bundle is formed in a hatchway it shall be assumed, for the purpose of calculating transverse heeling moment, that such a device is at least equivalent to the centreline distribution.

(C) Compartments Loaded in Combination

The following paragraphs describe the pattern of void behaviour which shall be assumed when compartments are loaded in combination:

(a) Without effective centreline divisions.

- (i) under the upper deck, as for the single deck arrangement described in Section II(B) of this Part.
- (ii) Under the second deck, the area of void available for transfer from the low side, i.e. original void area less area against the hatchside girder, shall be assumed to transfer as follows: one half to the upper deck hatchway and one quarter each to the high side under the upper and second deck.

- (iii) Under the third and lower decks - the void areas available for transfer from the low side of each of these decks shall be assumed to transfer in equal quantities to all the voids under the decks on the high side and the void in the upper deck hatchway.
- (b) *With effective centreline divisions which extend into the upper deck hatchway.*
- (i) At all deck levels abreast the division the void areas available for transfer from the low side shall be assumed to transfer to the void under the low side half of the upper deck hatchway.
- (ii) At the deck level immediately below the bottom of the division the void area available for transfer from the low side shall be assumed to transfer as follows: one half to the void under the low side half of the upper deck hatchway and the remainder in equal quantities to the voids under the decks on the high side.
- (iii) At deck levels lower than those described in sub-paragraphs (i) and (ii) of this paragraph the void area available for transfer from the low side of each of those decks shall be assumed to transfer in equal quantities to the voids in each of the two halves of the upper deck hatchway on each side of the division and the voids under the decks on the high side.
- (c) *With effective centreline divisions which do not extend into the upper deck hatchway:*

Since no horizontal transfer of voids may be assumed to take place at the same deck level as the division the void area available for transfer from the low side at this level shall be assumed to transfer above the division to voids on the high sides in accordance with the principles of paragraphs (a) and (b) above.

Section III: Assumed volumetric heeling moment of feeders and trunks

(A) *Suitably Placed Wing Feeders (See Figure 5)*

It may be assumed that under the influence of ship motion underdeck voids will be substantially filled by the flow of grain from a pair of longitudinal feeders provided that:

- (a) The feeders extend for the full length of the deck and that the perforations therein are adequately spaced;
- (b) the volume of each feeder is equal to the volume of the underdeck void outboard of the hatchside girder and its continuation.

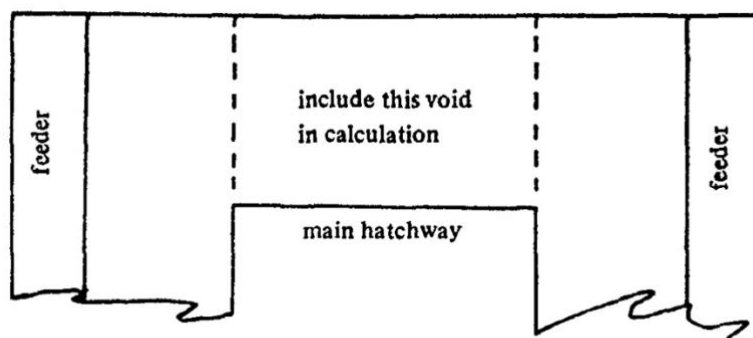

FIGURE 5

(B) Trunks Situated Over Main Hatchways

After the assumed shift of grain the final void pattern shall be as shown in Figure 6.

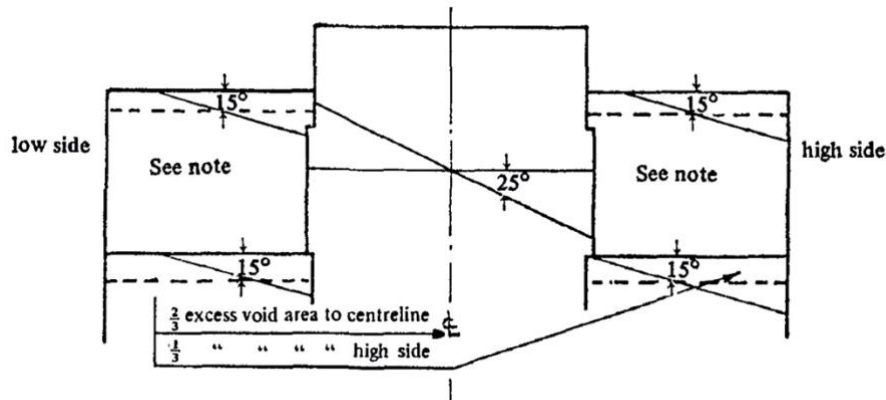

FIGURE 6

Notes on Figure 6. If the wing spaces in way of the trunk cannot be properly trimmed in accordance with Regulation 3 of this Chapter it shall be assumed that a 25 degree surface shift takes place.

Section IV: Assumed volumetric heeling moment of partly filled compartments

(A) General

When the free surface of the bulk grain has not been secured in accordance with Regulation 6 of this Chapter it shall be assumed that the grain surface after shifting shall be at 25 degrees to the horizontal.

(B) Discontinuous Longitudinal Divisions

In a compartment in which the longitudinal divisions are not continuous between the transverse boundaries, the length over which any such divisions are effective as devices to prevent full width shifts of grain surfaces shall be taken to be the actual length of the portion of the division under consideration less two-sevenths of the greater of the transverse distances between the division and its adjacent division or ship's side.

This correction does not apply in the lower compartments of any combination loading in which the upper compartment is either a "filled compartment" or a "partly filled compartment".

Section V: Alternative loading arrangements for existing ships

(A) General

A ship loaded in accordance with either Sub-Section (B) or Sub-Section (C) below shall be considered to have intact stability characteristics at least equivalent to the requirements of paragraph (b) of Regulation 4 of this Chapter. Documents of authorization permitting such loadings shall be accepted under the provisions of paragraph (e) of Regulation 10 of this Chapter.

For the purpose of this Part, the term "Existing Ship" means a ship, the keel of which is laid before the date of coming into force of this Chapter.

(B) Stowage of Specially Suitable Ships

- (a) Notwithstanding anything contained in Part B of this Chapter, bulk grain may be carried without regard to the requirements specified therein in ships which are constructed with two or more vertical or sloping grain-tight longitudinal divisions suitably disposed to limit the effect of any transverse shift of grain under the following conditions:
- (i) as many holds and compartments as possible shall be full and trimmed full;
 - (ii) for any specified arrangement of stowage the ship will not list to an angle greater than 5 degrees at any stage of the voyage where:
 - (1) in holds or compartments which have been trimmed full the grain surface settled 2 per cent by volume from the original surface and shifts to an angle of 12 degrees with that surface under all boundaries of these holds and compartments which have an inclination of less than 30 degrees to the horizontal;
 - (2) in "partly filled compartments or holds" free grain surfaces settle and shift as in sub-paragraph (ii)(1) of this paragraph or to such larger angle as may be deemed necessary by the Administration, or by a Contracting Government on behalf of the Administration, and grain surfaces if overstowed in accordance with Regulation 5 of this Chapter shift to an angle of 8 degrees with the original leveled surfaces. For the purpose of sub-paragraph (ii) of this paragraph shifting boards, if fitted, will be considered to limit the transverse shift of the surface of the grain;
 - (iii) the master is provided with a grain loading plan covering the stowage arrangements to be adopted and a stability booklet, both approved by the Administration, or by a Contracting Government on behalf of the Administration, showing the stability conditions upon which the calculations given in sub-paragraph (ii) of this paragraph are based.
- (b) The Administration, or a Contracting Government on behalf of the Administration, shall prescribe the precautions to be taken against shifting in all other conditions of loading of ships designed in accordance with paragraph (B)(a) of this Section which meet the requirements of sub-paragraphs (ii) and (iii) of that paragraph.

(C) Ships without Documents of Authorization

A ship not having on board documents of authorization issued in accordance with Regulations 4 and 10 of this Chapter may be permitted to load bulk grain under the requirements of Sub-Section (B) of this Section or provided that:

- (a) All "filled compartments" shall be fitted with centreline divisions extending for the full length of such compartments which extend downwards from the underside of the deck or hatch covers to a distance below the deck line of at least one-eighth of the maximum breadth of the compartment or 2.4 metres, whichever is the greater except that saucers constructed in accordance with Section II of Part C may be accepted in lieu of a centreline division in and beneath a hatchway except in the case of linseed and other seeds having similar properties.
- (b) All hatches to "filled compartments" shall be closed and covers secured in place.
- (c) All free grain surfaces in "partly filled compartments" shall be trimmed level and secured in accordance with Section II of Part C.

- (d) Throughout the voyage the metacentric height after correction for the free surface effects of liquids in tanks shall be 0.3 metre or that given by the following formula, whichever is the greater:

$$GM_R = \frac{L B V d (0.25 B - 0.645 \sqrt{V d B})}{SF \times \Delta \times 0.0875}$$

Where:

- L = total combined length of all full compartments;
B = moulded breadth of vessel;
SF = stowage factor;
Vd = calculated average void depth as per paragraph (a)(i) of Section I(A) of this Part;
 Δ = displacement.

PART C

GRAIN FITTINGS AND SECURING

Section I: Strength of grain fittings

- (A) General (including working stresses)
- (B) Divisions loaded on both sides
- (C) Divisions loaded on one side only
- (D) Saucers
- (E) Bundling of bulk
- (F) Securing hatch covers of filled compartments

Section II: Securing of partly filled compartments

- (A) Strapping or lashing
- (B) Overstowing arrangements
- (C) Bagged grain

Section I: Strength of grain fittings

(A) General

(a) Timber

All timber used for grain fittings shall be of good sound quality and of a type and grade which has been proved to be satisfactory for this purpose. The actual finished dimensions of the timber shall be in accordance with the dimensions hereinafter specified in this Part. Plywood of an exterior type bonded with waterproof glue and fitted so that the direction of the grain in the face plies is perpendicular to the supporting uprights or binder may be used provided that its strength is equivalent to that of solid timber of the appropriate scantlings.

(b) Working stresses

When calculating the dimensions of divisions loaded on one side, using the Tables in paragraphs (a) and (b) of Sub-Section (C) of this Section, the following working stresses should be adopted:

- For divisions of steel, 2000 kg per square cm
- For divisions of wood, 160 kg per square cm

(c) *Other materials*

Materials other than wood or steel may be approved for such divisions provided that proper regard has been paid to their mechanical properties.

(d) *Uprights*

- (i) Unless means are provided to prevent the end of uprights being dislodged from their sockets, the depth of housing at each end of each upright shall be not less than 75 mm. If an upright is not secured at the top, the uppermost shore or stay shall be fitted as near thereto as is practicable.
- (ii) The arrangements provided for inserting shifting boards by removing a part of the cross-section of an upright shall be such that the local level of stresses is not unduly high.
- (iii) The maximum bending moment imposed upon an upright supporting a division loaded on one side shall normally be calculated assuming that the ends of the uprights are freely supported. However, if an Administration is satisfied that any degree of fixity assumed will be achieved in practice, account may be taken of any reduction in the maximum bending moment arising from any degree of fixity provided at the ends of the upright.

(e) *Composite section*

Where uprights, binders or any other strength members are formed by two separate sections, one fitted on each side of a division and inter-connected by through bolts at adequate spacing, the effective section modulus shall be taken as the sum of the two moduli of the separate sections.

(f) *Partial division*

Where divisions do not extend to the full depth of the hold such divisions and their uprights shall be supported or stayed so as to be as efficient as those which do extend to the full depth of the hold.

(B) *Divisions Loaded on Both Sides*(a) *Shifting boards*

- (i) Shifting boards shall have a thickness of not less than 50 mm and shall be fitted grain-tight and where necessary supported by uprights.
- (ii) The maximum unsupported span for shifting boards of various thicknesses shall be as follows:

<i>Thickness</i>	<i>Maximum Unsupported Span</i>
50 mm	2.5
60 mm	3.0
70 mm	3.5
80 mm	4.0

If thicknesses greater than these are provided the maximum unsupported span will vary directly with the increase in thickness.

- (iii) The ends of all shifting boards shall be securely housed with 75 mm minimum bearing length.

(b) *Other materials*

Divisions formed by using materials other than wood shall have a strength equivalent to the shifting boards required in paragraph (a) of this Sub-Section.

(c) *Uprights*

- (i) Steel uprights used to support divisions loaded on both sides shall have a section modulus given by

$$W = a \times W_1$$

Where:

W = section modulus in cm³;

a = horizontal span between uprights in metres.

The section modulus per metre span W_1 shall be not less than that given by the formula:

$$W_1 = 14.8(h_1 - 1.2) \text{ cm}^3 \text{ per metre,}$$

Where:

h_1 is the vertical unsupported span in metres and shall be taken as the maximum value of the distance between any two adjacent stays or between the stay or either end of the upright. Where this distance is less than 2.4 metres the respective modulus shall be calculated as if the actual value was 2.4 metres.

- (ii) The moduli of wood uprights shall be determined by multiplying by 12.5 the corresponding moduli for steel uprights. If other materials are used their moduli shall be at least that required for steel increased in proportion to the ratio of the permissible stresses for steel to that of the material used. In such cases attention shall be paid also to the relative rigidity of each upright to ensure that the deflection is not excessive.
- (iii) The horizontal distance between uprights shall be such that the unsupported spans of the shifting boards do not exceed the maximum span specified in sub-paragraph (ii) of paragraph (a) of this Sub-Section.

(d) *Shores*

- (i) Wood shores, when used, shall be in a single piece and shall be securely fixed at each end and heeled against the permanent structure of the ship except that they shall not bear directly against the side plating of the ship.
- (ii) Subject to the provisions of sub-paragraphs (iii) and (iv) below, the minimum size of wood shores shall be as follows:

<i>Length of shore in metres</i>	<i>Rectangular section (mm)</i>	<i>Diameter of circular section (mm)</i>
Not exceeding 3m	150x100	140
Over 3 m but not exceeding 5 m	150x150	165
Over 5 m but not exceeding 6 m	150x150	180
Over 6 m but not exceeding 7 m	200x150	190
Over 7 m but not exceeding 8 m	200x150	200
Exceeding 8 m	200x150	215

Shores of 7 metres or more in length shall be securely bridged at approximately mid-length.

- (iii) When the horizontal distance between the uprights differs significantly from 4 metres, the moments of inertia of the shores may be changed in direct proportion.
- (iv) Where the angle of the shore to the horizontal exceeds 10 degrees the next larger shore to that required by sub-paragraph (ii) of this paragraph shall be fitted provided that in no case shall the angle between any shore and the horizontal exceed 45 degrees.

(e) *Stays*

Where stays are used to support divisions loaded on both sides, they shall be fitted horizontally or as near thereto as practicable, well secured at each end and formed of steel wire rope. The sizes of the wire rope shall be determined assuming that the divisions and upright which the stay supports are uniformly loaded at 500 kg/m². The working load so assumed in the stay shall not exceed one-third of its breaking load.

(C) *Divisions Loaded on One Side Only*

(a) *Longitudinal divisions*

The load in kg per metre length of the division shall be taken to be as follows:

TABLE P²⁹
B (m)

<i>h</i> (m)	2	3	4	5	6	7	8	10
1.5	850	900	1010	1225	1500	1770	2060	2645
2.0	1390	1505	1710	1985	2295	2605	2930	3590
2.5	1985	2160	2430	2740	3090	3435	3800	4535
3.0	2615	2845	3150	3500	3885	4270	4670	5480
3.5	3245	3525	3870	4255	4680	5100	5540	6425
4.0	3890	4210	4590	5015	5475	5935	6410	7370
4.5	4535	4890	5310	5770	6270	6765	7280	8315
5.0	5185	5570	6030	6530	7065	7600	8150	9260
6.0	6475	6935	7470	8045	8655	9265	9890	11150
7.0	7765	8300	8910	9560	10245	10930	11630	13040
8.0	9055	9665	10350	11075	11835	12595	13370	14930
9.0	10345	11030	11790	12590	13425	14260	15110	16820
10.0	11635	12395	13230	14105	15015	15925	16850	18710

h = height of grain in metres from the bottom of the division³⁰

B = transverse extent of the bulk grain in metres

²⁹ For the purpose of converting the above loads into British units (ton/ft) 1 kg per metre length shall be taken to be equivalent to 0.0003 ton per foot length.

³⁰ Where the distance from a division to a feeder or hatchway is 1 metre or less, the height - *h* - shall be taken to the level of the grain within that hatchway or feeder. In all other cases the height shall be taken to the overhead deck in way of the division.

For other values of h or B the loads shall be determined by linear interpolation or extrapolation as necessary.

(b) *Transverse divisions*

The load in kg per metre length of the division shall be taken to be as follows:

TABLE II³¹

L (m)

h (m)	2	3	4	5	6	7	8	10	12	14	16
1.5	670	690	730	780	835	890	935	1000	1040	1050	1050
2.0	1040	1100	1170	1245	1325	1400	1470	1575	1640	1660	1660
2.5	1460	1565	1675	1780	1880	1980	2075	2210	2285	2305	2305
3.0	1925	2065	2205	2340	2470	2590	2695	2845	2925	2950	2950
3.5	2425	2605	2770	2930	3075	3205	3320	3480	3570	3595	3595
4.0	2950	3160	3355	3535	3690	3830	3950	4120	4210	4235	4240
4.5	3495	3725	3940	4130	4295	4440	4565	4750	4850	4880	4885
5.0	4050	4305	4535	4735	4910	5060	5190	5385	5490	5525	5530
6.0	5175	5465	5720	5945	6135	6300	6445	6655	6775	6815	6825
7.0	6300	6620	6905	7150	7365	7445	7700	7930	8055	8105	8115
8.0	7425	7780	8090	8360	8590	8685	8950	9200	9340	9395	9410
9.0	8550	8935	9275	9565	9820	9930	10205	10475	10620	10685	10705
10.0	9680	10095	10460	10770	11045	11270	11460	11745	11905	11975	11997

h = height of grain in metres from the bottom of the division³²

L = longitudinal extent of the bulk grain in metres

For other values of h or L the loads shall be determined by linear interpolation or extrapolation as necessary.

(c) *Vertical distribution of the loads*

The total load per unit length of divisions shown in the Tables I and II above may, if considered necessary, be assumed to have a trapezoidal distribution with height. In such cases, the reaction loads at the upper and lower ends of a vertical member or upright are not equal. The reaction loads at the upper end expressed as percentages of the total load supported by the vertical member or upright shall be taken to be those shown in Tables III and IV below.

³¹ For the purpose of converting the above loads in British units (ton/ft) 1 kg per metre length shall be taken to be equivalent to 0.0003 ton per foot length.

³² Where the distance from a division to a feeder or hatchway is 1 metre or less, the height - h - shall be taken to the level of the grain within that hatchway or feeder. In all other cases the height shall be taken to the overhead deck in way of the division.

TABLE III
LONGITUDINAL DIVISIONS LOADED ON ONE SIDE ONLY

Bearing reaction at the upper end of upright as percentage of load (Table I)
B(m)

<i>h (m)</i>	2	3	4	5	6	7	8	10
1.5	43.3	45.1	45.9	46.2	46.2	46.2	46.2	46.2
2	44.5	46.7	47.6	47.8	47.8	47.8	47.8	47.8
2.5	45.4	47.6	48.6	48.8	48.8	48.8	48.8	48.8
3	46.0	48.3	49.2	49.4	49.4	49.4	49.4	49.4
3.5	46.5	48.8	49.7	49.8	49.8	49.8	49.8	49.8
4	47.0	49.1	49.9	50.1	50.1	50.1	50.1	50.1
4.5	47.4	49.4	50.1	50.2	50.2	50.2	50.2	50.2
5	47.7	49.4	50.1	50.2	50.2	50.2	50.2	50.2
6	47.9	49.5	50.1	50.2	50.2	50.2	50.2	50.2
7	47.9	49.5	50.1	50.2	50.2	50.2	50.2	50.2
8	47.9	49.5	50.1	50.2	50.2	50.2	50.2	50.2
9	47.9	49.5	50.1	50.2	50.2	50.2	50.2	50.2
10	47.9	49.5	50.1	50.2	50.2	50.2	50.2	50.2

B = transverse extent of the bulk grain in metres

For other values of h or B the reaction loads shall be determined by linear interpolation or extrapolation as necessary.

TABLE IV
TRANSVERSE DIVISIONS LOADED ON ONE SIDE ONLY

Bearing reaction at the upper end of upright as percentage of load (Table II)
L(m)

<i>h (m)</i>	2	3	4	5	6	7	8	10	12	14	16
1.5	37.3	38.7	39.7	40.6	41.4	42.1	42.6	43.6	44.3	44.8	45.0
2	39.6	40.6	41.4	42.1	42.7	43.1	43.6	44.3	44.7	45.0	45.2
2.5	41.0	41.8	42.5	43.0	43.5	43.8	44.2	44.7	45.0	45.2	45.2
3	42.1	42.8	43.3	43.8	44.2	44.5	44.7	45.0	45.2	45.3	45.3
3.5	42.9	43.5	43.9	44.3	44.6	44.8	45.0	45.2	45.3	45.3	45.3
4	43.5	44.0	44.4	44.7	44.9	45.0	45.2	45.4	45.4	45.4	45.4
5	43.9	44.3	44.6	44.8	45.0	45.2	45.3	45.5	45.5	45.5	45.5
6	44.2	44.5	44.8	45.0	45.2	45.3	45.4	45.6	45.6	45.6	45.6
7	44.3	44.6	44.9	45.1	45.3	45.4	45.5	45.6	45.6	45.6	45.6
8	44.3	44.6	44.9	45.1	45.3	45.4	45.5	45.6	45.6	45.6	45.6
9	44.3	44.6	44.9	45.1	45.3	45.4	45.5	45.6	45.6	45.6	45.6
10	44.3	44.6	44.9	45.1	45.3	45.4	45.5	45.6	45.6	45.6	45.6

L = longitudinal extent of the bulk grain in metres

For other values of h or L the reaction loads shall be determined by linear interpolation or extrapolation as necessary.

The strength of the end connexions of such vertical members or uprights may be calculated on the basis of the maximum load likely to be imposed at either end. These loads are as follows:

- Longitudinal Divisions
 - Maximum load at the top 50% of the appropriate total load from Table I
 - Maximum load at the bottom 55% of the appropriate total load from Table I
- Transverse Divisions
 - Maximum load at the top 45% of the appropriate total load from Table II
 - Maximum load at the bottom 60% of the appropriate total load from Table II

The thickness of horizontal wooden boards may also be determined having regard to the vertical distribution of the loading represented by Tables III and IV above and in such cases

$$t = 10a \sqrt{\frac{p \times k}{h \times 213.3}}$$

Where:

- t = thickness of board in mm;
- a = horizontal span of the board i.e. distance between uprights in metres;
- h = head of grain to the bottom of the division in metres;
- p = total load per unit length derived from Table I or II in kilogrammes;
- k = factor dependent upon vertical distribution of the loading.

When the vertical distribution of the loading is assumed to be uniform, i.e. rectangular, k shall be taken as equal to 1.0. For a trapezoidal distribution

$$k = 1.0 + 0.06 (50 - R)$$

Where:

- R is the upper end bearing reaction taken from Table III or IV.

(d) *Stays or shores*

The sizes of stays and shores shall be so determined that the loads derived from Tables I and II in the preceding paragraphs (a) and (b) shall not exceed one-third of the breaking loads.

(D) *Saucers*

When a saucer is used to reduce the heeling moments in a "filled compartment", its depth, measured from the bottom of the saucer to the deck line, shall be as follows:

- For ships with a moulded breadth of up to 9.1 metres, not less than 1.2 metres.
- For ships with a moulded breadth of 18.3 metres or more, not less than 1.8 metres.
- For ships with a moulded breadth between 9.1 metres and 18.3 metres, the minimum depth of the saucer shall be calculated by interpolation.

The top (mouth) of the saucer shall be formed by the underdeck structure in the way of the hatchway, i.e. hatchside girders or coamings and hatchend beams. The saucer and hatchway above shall be completely filled with bagged grain or other suitable cargo laid down on a separation cloth or its equivalent and stowed tightly against adjacent structures and the portable hatchway beams if the latter are in place.

(E) Bundling of Bulk

As an alternative to filling the saucer with bagged grain or other suitable cargo a bundle of bulk grain may be used provided that:

- (a) The saucer is lined with a material acceptable to the Administration having a tensile strength of not less than 274 kg per 5 cm strip and which is provided with suitable means for securing at the top.
- (b) As an alternative to paragraph (a) above a material acceptable to the Administration having a tensile strength of not less than 137 kg per 5 cm strip may be used if the saucer is constructed as follows:
 - Athwartship lashings acceptable to the Administration shall be placed inside the saucer formed in the bulk grain at intervals of not more than 2.4 metres. These lashing shall be of sufficient length to permit being drawn up tight and secured at the top of the saucer.
 - Dunnage not less than 25 mm in thickness or other suitable material of equal strength and between 150 to 300 mm in width shall be placed fore and aft over these lashings to prevent the cutting or chafing of the material which shall be placed thereon to line the saucer.
- (c) The saucer shall be filled with bulk grain and secured at the top except that when using material approved under paragraph (b) above further dunnage shall be laid on top after lapping the material before the saucer is secured by setting up the lashings.
- (d) If more than one sheet of material is used to line the saucer they shall be joined at the bottom either by sewing or a double lap,
- (e) The top of the saucer shall be coincidental with the bottom of the beams when these are in place and suitable general cargo or bulk grain may be placed between the beams on top of the saucer.

(F) Securing Hatch Covers of Filled Compartments

If there is no bulk grain or other cargo above a "filled compartment" the hatch covers shall be secured in an approved manner having regard to the weight and permanent arrangements provided for securing such covers.

The documents of authorization issued under Regulation 10 of this Chapter shall include reference to the manner of securing considered necessary by the Administration issuing such documents.

Section II: Securing of partly filled compartments

(A) Strapping or Lashing

- (a) When, in order to eliminate heeling moments in "partly filled compartments", strapping or lashing is utilized, the securing shall be accomplished as follows:
- (i) The grain shall be trimmed and levelled to the extent that it is very slightly crowned and covered with burlap separation cloths, tarpaulins or the equivalent.
 - (ii) The separation cloths and/or tarpaulins shall overlap at least 1.8 metres.
 - (iii) Two solid floors of rough 25 mm by 150 mm to 300 mm lumber shall be laid with the top floor running longitudinally and nailed to an athwartships bottom floor. Alternatively, one solid floor of 50 mm lumber, running longitudinally and nailed over the top of a 50 mm bottom bearer not less than 150 mm wide, may be used. The bottom bearers shall extend the full breadth of the compartment and shall be spaced not more than 2.4 metres apart. Arrangements utilizing other materials and deemed by an Administration to be equivalent to the foregoing may be accepted,
 - (iv) Steel wire rope (19 mm diameter or equivalent), doubled steel strapping (50 mm x 1.3 mm and having a breaking load of at least 5000 kg), or chain of equivalent strength, each of which shall be set tight by means of a 32 mm turnbuckle, may be used for lashings. A winch tightener, used in conjunction with a locking arm, may be substituted for the 32 mm turnbuckle when steel strapping is used, provided suitable wrenches are available for setting up as necessary. When steel strapping is used, not less than three crimp seals shall be used for securing the ends. When wire is used, not less than four clips shall be used for forming eyes in the lashings.
 - (v) Prior to the completion of loading the lashing shall be positively attached to the framing at a point approximately 450 mm below the anticipated final grain surface by means of either a 25 mm shackle or beam clamp of equivalent strength.
 - (vi) The lashings shall be spaced not more than 2.4 metres apart and each shall be supported by a bearer nailed over the top of the fore and aft floor. This bearer shall consist of not less than 25 mm by 150 mm lumber or its equivalent and shall extend the full breadth of the compartment.
 - (vii) During the voyage the strapping shall be regularly inspected and set up where necessary.

(B) Overstowing Arrangements

Where bagged grain or other suitable cargo is utilized for the purpose of securing "partly filled compartments", the free grain surface shall be covered with a separation cloth or equivalent or by a suitable platform. Such platforms shall consist of bearers spaced not more than 1.2 metres apart and 25 mm boards laid thereon spaced not more than 100 mm apart. Platforms may be constructed of other materials provided they are deemed by an Administration to be equivalent.

(C) Bagged Grain

Bagged grain shall be carried in sound bags which shall be well filled and securely closed.

CHAPTER VII CARRIAGE OF DANGEROUS GOODS

Regulation 1. Application

- (a) Unless expressly provided otherwise, this Chapter applies to the carriage of dangerous goods in all ships to which the present Regulations apply.
- (b) The provisions of this Chapter do not apply to ship's stores and equipment or to particular cargoes carried in ships specially built or converted as a whole for that purpose, such as tankers.
- (c) The carriage of dangerous goods is prohibited except in accordance with the provisions of this Chapter.
- (d) To supplement the provisions of this Chapter each Contracting Government shall issue, or cause to be issued, detailed instructions on the safe packing and stowage of specific dangerous goods or categories of dangerous goods which shall include any precautions necessary in their relation to other cargo.

Regulation 2. Classification

Dangerous goods shall be divided into the following classes:

- Class 1 - Explosives.
- Class 2 - Gases: compressed, liquefied or dissolved under pressure.
- Class 3 - Inflammable liquids.
- Class 4.1 - Inflammable solids.
- Class 4.2 - Inflammable solids, or substances, liable to spontaneous combustion.
- Class 4.3 - Inflammable solids, or substances, which in contact with water emit inflammable gases.
- Class 5.1 - Oxidizing substances.
- Class 5.2 - Organic peroxides.
- Class 6.1 - Poisonous (toxic) substances.
- Class 6.2 - Infectious substances.
- Class 7 - Radioactive substances.
- Class 8 - Corrosives.
- Class 9 - Miscellaneous dangerous substances, that is any other substance which experience has shown, or may show, to be of such a dangerous character that the provisions of this Chapter should apply to it.

Regulation 3. Packing

- (a) The packing of dangerous goods shall be:
 - (i) well made and in good condition;
 - (ii) of such a character that any interior surface with which the contents may come in contact is not dangerously affected by the substance being conveyed; and
 - (iii) capable of withstanding the ordinary risks of handling and carriage by sea.

- (b) Where the use of absorbent or cushioning material is customary in the packing of liquids in receptacles that material shall be:
 - (i) capable of minimizing the dangers to which the liquid may give rise;
 - (ii) so disposed as to prevent movement and ensure that the receptacle remains surrounded; and
 - (iii) where reasonably possible of sufficient quantity to absorb the liquid in the event of breakage of the receptacle.
- (c) Receptacles containing dangerous liquids shall have ullage at the filling temperature sufficient to allow for the highest temperature during the course of normal carriage.
- (d) Cylinders or receptacles for gases under pressure shall be adequately constructed, tested, maintained and correctly filled.
- (e) Empty receptacles which have been used previously for the carriage of dangerous goods shall themselves be treated as dangerous goods unless they have been cleaned and dried or, when the nature of the former contents permit with safety, have been closed securely.

Regulation 4. Marking and Labelling

Each receptacle containing dangerous goods shall be marked with the correct technical name (trade names shall not be used) and identified with a distinctive label or stencil of the label so as to make clear the dangerous character. Each receptacle shall be so labelled except receptacles containing chemicals packed in limited quantities and large shipments which can be stowed, handled and identified as a unit.

Regulation 5. Documents

- (a) In all documents relating to the carriage of dangerous goods by sea where the goods are named the correct technical name of the goods shall be used (trade names shall not be used) and the correct description given in accordance with the classification set out in Regulation 2 of this Chapter.
- (b) The shipping documents prepared by the shipper shall include, or be accompanied by, a certificate or declaration that the shipment offered for carriage is properly packed, marked and labelled and in proper condition for carriage.
- (c) Each ship carrying dangerous goods shall have a special list or manifest setting forth, in accordance with Regulation 2 of this Chapter, the dangerous goods on board and the location thereof. A detailed stowage plan which identifies by class and sets out the location of all dangerous goods on board may be used in place of such special list or manifest.

Regulation 6. Stowage Requirements

- (a) Dangerous goods shall be stowed safely and appropriately according to the nature of the goods. Incompatible goods shall be segregated from one another.
- (b) Explosives (except ammunition) which present a serious risk shall be stowed in a magazine which shall be kept securely closed while at sea. Such explosives shall be segregated from detonators. Electrical apparatus and cables in any compartment in which explosives are carried shall be designed and used so as to minimize the risk of fire or explosion.
- (c) Goods which give off dangerous vapours shall be stowed in a well ventilated space or on deck.
- (d) In ships carrying inflammable liquids or gases special precautions shall be taken where necessary against fire or explosion.
- (e) Substances which are liable to spontaneous heating or combustion shall not be carried unless adequate precautions have been taken to prevent the outbreak of fire.

Regulation 7. Explosives in Passenger Ships

- (a) In passenger ships the following explosives only may be carried:
- (i) safety cartridges and safety fuses;
 - (ii) small quantities of explosives not exceeding 9 kilogrammes (20 pounds) total net weight;
 - (iii) distress signals for use in ships or aircraft, if the total weight of such signals does not exceed 1,016 kilogrammes (2,240 pounds);
 - (iv) except in ships carrying unberthed passengers, fireworks which are unlikely to explode violently.
- (b) Notwithstanding the provisions of paragraph (a) of this Regulation additional quantities or types of explosives may be carried in passenger ships in which there are special safety measures approved by the Administration.

CHAPTER VIII NUCLEAR SHIPS

Regulation 1. Application

This Chapter applies to all nuclear ships except ships of war.

Regulation 2. Application of Other Chapters

The Regulations contained in the other Chapters of the present Convention apply to nuclear ships except as modified by this Chapter.

Regulation 3. Exemptions

A nuclear ship shall not, in any circumstances, be exempted from compliance with any Regulations of this Convention.

Regulation 4. Approval of reactor installation

The design, construction and standards of inspection and assembly of the reactor installation shall be subject to the approval and satisfaction of the Administration and shall take account of the limitations which will be imposed on surveys by the presence of radiation.

Regulation 5. Suitability of Reactor Installation for Service on Board Ship

The reactor installation shall be designed having regard to the special conditions of service on board ship both in normal and exceptional circumstances of navigation.

Regulation 6. Radiation Safety

The Administration shall take measures to ensure that there are no unreasonable radiation or other nuclear hazards, at sea or in port, to the crew, passengers or public, or to the waterways or food or water resources.

Regulation 7 Safety Assessment

- (a) A Safety Assessment shall be prepared to permit evaluation of the nuclear power plant and safety of the ship to ensure that there are no unreasonable radiation or other hazards, at sea or in port, to the crew, passengers or public, or to the waterways or food or water resources. The Administration, when satisfied, shall approve such Safety Assessment which shall always be kept up-to-date.
- (b) The Safety Assessment shall be made available sufficiently in advance to the Contracting Governments of the countries which a nuclear ship intends to visit so that they may evaluate the safety of the ship.

Regulation 8. Operating Manual

A fully detailed Operating Manual shall be prepared for the information and guidance of the operating personnel in their duties on all matters relating to the operation of the nuclear power plant and having an important bearing on safety. The Administration, when satisfied, shall approve such Operating Manual and a copy shall be kept on board the ship. The Operating Manual shall always be kept up-to-date.

Regulation 9. Surveys

Survey of nuclear ships shall include the applicable requirements of Regulation 7 of Chapter I, or of Regulations 8, 9 and 10 of Chapter I, except in so far as surveys are limited by the presence of radiation.

In addition, the surveys shall include any special requirements of the Safety Assessment. They shall in all cases, notwithstanding the provisions of Regulations 8 and 10 of Chapter I, be carried out not less frequently than once a year.

Regulation 10. Certificates

- (a) The provisions of paragraph (a) of Regulation 12 of Chapter I and of Regulation 14 of Chapter I shall not apply to nuclear ships.
- (b) A Certificate, called a Nuclear Passenger Ship Safety Certificate shall be issued after inspection and survey to a nuclear passenger ship which complies with the requirements of Chapters II-1, II-2, III, IV and VIII, and any other relevant requirements of the present Regulations.
- (c) A Certificate, called a Nuclear Cargo Ship Safety Certificate shall be issued after inspection and survey to a nuclear cargo ship which satisfies the requirements for cargo ships on survey set out in Regulation 10 of Chapter I, and complies with the requirements of Chapters II-1, II-2, III, IV and VIII and any other relevant requirements of the present Regulations.
- (d) Nuclear Passenger Ship Safety Certificates and Nuclear Cargo Ship Safety Certificates shall state: "That the ship, being a nuclear ship, complied with all requirements of Chapter VIII of the Convention and conformed to the Safety Assessment approved for the ship".
- (e) Nuclear Passenger Ship Safety Certificates and Nuclear Cargo Ship Safety Certificates shall be valid for a period of not more than 12 months.
- (f) Nuclear Passenger Ship Safety Certificates and Nuclear Cargo Ship Safety Certificates shall be issued either by the Administration or by any person or organization duly authorized by it. In every case, that Administration assumes full responsibility for the certificate.

Regulation 11. Special Control

In addition to the control established by Regulation 19 of Chapter I, nuclear ships shall be subject to special control before entering the ports and in the ports of Contracting Governments, directed towards verifying that there is on board a valid Nuclear Ship Safety Certificate and that there are no unreasonable radiation or other hazards at sea or in port, to the crew, passengers or public, or to the waterways or food or water resources.

Regulation 12. Casualties

In the event of any accident likely to lead to an environmental hazard the master of a nuclear ship shall immediately inform the Administration. The master shall also immediately inform the competent Governmental authority of the country in whose waters the ship may be, or whose waters the ship approaches in a damaged condition.